

CLEARWATER PROGRAM

Master Facilities Plan

FINAL

SCH# 2008101074
November 2012



SANITATION DISTRICTS OF LOS ANGELES COUNTY



CLEARWATER PROGRAM

Master Facilities Plan

FINAL

Prepared by:

**Sanitation Districts of Los Angeles County
Facilities Planning Department
1955 Workman Mill Road
Whittier, CA 90601
Contact: Steven Highter, P.E.
Supervising Engineer, Planning Section
(562) 908-4288 x2711**

With Assistance From:

**CH2M Hill
1000 Wilshire Boulevard, 21st Floor
Los Angeles, CA 90017**

**MWH
618 Michillinda Avenue, Suite 200
Arcadia, CA 91007**

State Clearinghouse Number: 2008101074

November 2012

Also Available at:

www.ClearwaterProgram.org

TABLE OF CONTENTS

Executive Summary..... Under Separate Cover

Chapter 1	Introduction.....	1-1
1.1	Background.....	1-1
1.2	Sanitation Districts of Los Angeles County	1-1
1.2.1	Mission Statement	1-2
1.3	Joint Outfall System.....	1-3
1.3.1	JOS Wastewater Treatment System.....	1-3
1.3.2	JOS Conveyance System	1-4
1.3.3	JOS Ocean Discharge System	1-4
1.3.4	JOS Planning History	1-5
1.4	Clearwater Program.....	1-8
1.4.1	Clearwater Program Objectives	1-8
1.4.2	Project Purpose and Needs	1-9
1.4.3	Clearwater Program Scope.....	1-10
1.4.4	Recommended Plan	1-11
1.4.5	Public Outreach Program.....	1-11
1.5	Master Facilities Plan Organization and Content.....	1-11
Chapter 2	Planning Area Characteristics	2-1
2.1	Physical Setting	2-1
2.1.1	Clearwater Program Planning Area	2-1
2.1.2	Communities Within the Planning Area	2-1
2.1.3	Climate	2-2
2.1.4	Geography and Topography	2-2
2.1.5	Geology.....	2-2
2.1.6	Hydrology	2-3
2.1.7	Air Quality	2-3
2.2	Demographics.....	2-4
2.2.1	Population	2-4
2.2.2	Housing.....	2-5
2.2.3	Income	2-6
2.2.4	Employment	2-7
Chapter 3	Laws and Regulations.....	3-1
3.1	Introduction	3-1
3.2	Regulations for Federal and State Waters.....	3-1
3.2.1	Federal Regulations	3-1
3.2.2	State Regulations.....	3-4
3.2.3	Local Regulations	3-5
3.3	Discharge Regulations for JOS Plants	3-6
3.3.1	WRP Requirements	3-7

	3.3.2	JWPCP Requirements	3-12
3.4		Regulations for Drinking Water	3-17
	3.4.1	Federal Regulations	3-17
	3.4.2	State Regulations	3-18
3.5		Regulations for Water Reuse	3-18
	3.5.1	State Regulations	3-18
	3.5.2	Local Regulations	3-24
3.6		Regulations for Wet Weather Flow Management	3-24
	3.6.1	Federal Regulations	3-24
	3.6.2	State Regulations	3-25
3.7		Regulations for Air Quality	3-25
	3.7.1	Federal Regulations	3-26
	3.7.2	State Regulations	3-28
	3.7.3	Local Regulations	3-31
3.8		Regulations for Biosolids Management	3-31
	3.8.1	Federal Regulations	3-31
	3.8.2	State Regulations	3-32
3.9		Regulations for Hazardous Materials	3-32
	3.9.1	Federal Regulations	3-32
	3.9.2	State Regulations	3-33
3.10		Regulations for Environmental Impacts	3-34
	3.10.1	Federal Regulations	3-34
	3.10.2	State Regulations	3-35
3.11		Regulations for Endangered Species	3-35
	3.11.1	Federal Regulations	3-35
	3.11.2	State Regulations	3-36
	3.11.3	Local Regulations	3-37
3.12		Regulations for Cultural Resources	3-37
	3.12.1	Federal Regulations	3-37
	3.12.2	State Regulations	3-38
3.13		Other Agencies Associated With Tunneling and Marine Construction	3-38
	3.13.1	Federal Agencies	3-38
	3.13.2	State Agencies	3-38
3.14		Other Applicable Laws and Regulations	3-39
	3.14.1	Federal Regulations	3-39
	3.14.2	State Regulations	3-40
	3.14.3	Local Regulations	3-40
Chapter 4		Water, Wastewater, and Projections	4-1
	4.1	Introduction	4-1
	4.2	Water Use	4-1
		4.2.1 Historical Water Use	4-1
		4.2.2 Significance to Clearwater Program Facilities Planning	4-1
	4.3	Existing Water Supply	4-2
		4.3.1 Imported Water	4-2
		4.3.2 Local Surface Water	4-4
		4.3.3 Groundwater	4-4
		4.3.4 Recycled Water	4-4

4.4	Projected Water Demand	4-5
4.4.1	Municipal Water Demand.....	4-5
4.4.2	Other Water Demand.....	4-5
4.4.3	Water Conservation	4-6
4.5	Future Water Demand and Supply Balance	4-6
4.6	Uncertainties and Possible Effects on Projections	4-7
4.6.1	Imported Water Supply Contingency Planning	4-7
4.6.2	Graywater Use	4-8
4.6.3	Recycled Water Usage	4-9
4.6.4	Climate Change	4-10
4.6.5	Responses to Uncertainties in Projections.....	4-11
4.7	Wastewater Characteristics	4-12
4.7.1	Recent Characteristics.....	4-12
4.7.2	Recent and Historic Concentrations	4-13
4.7.3	Recent and Historic Loadings	4-14
4.7.4	Constituent Concentrations Review	4-14
4.7.5	Characteristics Summary.....	4-15
4.7.6	Effluent Quality.....	4-15
4.8	Wastewater Flow Projections	4-16
4.8.1	Methodology	4-16
4.8.2	Projected Wastewater Flows.....	4-19
4.8.3	Wastewater Flow Variations and Peaking	4-20
4.9	Wastewater Solids Projections	4-24
4.9.1	Solids Types and Sources	4-24
4.9.2	Recent Solids Production.....	4-25
4.9.3	Basis for Solids Projections	4-25
4.9.4	Solids Projections	4-26
4.10	Water Recycling and Reuse	4-26
4.10.1	Sanitation Districts' History of Water Recycling	4-26
4.10.2	Previous Studies	4-27
4.10.3	Chronology of Water Reuse Approvals.....	4-29
4.10.4	Current Reuse.....	4-30
4.10.5	Future Reuse	4-32
4.10.6	Reuse Challenges.....	4-35
Chapter 5	Existing Facilities Description and Needs Assessment	5-1
5.1	Joint Outfall System Overview	5-1
5.2	Conveyance System.....	5-1
5.2.1	Laterals and Local Sewers.....	5-2
5.2.2	District Trunk Sewers.....	5-2
5.2.3	Joint Outfall Trunk Sewers.....	5-2
5.2.4	Management Practices	5-3
5.3	Water Reclamation Plants	5-8
5.3.1	Pomona Water Reclamation Plant.....	5-9
5.3.2	San Jose Creek Water Reclamation Plant.....	5-9
5.3.3	Whittier Narrows Water Reclamation Plant.....	5-10
5.3.4	Los Coyotes Water Reclamation Plant	5-10
5.3.5	Long Beach Water Reclamation Plant	5-11
5.3.6	La Cañada Water Reclamation Plant.....	5-11
5.3.7	Water Reclamation Plant Process Capabilities.....	5-12

5.4	Water Reclamation Plant Effluent Management.....	5-17
5.4.1	Surface Water Discharge.....	5-17
5.4.2	Reclamation and Reuse.....	5-18
5.5	Joint Water Pollution Control Plant.....	5-18
5.5.1	Plant Description.....	5-19
5.5.2	Process Capabilities.....	5-19
5.6	JWPCP Effluent Management.....	5-22
5.6.1	Initial Tunnel and Ocean Outfalls.....	5-23
5.6.2	Subsequent Tunnel and Ocean Outfalls.....	5-24
5.6.3	Emergency Diversion.....	5-24
5.7	Solids Processing.....	5-24
5.7.1	Background.....	5-24
5.7.2	Solids Sources.....	5-25
5.7.3	Sludge Thickening.....	5-25
5.7.4	Sludge Stabilization.....	5-26
5.7.5	Sludge Dewatering.....	5-26
5.7.6	Gas Handling and Power Generation.....	5-27
5.8	Biosolids Management.....	5-27
5.8.1	Biosolids Management History.....	5-27
5.8.2	Biosolids Strategy.....	5-28
5.8.3	Recent Management Practices.....	5-28
5.8.4	Landfill Co-Disposal.....	5-29
5.8.5	Future Solids Management.....	5-30
5.9	Joint Outfall System Needs Assessment.....	5-31
5.9.1	Conveyance System.....	5-32
5.9.2	Treatment Plants.....	5-33
5.9.3	Solids Processing.....	5-34
5.9.4	Biosolids Management.....	5-35
5.9.5	Water Reclamation Plant Effluent Management.....	5-35
5.9.6	Joint Water Pollution Control Plant Effluent Management.....	5-35
Chapter 6	Alternatives Analysis.....	6-1
6.1	Introduction.....	6-1
6.1.1	Chapter Organization.....	6-1
6.1.2	Planning Objectives.....	6-1
6.1.3	Managing Uncertainty.....	6-1
6.1.4	Public Input.....	6-2
6.1.5	Terminology.....	6-2
6.2	Program Analysis by Program Component Area.....	6-3
6.2.1	Alternatives Development and Analysis Process.....	6-3
6.2.2	Wastewater Conveyance and Treatment (CT).....	6-10
6.2.3	Solids Processing (SP).....	6-27
6.2.4	Biosolids Management (BM).....	6-31
6.2.5	WRP Effluent Management (WE).....	6-34
6.2.6	JWPCP Effluent Management (JE).....	6-36
6.3	Project Analysis by Project Elements.....	6-43
6.3.1	Alternatives Development and Analysis Process.....	6-43
6.3.2	Study Area.....	6-43
6.3.3	Evaluation of Project Elements.....	6-44

	6.3.4	Development and Screening of Project Alternatives	6-51
6.4		Final Plan Alternatives	6-57
	6.4.1	Viable Alternatives	6-57
	6.4.2	No-Project and No-Federal-Action Alternatives	6-58
	6.4.3	Identification of Recommended Plan	6-58
Chapter 7		Recommended Plan Summary	7-1
	7.1	Introduction	7-1
	7.2	Summary of the Recommended Plan	7-1
		7.2.1 Wastewater Conveyance and Treatment	7-2
		7.2.2 Solids Processing	7-3
		7.2.3 Biosolids Management	7-4
		7.2.4 WRP Effluent Management	7-4
		7.2.5 JWPCP Effluent Management (Project)	7-5
	7.3	Plan Implementation and Schedule	7-7
	7.4	Project Cost	7-7
		7.4.1 Upgrade and Expansion Costs	7-8
	7.5	Revenue Program	7-9
		7.5.1 Service Charge Program	7-9
		7.5.2 Connection Fee Program	7-11
		7.5.3 Additional Sources of Revenue	7-12
	7.6	Project Financing	7-13
		7.6.1 Available Financing Sources	7-13
		7.6.2 Financing Analysis	7-13
		7.6.3 Opportunities for Public Input	7-14

LIST OF TABLES

Table	Page
2-1 Cities Located Within the Clearwater Program Planning Area.....	2-1
2-2 Joint Outfall System Service Area Monthly Climate Summary.....	2-2
2-3 Population Estimates in Los Angeles County and Joint Outfall System Service Area From 1970 to 2010	2-5
2-4 Ethnic and Racial Population Composition in Joint Outfall System Service Area and Los Angeles County From 1970 to 2010	2-5
2-5 Dwelling Units in Joint Outfall System Service Area and Los Angeles County From 1970 to 2000.....	2-6
2-6 Vacancy Rate and Persons per Household in Los Angeles County From 1980 to 2010	2-6
2-7 Median Household Income in Joint Outfall System Service Area and Los Angeles County From 1970 to 2009.....	2-6
2-8 Civilian Jobs in the Southern California Association of Governments Region, Los Angeles County, and the Joint Outfall System Service Area From 1970 to 2009	2-7
3-1 Industrial Wastewater Discharge Limits	3-3
3-2 Permit and Order Numbers for JOS Plants	3-6
3-3 NPDES Permit Final Effluent Limits for Conventional and Non- Conventional Constituents for WRP Discharges.....	3-8
3-4 WRP Recharge and Reuse Permit Limits	3-9
3-5 NPDES Permit Limits for Major Wastewater Constituents for JWPCP Ocean Discharge.....	3-12
3-6 NPDES Permit Limits for Marine Aquatic Life Toxicants for JWPCP Ocean Discharge Points 001 and 002.....	3-13
3-7 NPDES Permit Limits for Human Health Toxicants (Carcinogens) for JWPCP Ocean Discharge Points 001 and 002	3-13

3-8	NPDES Permit Limits for Marine Aquatic Life Toxicants for JWPCP Ocean Discharge Points 003 and 004.....	3-13
3-9	NPDES Permit Limits for Human Health Toxicants (Carcinogens) for JWPCP Ocean Discharge Points 003 and 004	3-14
3-10	NPDES Permit Performance Goals for JWPCP Ocean Discharge Points 001 and 002	3-14
3-11	JWPCP Receiving Water Bacteria Limits.....	3-16
3-12	Additional Prohibitions on Effects on Receiving Water by the JWPCP Discharge	3-17
3-13	Suitable Uses of Recycled Water.....	3-19
3-14	Environmental Protection Agency Marine Engine Categories.....	3-27
3-15	SCAQMD Rules for Stationary Sources.....	3-31
3-16	Pollutant Concentration Standards for Biosolids	3-32
4-1	Climate Change Impacts in the Southwest	4-11
4-2	JOS Recent Wastewater Characteristics by Treatment Plant (2007–2009 Averages).....	4-13
4-3	Comparison of Recent (2007–2009) and Historical Wastewater Parameters.....	4-14
4-4	Comparison of Recent (2007–2009) and Historical Wastewater Loads.....	4-14
4-5	Per-Capita Flow Generation Results for JOS Tributary Area.....	4-17
4-6	Residential Land Use Types and Corresponding SFR Equivalentents	4-18
4-7	Residential Population Projections.....	4-19
4-8	2050 Wastewater Flow Projections by Component Source for the JOS.....	4-19
4-9	2050 Projected Tributary Flows for the JOS Treatment Plants	4-20
4-10	Water Reclamation Plant Sanitary Flow Peaking Factors.....	4-21
4-11	Water Reclamation Plant Wet Weather Flow Peaking Factors	4-22
4-12	Summary of Predicted Flows at the JWPCP.....	4-24
4-13	Population and Solids Production Summary	4-25

4-14	Reuse by WRP for Fiscal Year 2009–10.....	4-31
4-15	Summary of Total Projected Recycled Water Use Within the JOS by 2050	4-35
5-1	Lengths of Sewers Located in Each District.....	5-2
5-2	Lengths of District Trunk Sewers	5-3
5-3	Permitted Dry Weather Storm Drain Diversions.....	5-7
5-4	Water Reclamation Plant Design Criteria.....	5-12
5-5	Water Reclamation Plant Permitted and Site Capacities	5-15
5-6	Joint Water Pollution Control Plant Process Design Criteria Summary	5-20
5-7	JWPCP Ocean Discharge System	5-23
5-8	Biosolids Management Practices Summary.....	5-29
5-9	Landfill and Composting Facilities Within a 100-Mile Radius of the JWPCP.....	5-31
5-10	Projected Conveyance System Capacity Needs.....	5-33
5-11	Projected Joint Outfall System Treatment Plant Capacity Needs	5-33
6-1	Projected 2050 Tributary Flows and Site Capacities (MGD).....	6-15
6-2	Baseline Model Versus 2050 Flow – Identified Potential Joint Outfall Trunk Sewer Capacity Limitations.....	6-16
6-3	Potential Treatment Scenarios	6-17
6-4	CT Preliminary Options	6-17
6-5	Option CT 2A – SJC: Modules and Flows.....	6-18
6-6	Option CT 2A – SJC: Identified Potential Joint Outfall Trunk Sewer Capacity Limitations	6-18
6-7	Option CT 2B – SJC/PO/WN: Modules and Flows.....	6-19
6-8	Option CT 2B – SJC/PO/WN: Identified Potential Joint Outfall Trunk Sewer Capacity Limitations	6-19
6-9	Option CT 2C – SJC/PO: Modules and Flows	6-20

6-10	Option CT 2C – SJC/PO: Identified Potential Joint Outfall Trunk Sewer Capacity Limitations	6-20
6-11	Option CT 2D – SJC/WN: Modules and Flows.....	6-21
6-12	Option CT 2D – SJC/WN: Identified Potential Joint Outfall Trunk Sewer Capacity Limitations	6-21
6-13	Option CT 2E – SJC/LC: Modules and Flows	6-22
6-14	Option CT 2E – SJC/LC: Identified Potential Joint Outfall Trunk Sewer Capacity Limitations	6-22
6-15	Option CT 2F – SJC/LB: Modules and Flows.....	6-23
6-16	Option CT 2F – SJC/LB: Identified Potential Joint Outfall Trunk Sewer Capacity Limitations	6-23
6-17	Preliminary CT Options Summary	6-24
6-18	Comparison of Preliminary CT Options to Level 2 Screening Parameters.....	6-24
6-19	Level 3 Screening Parameters and Weighting	6-26
6-20	Viable Options Scoring Summary	6-26
6-21	Comparison of Preliminary Options to Level 2 Screening Parameters	6-30
6-22	Comparison of Preliminary Options to Level 2 Screening Parameters	6-33
6-23	Comparison of Preliminary Options to Level 2 Screening Parameters	6-41
6-24	Viable Alternatives: New Ocean Discharge System.....	6-52
6-25	Viable Alternatives: Modified Ocean Discharge System	6-52
6-26	Screening Parameters and Weighting.....	6-53
6-27	Project Element Importance Factors	6-54
6-28	Viable Alternatives Scoring Summary	6-55
6-29	Grouping of Viable Alternative by Intermediate Shaft Site and Diffuser Location.....	6-56
6-30	Feasible Plan Alternatives.....	6-57
6-31	Capital Costs for Feasible Plan Alternatives	6-58

7-1 Implementation Schedule for Modified Ocean Discharge System7-7

7-2 Capital and Annualized Capital Cost Breakdown of the
Recommended Project.....7-8

7-3 Capital Cost of Upgrade and Expansion Portions of the
Recommended Project.....7-9

7-4 Joint Outfall System Annual Service Charge Rates per Sewage Unit7-10

7-5 Joint Outfall System Connection Fee Rates per Capacity Unit7-11

LIST OF FIGURES

Figure	Follows Page
1-1 Sanitation Districts Service Area	1-1
1-2 Existing Joint Outfall System	1-3
2-1 Clearwater Program Planning Area	2-1
2-2 Major Geographic and Topographic Features of the HOS Service Area	2-2
2-3 Regional Faults in the JOS Service Area	2-3
2-4 Water Bodies Within the JOS Service Area	2-3
2-5 Regional Groundwater Basins	2-3
2-6 South Coast Air Basin	2-3
2-7 Population in the Joint Outfall System Service Area	2-4
2-8 Distribution of Population by Race and Ethnicity in Los Angeles County	2-5
4-1 Historical WRP Influent Suspended Solids Concentrations	4-15
4-2 Historical WRP Influent BOD Concentrations	4-15
4-3 Historical WRP Influent COD Concentrations	4-15
4-4 Historical WRP Influent TDS Concentrations	4-15
4-5 Historical JWPCP Influent Concentrations	4-15
4-6 Treatment Plant Tributary Areas	4-18
4-7 Historic and Projected Populations in the Joint Outfall System	4-19
4-8 Typical WRP Diurnal Flow Variations	4-20
4-9 Typical JWPCP Diurnal Flow Variations	4-21

4-10	Recycled Water Distribution System	4-30
4-11	Historical Recycled Water Production and Total Usage.....	4-30
4-12	Historical WRP Recycled Water Productions.....	4-30
4-13	Historical Recycled Water Use by WRP.....	4-30
4-14	Recycled Water Use by City Area	4-30
5-1	Joint Outfall System	5-1
5-2	Joint Outfall Trunk Sewer System	5-2
5-3	Pomona Water Reclamation Plant	5-9
5-4	San Jose Creek Water Reclamation Plant	5-9
5-5	Whittier Narrows Water Reclamation Plant	5-10
5-6	Los Coyotes Water Reclamation Plant.....	5-10
5-7	Long Beach Water Reclamation Plants.....	5-11
5-8	La Cañada Water Reclamation Plant	5-11
5-9	Generalized WRP Process Schematic.....	5-14
5-10	MLE Nitrogen Removal Process Schematic (WNWRP, POWRP)	5-14
5-11	SFA Nitrogen Removal Process Schematic (SJCWRP, LCWRP, LBWRP)	5-14
5-12	Joint Water Pollution Control Plant.....	5-19
5-13	JWPCP Process Flow Schematic	5-19
5-14	Joint Water Pollution Control Plant Existing Ocean Discharge System	5-22
5-15	Biosolids Management Facilities	5-29
5-16	Conveyance System Needs	5-33
5-17	Projected 2050 JOS Flows Versus Total Existing Permitted Capacity.....	5-34
5-18	Projected 2050 JOS Biosolids Generation Rates.....	5-35
6-1	Master Facilities Plan Program-Level Alternatives Screening Process.....	6-3

6-2	Master Facilities Plan Program-Level Alternatives Screening Process.....	6-43
6-3	Master Facilities Plan Project-Level Alternatives Screening Process	6-43
6-4	Study Area for a New or Modified Ocean Discharge System.....	6-43
6-5	Preliminary Onshore Alignments.....	6-45
6-6	Viable Onshore Alignments.....	6-46
6-7	Preliminary Viable JWPCP Shaft Sites	6-46
6-8	Preliminary Intermediate Shaft Sites	6-48
6-9	Viable Intermediate Shaft Sites	6-49
6-10	Preliminary Diffuser Areas.....	6-49
6-11	Viable Diffuser Areas.....	6-50
6-12	Preliminary Offshore Alignments.....	6-51
6-13	Viable Alternatives for a New or Modified Ocean Discharge System.....	6-52
6-14	Feasible Alternatives for New or Modified Ocean Discharge System	6-56
6-15	Master Facilities Plan Project-Level Alternatives Screening Process	6-56
7-1	Pomona Water Reclamation Plant Proposed Facilities.....	7-2
7-2	San Jose Creek Water Reclamation Plant Proposed Facilities.....	7-2
7-3	Los Coyotes Water Reclamation Plant Proposed Facilities	7-3
7-4	Long Beach Water Reclamation Plant Proposed Facilities	7-3
7-5	Conveyance System Improvements.....	7-3
7-6	Joint Water Pollution Control Plant Proposed Facilities	7-4
7-7	JWPCP West Shaft Site	7-5
7-8	JWPCP West Shaft Profile	7-5
7-9	Recommended Tunnel Alignment.....	7-5
7-10	Royal Palms Shaft Site.....	7-6
7-11	Royal Palms Shaft Profile.....	7-6

LIST OF APPENDICES

Appendix A	State Water Resources Control Board Requirements for Project Reports
Appendix B	Sanitation Districts That Provide Service to Local Jurisdictions
Appendix C	Design Criteria for the San Jose Creek Water Reclamation Plant
Appendix D	References
Appendix E	List of Preparers and Contributors
Appendix F	List of Abbreviations

Chapter 1 INTRODUCTION

1.1 Background

The Sanitation Districts of Los Angeles County (Sanitation Districts) have prepared the Clearwater Program Master Facilities Plan (MFP) to identify a recommended plan that will meet the wastewater management needs of the Joint Outfall System (JOS) through the year 2050. The associated joint environmental impact report/environmental impact statement (EIR/EIS), available under separate cover, was prepared by the environmental consulting firm ICF International. An executive summary for both the MFP and EIR/EIS is also available under separate cover. The Sanitation Districts are the lead agency for the EIR under the California Environmental Quality Act, and the U.S. Army Corps of Engineers is the federal lead agency for the EIS under the National Environmental Policy Act. The Clearwater Program MFP and EIR/EIS were prepared in conformance with the California State Water Resources Control Board's policy for implementing the Clean Water State Revolving Fund (SRF) Program for construction of wastewater management facilities. A summary of the SRF requirements is provided in Appendix A of this document.

1.2 Sanitation Districts of Los Angeles County

The Sanitation Districts are a regional organization consisting of 23 independent special districts serving the wastewater and solid waste management needs of approximately 5.4 million people in Los Angeles County. The Sanitation Districts' service area, shown on Figure 1-1, covers approximately 820 square miles and encompasses 78 cities and unincorporated territory within the county.

The Sanitation Districts were originally formed under authority provided by the County Sanitation District Act of 1923. This act authorized the formation of sanitation districts by drainage areas rather than political boundaries, thereby allowing for the economies of scale associated with the regionalization of wastewater services and facilities. In 1949, the act was amended to include solid waste management services.

The 23 independent districts that compose the Sanitation Districts work cooperatively under a Joint Administration Agreement (JAA) with one administrative staff headquartered near Whittier, California. Each district has a separate board of directors consisting of the presiding officers of the governing bodies of the local jurisdictions situated within that district. Each district is required to pay its proportionate share of the joint administration costs, pursuant to the terms of the JAA. Appendix B contains a list of jurisdictions served by the Sanitation Districts and the district(s) within each.

The Sanitation Districts' 1,400 miles of main trunk sewers and 11 wastewater treatment plants convey and treat about half the wastewater in Los Angeles County. The total permitted capacity of the 11 wastewater treatment plants is 650 million gallons per day (MGD). The Sanitation Districts' solid waste management sites provide about one-third of the countywide solid waste management needs. The Sanitation Districts operate three sanitary landfills, four landfill energy recovery facilities, two recycle

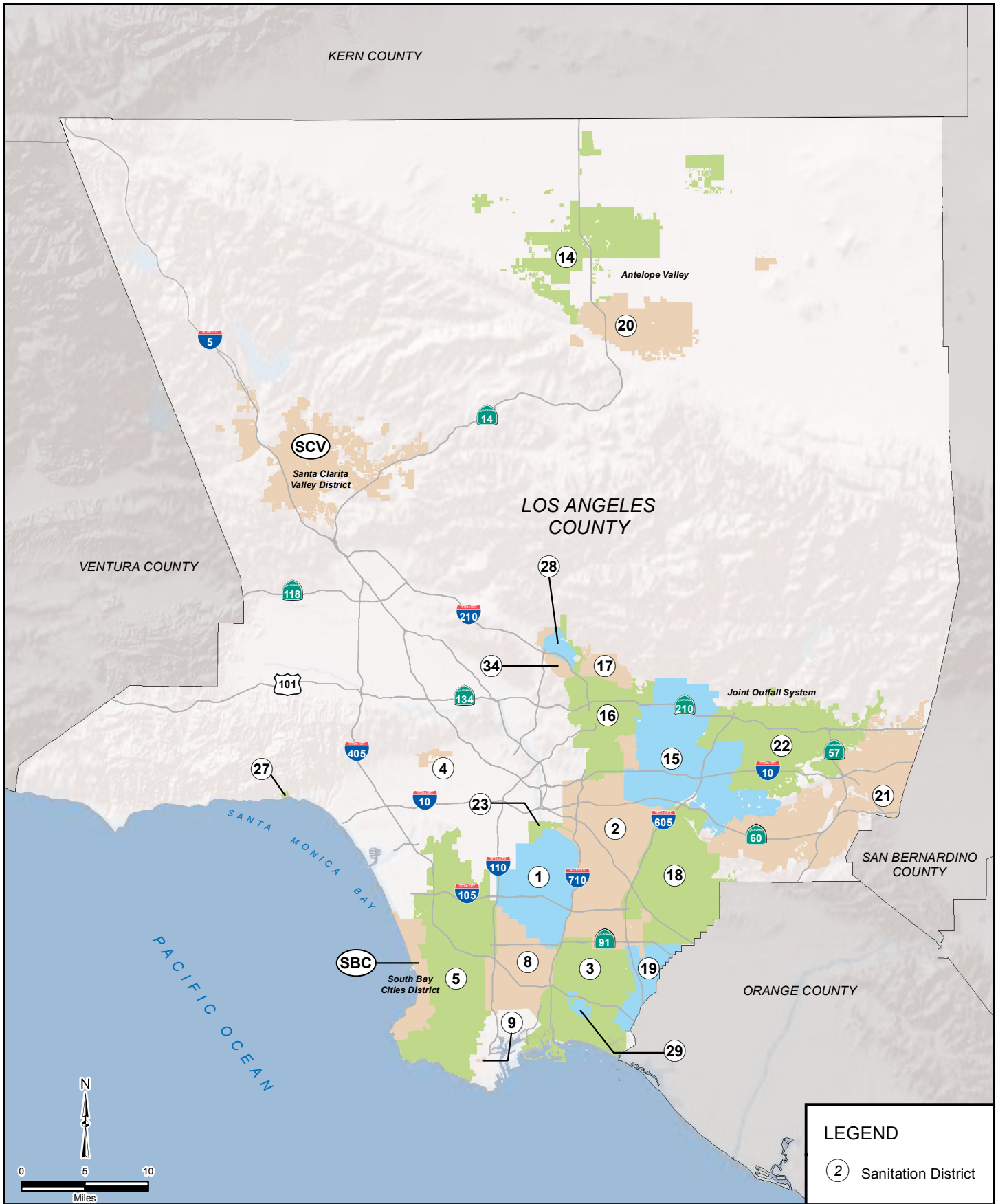

LEGEND
 (2) Sanitation District

FIGURE 1-1

centers, and three materials recovery/transfer facilities, and participate in the operation of two refuse-to-energy facilities.

1.2.1 Mission Statement

The Sanitation Districts' mission is *to protect public health and the environment through innovative and cost-effective wastewater and solid waste management, and in doing so convert waste into resources such as recycled water, energy, and recycled materials.*

1.2.1.1 Public Health and Environmental Protection

The Sanitation Districts are committed to the protection of public health and the environment. The evolution of proper sanitary practices, including wastewater and solid waste management, has virtually eliminated waterborne disease in the United States and contributed to a longer life expectancy. The tertiary-treated wastewater produced by the Sanitation Districts, which essentially meets or exceeds state and federal drinking water standards, is safe for indirect potable reuse and unrestricted direct human contact (e.g., swimming). The proper disposal of refuse prevents the spread of pathogens and disease, while advanced landfill liner and gas collection systems ensure the preservation of groundwater and air quality.

1.2.1.2 Innovative and Cost-Effective Services

The Sanitation Districts' wastewater and solid waste management systems provide essential public services at some of the most competitive rates in Southern California and the rest of the country. Over the years, the Sanitation Districts have consistently engaged in research and studies; designed and constructed state-of-the-art conveyance, treatment, and disposal facilities; and pioneered efficiencies in operations and maintenance. These innovations have proven integral in controlling overall costs.

1.2.1.3 Water Reclamation and Reuse

In 1949, the Chief Engineer and General Manager of the Sanitation Districts prepared a visionary report recognizing the key role that highly treated wastewater (recycled water) would have in Southern California. The report recommended the adoption of a policy looking toward reclamation. The first water reclamation plant (WRP) was built in 1962. In 2010, the Sanitation Districts' ten WRPs produced approximately 165 MGD of high-quality recycled water. Approximately 84 MGD (93,000 acre-feet per year¹) of recycled water was reused at 640 sites throughout Los Angeles County. Uses include groundwater recharge; industrial, commercial, and recreational applications; habitat maintenance; and agricultural and landscape irrigation. Assuming this water would otherwise have been supplied by imported water, these recycled water efforts have avoided approximately 250,000 megawatt hours (MWh) of annual power consumption, offsetting 73,000 metric tons of carbon dioxide equivalents (CO₂e).

1.2.1.4 Beneficial Use of Biosolids

Biosolids are a byproduct of the wastewater treatment process. The Sanitation Districts produce approximately one-half million tons of biosolids each year. As part of the treatment process, biogas is produced and is then converted to electricity or utilized for process heating. Biosolids have been

¹ One acre-foot is the approximate amount of water used by two single family homes in Southern California each year.

beneficially used for a variety of applications, including as an ingredient in high-quality compost, a soil amendment for agriculture, and an emissions-reducing agent in cement kilns.

1.2.1.5 Green Energy Production and Use

The Sanitation Districts, having successfully pioneered renewable energy technologies at their wastewater and solid waste facilities, are leaders in the production and use of green power. The production of renewable energy from biogas conserves fossil fuels and reduces greenhouse gas emissions. In 2010, the Sanitation Districts produced 750,000 MWh of power offsetting 220,000 metric tons of CO₂e. This is enough renewable energy to power 120,000 homes.

1.3 Joint Outfall System

Consistent with the Sanitation Districts' regional approach to wastewater management, 17 of the districts participate in the Joint Outfall Agreement (JOA), which provides for a combined investment in wastewater conveyance and treatment facilities. These 17 districts, collectively known as the Joint Outfall Districts, are located in the metropolitan Los Angeles area in the eastern and southern portions of Los Angeles County. The Joint Outfall Districts extend south from the San Gabriel Mountains to the Palos Verdes Peninsula and are bound on the east by Orange and San Bernardino Counties, on the west by the Santa Monica Bay and the cities of Glendale and Los Angeles, and on the south by the San Pedro Bay. District No. 2 is the appointed agent for the 17 districts with respect to matters necessary to carry out the purposes of the JOA.

The Joint Outfall Districts have constructed a regional, interconnected system of wastewater conveyance and treatment facilities known as the Joint Outfall System, or JOS, shown on Figure 1-2. The JOS provides wastewater management services for 4.8 million people in 73 cities as well as some unincorporated areas of Los Angeles County. The service area, which covers 660 square miles, generally slopes downward from the northeast to the southwest. The JOS was designed to take advantage of this regional topography. Wastewater is collected by approximately 8,500 miles of city- and county-owned local sewers and then conveyed, primarily via gravity, through the Sanitation Districts' 1,230 miles of sewers that interconnect seven JOS wastewater treatment plants with a total treatment capacity of 592.5 MGD. The JOS service area, the individual district boundaries, and the location of wastewater treatment plants are shown on Figure 1-2.

1.3.1 JOS Wastewater Treatment System

The JOS has conceptually developed into two wastewater treatment subsystems: a downstream (or coastal) subsystem and an upstream (or inland) subsystem.

The coastal subsystem consists of the Joint Water Pollution Control Plant (JWPCP), which is located in the city of Carson at the terminus of the JOS trunk sewer network. The JWPCP, which has a permitted capacity of 400 MGD, is the Sanitation Districts' largest wastewater treatment facility. It provides secondary treatment and disinfection to all influent wastewater. All JWPCP effluent (treated wastewater) is discharged one and a half miles out in Pacific Ocean. The JWPCP also provides centralized solids processing for all JOS wastewater treatment facilities.

The inland subsystem consists of six upstream WRPs that provide higher levels of treatment to wastewater selectively routed from predominately residential areas. Residential wastewater is relatively low in dissolved solids, such as salts, so it is more suitable for reuse after treatment than industrial wastewater. The Pomona Water Reclamation Plant (POWRP), San Jose Creek Water Reclamation Plant



FIGURE 1-2

(SJCWRP), Whittier Narrows Water Reclamation Plant (WNWRP), Los Coyotes Water Reclamation Plant (LCWRP), and Long Beach Water Reclamation Plant (LBWRP) provide tertiary treatment, and the La Cañada Water Reclamation Plant (LACAWRP) provides disinfected, secondary treatment. The combined permitted capacity of the six upstream WRPs is 193 MGD. All recycled water produced at the WRPs that is not reused is discharged to nearby rivers or creeks and eventually flows to the ocean. All solids generated at the WRPs are returned to the JOS trunk sewer system and conveyed to the JWPCP for processing.

Overall, the Joint Outfall Districts realize several significant benefits that stem from being divided into two wastewater treatment subsystems. First, it facilitates the partial segregation of easily reclaimable wastewater with low dissolved solids from wastewater with high dissolved solids through the selective routing of residential and industrial flows. Second, recycled water is made available to the locations where reuse demands are greatest with minimal need for distribution systems and pumping. Third, the upstream locations of the WRPs provide hydraulic relief for the downstream wastewater conveyance system, which reduces the capital costs associated with constructing new relief sewers. Finally, the downstream location of the JWPCP allows for economies of scale associated with centralized solids processing and ocean disposal of effluent that is too salty for reuse.

1.3.2 JOS Conveyance System

The Sanitation Districts own, operate, and maintain over 1,230 miles of sewers in the JOS. However, the majority of the sewer lines located within the boundaries of the JOS are the responsibility of private property owners or local jurisdictions. In general, the conveyance system consists of four types of sewers. Ranging from smallest to largest, these include lateral lines, local sewer lines, district trunk sewers, and Joint Outfall (JO) trunk sewers. The privately owned lateral lines connect residences and businesses to the local sewers. The local sewers that feed into the district trunk sewers are generally owned, operated, and maintained by the local cities or Los Angeles County's Consolidated Sewer Maintenance District. The Sanitation Districts' trunk sewers are the responsibility of the individual districts within which they are located. The purpose of these lines is to collect wastewater from the local sewers and convey it to the larger JO trunk sewers. The JO trunk sewers form the backbone of the regional conveyance system, and are owned, operated, and maintained by the Joint Outfall Districts. Approximately 480 miles of the JOS sewers are JO trunk sewers.

The JOS conveyance system also includes 50 pumping plants, which are located in areas where wastewater will not flow by gravity to the treatment plants. However, because the JOS was designed to take advantage of the slope of regional topography, the need for pumping plants and the associated energy costs are minimized.

1.3.3 JOS Ocean Discharge System

The JOS ocean discharge system consists of two onshore tunnels, a manifold structure, and four offshore ocean outfalls. The two 6-mile long onshore tunnels convey effluent from the JWPCP to the manifold structure located at Royal Palms Beach near White Point. The first tunnel was constructed in 1937 and is 8 feet in diameter; the second was constructed in 1958 and is 12 feet in diameter. The manifold structure is an underground reinforced concrete vault where the effluent transitions from the two tunnels to four ocean outfalls. A system of valves controls which of the four ocean outfalls are active at any given time. The outfalls extend seaward from the manifold structure. Approximately 1,400 feet offshore, the ocean outfalls change from underground pipelines to seafloor pipelines. The 60-inch diameter outfall was constructed in 1937, the 72-inch diameter outfall was constructed in 1947, the 90-inch diameter outfall was constructed in 1957, and the 120-inch diameter outfall was constructed in 1966. The effluent is

discharged through diffusers (i.e., the section of the outfall pipelines containing open portholes) up to one and a half miles offshore at a depth of approximately 200 feet below sea level.

1.3.4 JOS Planning History

JOS facilities planning has evolved in response to the historic patterns of population growth, changing regulatory standards, and the needs of the JOS service area. During the early years (1924–1945), when the population of Los Angeles County more than doubled from 1.6 million to 3.2 million, the Sanitation Districts emphasized the economic and administrative advantages of a regional collection and disposal system. The Sanitation Districts' regional approach to wastewater management fostered cooperation between neighboring communities that led to mutually agreeable solutions to waste management problems and avoided legal disputes.

The early development of the JOS included a tributary network of trunk sewers that was gradually expanded to accommodate growth in the Los Angeles Basin. The JWPCP provided primary treatment to all influent wastewater, and all effluent was discharged to the ocean. As growth continued in northern and eastern portions of the county, the regional consolidation of sewerage facilities continued as local wastewater treatment plants in several cities were retired and sewers were constructed to convey flow to the JWPCP.

Also during this period, it became apparent that continued growth in this region would be limited by the availability of resources, especially water. Consequently, the Metropolitan Water District of Southern California was formed in 1928 to design and construct facilities to import water to Southern California from the Colorado River. In 1941, the Colorado River Aqueduct was completed and deliveries of imported water to Southern California began soon thereafter.

In the years following World War II (1945–1965), the population of Los Angeles County again more than doubled as thousands of war industry employees and their families remained in Southern California. This marked the beginning of Southern California's heavy dependence on imported water supplies. Despite the import of water from the Colorado River, the Los Angeles Basin's demands for water had outgrown the sustainable yields of local aquifers by 1954. By 1960, local aquifers within the Los Angeles Basin were being significantly overdrawn, and groundwater levels in several wells had declined considerably.

In response to the pressing need to develop new water supplies, the Sanitation Districts' JOS facilities planning began to focus not only on the concept of accommodating growth in the Los Angeles Basin, but also on the ability to augment the regional water supply through water recycling. In the early 1960s, wastewater flows in the JOS began to approach the capacity limits of downstream trunk sewers. A plan was developed to build WRPs at inland sites as an alternative to the massive expansion of the downstream sewer system and the JWPCP that would have otherwise been necessary. Studies found that it was economically feasible to withdraw wastewater with relatively low dissolved solids concentrations from the largely residential northern and eastern portions of the JOS and treat it to a level such that it would be suitable for reuse. The proposed inland WRPs were, thus, intended to serve two purposes: to provide hydraulic relief for downstream sewers and the JWPCP and to provide an alternative water source to the over-drafted aquifers of the Los Angeles Basin.

The basic considerations for water recycling in the JOS were first identified in a 1949 report prepared by the Sanitation Districts. A subsequent report in 1958 reaffirmed the findings of the 1949 report and called for the construction of the WNWRP to demonstrate the feasibility of full-scale water reclamation. The rationale for inland water recycling on a system-wide level in the JOS was formally presented in

Sanitation Districts' plans prepared during the early 1960s, first in the 1963 A Plan for Water Reuse and later in the 1965 Plan A.

1.3.4.1 A Plan for Water Reuse (1963)

In 1963, A Plan for Water Reuse (Parkhurst 1963) was prepared at the request of the Sanitation Districts' Board of Directors. This report concluded that inland water reclamation would (1) augment the Los Angeles Basin's water resources, (2) avoid the capital-intensive alternative of providing hydraulic relief capacity in large diameter downstream sewers, and (3) achieve "pay-as-you-go" financing of sewerage facilities through modular plant expansions scheduled at time intervals based on actual population growth rates. This report called for numerous relatively small WRPs located near potential recycled water users throughout the JOS. The report was intended to provide a basis for immediate action and for future facilities planning.

1.3.4.2 Plan A (1965)

In October 1965, the Sanitation Districts' Boards of Directors adopted Plan A (Sanitation Districts 1965), a long-range master plan for the development of the JOS through the year 2005. Central to this master plan was the staging of three new relatively large inland secondary treatment plants beside the San Gabriel River, and expansion of the existing WNWRP. The modular expansion of inland plants would provide maximum reuse potential, as well as timely hydraulic relief of trunk sewers leading to the JWPCP.

1.3.4.3 JOS Facilities Plan (1977)

During the early 1970s, legislative actions of the state and federal governments, combined with a decrease in the rate of population growth in Los Angeles County and the planned implementation of the State Water Project to bring water from Northern California to Southern California, changed the basic assumptions under which Plan A was developed. Actions by the Los Angeles Regional Water Quality Control Board (LARWQCB) under the Porter Cologne Water Quality Act of 1970 required changes in solids removal and biosolids management at the JWPCP to meet more rigorous effluent standards. In 1972, the State Ocean Plan and the Clean Water Act (CWA) required several major changes in the JOS including the provision of full secondary treatment at the JWPCP and the implementation of an industrial source control program to control discharges of heavy metals, synthetic organic pollutants, and other incompatible pollutants to the sewer system.

In response, tertiary treatment facilities were constructed at JOS WRPs. The implementation of the State Water Project effectively improved the mineral quality of the water supply and wastewater. It also increased the costs and energy requirements associated with conventional water supplies. The totality of these changes warranted a re-evaluation of the 1965 JOS Plan A, which ultimately took the form of the 1977 JOS Facilities Plan (1977 Plan) (Sanitation Districts 1977).

The stated goals of the 1977 Plan were to (1) bring the JOS into compliance with state and federal water quality legislation, (2) provide wastewater conveyance, treatment, and disposal facilities necessary to serve the population tributary to the JOS through the year 2000, and (3) maximize the potential for water reuse in the JOS. At the time the 1977 Plan was developed, wastewater management agencies located in critical air basins were required to base their facilities plans on the lowest population projection for the service area. Therefore, the 1977 Plan was based on California Department of Finance (DOF) Series E-0 population projection that identified a zero-growth condition in the JOS during the planning period (1976–2000).

Accordingly, the 1977 Plan recommended system upgrades and emphasized inland treatment and reuse of wastewater. Proposed system upgrades included the construction of facilities to provide full secondary treatment at the JWPCP and tertiary treatment at all WRPs. To facilitate increased water reuse in the JOS, the 1977 Plan proposed to expand the aggregate capacity of the WRPs from 125 to 150 MGD (through expansions at the LBWRP and SJCWRP) while downscaling the permitted capacity of the JWPCP from 385 MGD to between 265 and 300 MGD.

1.3.4.4 JOS 2010 Master Facilities Plan (1995)

During the 1980s, the actual JOS population growth rate was higher than that predicted by the 1977 Plan. The original population projection for the year 2000 was 3.65 million, while the actual population in 1995 was approximately 4.6 million. This difference resulted in the generation of significantly larger wastewater flows within the JOS. The 1977 Plan predicted year 2000 flows between 415 and 450 MGD. In 1989, the actual JOS flows were approximately 524 MGD. These larger flows necessitated the accelerated construction of projects recommended in the plan as well as the additional expansion of facilities beyond the plan's recommendations. The permitted capacity of the JWPCP remained at 385 MGD.

In the late 1980s and early 1990s, the JOS experienced a decrease in wastewater flows. One contributing factor was weather- and water-supply-related. Drought conditions occurred and were accompanied by water restrictions that reduced per-capita wastewater generation within the JOS. Also during this period, there was an economic downturn that affected commercial and industrial wastewater generation. The overall result was that the 1995 flows were down to 470 MGD from the 1989 high of 524 MGD.

Following the completion of the 1977 Plan, amendments to the CWA were implemented including Section 301(h), which allowed the EPA to modify the requirements for full secondary treatment of municipal wastewater for ocean discharge. To obtain a 301(h) waiver, an applicant was required to demonstrate no adverse impact on the marine environment from discharge. In the state of California, requirements for marine discharge are also specified in the State Ocean Plan. The Sanitation Districts determined that both the federal and state requirements could be achieved by chemically enhanced primary treatment and partial secondary treatment. The Sanitation Districts constructed these facilities at JWPCP and applied for the modification to full secondary treatment requirements per Section 301(h). Ultimately, this permit modification was not granted, and the Sanitation Districts negotiated a consent decree that included the implementation of full secondary treatment at the JWPCP.

The planning review required by the terms of this consent decree was contained within the JOS 2010 Master Facilities Plan (2010 Plan) published in 1995 (Sanitation Districts 1995a). The stated planning objectives for the 2010 Plan were to (1) provide full secondary treatment for all flows as required by a Consent Decree between the Sanitation Districts, the United States, the state of California, the Natural Resources Defense Council, and Heal the Bay, and (2) provide wastewater conveyance, treatment, and reclamation/disposal facilities to meet JOS service area needs through the year 2010 in a cost-effective and environmentally sound manner.

There were two sets of recommendations in the 2010 Plan. The first was for 400 MGD of secondary treatment capacity at the JWPCP. The plan provided detailed design criteria, site layouts, and a schedule indicating the implementation and commencement of facilities operation by the year 2002. The second set of recommendations were presented with less detail and called for the expansion of the SJCWRP from 100 to 125 MGD by the year 2006 and expansion of the LCWRP from 37.5 to 50 MGD by 2008.

The recommended improvements to the JWPCP were implemented. To date, neither the SJCWRP nor the LCWRP expansions have been implemented because the projected increases in system flows have not materialized and additional treatment capacity has not been needed.

1.3.4.5 JOS Nitrification/Denitrification Facilities Plan (2001)

The POWRP, SJCWRP, WNWRP, LCWRP, and LBWRP discharge effluent into the San Gabriel River or its tributaries. Discharge requirements are contained within the NPDES permits for each plant. In the early 2000s, the permit renewals for these facilities included limitations for ammonia, total inorganic nitrogen, and trihalomethanes based on the Basin Plan adopted by the LARWQCB in June 1994.

Process modifications were required at the WRPs to consistently achieve the established limits. In 2001, a Nitrification/Denitrification Facilities Plan (NDN Plan) (Sanitation Districts 2001) was prepared to address these changes to permit requirements. The stated objective of the NDN Plan was to identify, evaluate, and recommend those actions that the Sanitation Districts must take to consistently comply with the water quality objectives for ammonia, total inorganic nitrogen, trihalomethanes, and disinfection for the five WRPs by June 2003.

The recommended project alternative was to convert the subject WRPs from conventional activated sludge to the NDN process, provide ammonia addition capabilities, and complete studies demonstrating that the receiving waters are amenable to site-specific water quality objectives. All the WRPs have since been modified as recommended in the NDN Plan and are meeting discharge limits.

1.4 Clearwater Program

The Sanitation Districts are in the planning stage of the Clearwater Program. The overall goal of the MFP is *to identify a recommended plan that is protective of public health and will best meet the needs of the JOS through the year 2050 in a cost-effective and environmentally sound manner.*

1.4.1 Clearwater Program Objectives

The Clearwater Program has four primary objectives for the JOS:

- *Provide adequate system capacity to meet the needs of the growing population*
- *Provide for overall system reliability by allowing for the inspection, maintenance, repair, and replacement of aging infrastructure*
- *Provide support for emerging recycled water reuse and biosolids beneficial use opportunities*
- *Provide a long-term solution for meeting water quality requirements set forth by regulatory agencies*

These objectives are used to determine the viability of potential options and alternatives for meeting the goal of the Clearwater Program MFP.

1.4.1.1 System Capacity

JOS wastewater flow projections are evaluated in the MFP. The Southern California Association of Governments (SCAG) provided the Sanitation Districts with population forecasts through the year 2050 (SCAG 2008), which served as the basis for the flow projections. SCAG's population forecasts indicate the JOS service area population will increase to approximately 6.3 million by 2050. A geographic

information system (GIS) model was used to derive flow projections from the population data. The population increase will result in an average wastewater flow of about 612 MGD by the year 2050. Based on these projections, the JOS system will experience a treatment capacity shortfall of approximately 20 MGD by the year 2050.

1.4.1.2 Aging Infrastructure

The Sanitation Districts' philosophy is to design, construct, and maintain reliable systems that have sufficient capacity and redundancy to provide the highest level of public safety and environmental protection. These systems are maintained with routine inspection, repair, and/or replacement as required. However, one critical component of the JOS, the onshore tunnels for the existing ocean discharge system, has not been inspected for over 50 years. Both tunnels cross the active Palos Verdes Fault, which is an additional area of concern. While the Sanitation Districts have no reason to believe serious problems exist with the tunnels, it is imperative they be properly inspected.

1.4.1.3 Emerging Reuse/Use Opportunities

Over 50 percent of recycled water produced by the six WRPs is reused at various sites throughout the local region, reducing the demand on potable freshwater sources, which in turn minimizes the need to import water. In addition, during the treatment process at the JWPCP, solids are treated to produce a biogas that is converted to electricity or used for process heating. As a result, the JWPCP is electrically self-sufficient, and excess electricity is supplied to the power grid. The Sanitation Districts also participate in a wide range of biosolids management programs that promote beneficial use of this wastewater byproduct. Biosolids are beneficially used in agriculture as a soil amendment, in the production of high quality compost, in conversion to renewable fuels, and to help reduce emissions from cement kilns. Environmental benefits associated with these biosolids management programs include a reduction in the consumption of energy and raw materials that would otherwise be required in the production of new materials. The Sanitation Districts are committed to continue supporting emerging recycled water reuse and biosolids beneficial use opportunities.

1.4.1.4 Water Quality Requirements

The Sanitation Districts maintain a strong record of compliance with water quality regulations and permit requirements. They have also assisted in the drafting and/or review of future requirements. The Sanitation Districts strive to continue providing long-term engineering solutions that meet the constantly evolving and increasingly stringent water quality requirements in a cost-effective and environmentally sound manner.

1.4.2 Project Purpose and Needs

Currently, the Sanitation Districts rely on two onshore tunnels and four offshore ocean outfall structures to convey effluent from the JWPCP in the city of Carson to the Pacific Ocean. The two tunnels were completed in 1937 and 1958 and have not been inspected for over 50 years. Inspection of the tunnels is not possible due to their overall length, limited access, interconnections between the tunnels, and continuous flow through the tunnels. Furthermore, in January 1995, the JOS service area was inundated by two major back-to-back storm events. The resulting peak wastewater flows in the sewerage system from these storm events nearly exceeded the capacity of the JWPCP ocean discharge system. If the tunnels were to be damaged or the capacity of the ocean discharge system exceeded, treated JWPCP effluent would need to be bypassed into the Wilmington Drain. If sufficient capacity were not available in the Wilmington Drain, the sewers tributary to the JWPCP could overflow and untreated wastewater

could enter various water courses such as the Dominguez Channel and the Los Angeles River. The project purpose and needs are to inspect and upgrade the aging ocean discharge system, to provide sufficient capacity in the JOS to accommodate the estimated 2050 peak wastewater flows, and to comply with all applicable water quality standards including regulations prohibiting sewer overflows. To meet these needs, the Clearwater Program evaluated either modifying the existing ocean discharge system or constructing a new ocean discharge system.

1.4.3 Clearwater Program Scope

The Clearwater Program MFP and the associated EIR/EIS provide both program-level and project-level alternatives analyses.

1.4.3.1 Program Analysis

The term *program* is used in reference to options or alternatives that would be implemented over a long period of time and do not have a high level of detail. The planning horizon for the MFP is the year 2050, and, because of long-term uncertainties, it would be too speculative to consider the specifics of projects that potentially would not be required for decades to come. Furthermore, the JOS is hydraulically interconnected, and changes to one component of the system could have ramifications on the rest of the system. Therefore, due to the uncertainties associated with a long-term planning horizon and the complex interrelationship between the elements of the JOS, the MFP includes a comprehensive, program-level alternatives analysis that evaluates the entire system. For the purposes of developing options and evaluating program alternatives, the JOS was broken down into the following five program component areas based on primary functionality:

- Wastewater conveyance and treatment
- Solids processing
- Biosolids management
- WRP effluent management
- JWPCP effluent management

This programmatic approach, which is presented in Chapter 6, ensures the long-term, system-wide viability of projects being considered in the near future.

1.4.3.2 Project Analysis

The term *project* is used to describe a specific component of the comprehensive program. A project would be implemented in the short term; therefore, a greater level of detail is available for analysis in the MFP and the associated EIR/EIS. As presented in Chapter 6, a potential project—a new or modified ocean discharge system for JWPCP effluent management—was identified through the program-level alternatives analysis process, which resulted in a separate, project-level alternatives analysis process. For the purposes of developing options and evaluating project alternatives, the potential JWPCP ocean discharge system was broken down into the following five project component areas based on primary functionality:

- JWPCP shaft site
- Onshore alignment
- Intermediate shaft site

- Offshore alignment
- Diffuser area

Technical feasibility and preliminary environmental analyses were conducted and public input was solicited to develop and rank specific project alignments.

1.4.4 Recommended Plan

The recommended plan, presented in Chapter 7, is a combination of the top-ranked program-wide alternative and the top-ranked project-specific alternative.

1.4.5 Public Outreach Program

Public outreach is vital to the success of the Clearwater Program. Since 2006, the Sanitation Districts have held a series of public workshops and agency scoping meetings in Carson, Wilmington, San Pedro, Rancho Palos Verdes, and Whittier; met with over 500 community leaders, civic groups, public officials, regulatory agencies, environmental groups, and businesses; circulated thousands of newsletters; and established a project website (www.ClearwaterProgram.org) and telephone information line. The California Water Environment Association and the Water Environment Federation have recognized these outreach efforts with state and federal public education awards.

1.5 Master Facilities Plan Organization and Content

This MFP consists of seven chapters and accompanying appendices. The chapters and content are:

- **Chapter 1 - Introduction:** Background information on the Sanitation Districts, the JOS, and the Clearwater Program planning process.
- **Chapter 2 - Planning Area Characteristics:** Overview of the planning area's physical and environmental characteristics.
- **Chapter 3 - Laws and Regulations:** Delineation of appropriate laws and regulations that have the potential to impact the planning process.
- **Chapter 4 - Water, Wastewater, and Projections:** Assessment of current conditions and projection of future population, flows, and characteristics.
- **Chapter 5 - Existing Facilities Description and Needs Assessment:** Summary of existing JOS facilities and system infrastructure, as well as a determination of future needs.
- **Chapter 6 - Alternatives Analysis:** Development, evaluation, and ranking of program and project alternatives to meet identified needs of the JOS through the year 2050.
- **Chapter 7 - Recommended Plan Summary:** Detailed summary of the recommended plan and revenue program.

Chapter 2

PLANNING AREA CHARACTERISTICS

2.1 Physical Setting

2.1.1 Clearwater Program Planning Area

The Joint Outfall System (JOS) service area is located in the central, southern, and eastern portions of Los Angeles County extending from the San Gabriel Mountain foothills south to the Palos Verdes Peninsula and San Pedro Bay, and from San Bernardino and Orange Counties west to the cities of Glendale and Los Angeles and to the Santa Monica Bay. The approximately 660-square-mile Clearwater Program planning area, which coincides with the sphere of influence (SOI) for the JOS, is shown on Figure 2-1. The SOI extends approximately 60 square miles beyond the current JOS service area boundary.

2.1.2 Communities Within the Planning Area

The Clearwater Program planning area encompasses 73 cities and portions of unincorporated Los Angeles County. Table 2-1 lists the cities located within the planning area.

Table 2-1. Cities Located Within the Clearwater Program Planning Area

Alhambra	Downey	Lomita	Rosemead
Arcadia	Duarte	Long Beach	San Dimas
Artesia	El Monte	Los Angeles	San Gabriel
Azusa	El Segundo	Lynwood	San Marino
Baldwin Park	Gardena	Manhattan Beach	Santa Fe Springs
Bell	Glendora	Maywood	Sierra Madre
Bell Gardens	Hawaiian Gardens	Monrovia	Signal Hill
Bellflower	Hawthorne	Montebello	South El Monte
Bradbury	Hermosa Beach	Monterey Park	South Gate
Carson	Huntington Park	Norwalk	South Pasadena
Cerritos	Inglewood	Palos Verdes Estates	Temple City
City of Commerce	Irwindale	Paramount	Torrance
City of Industry	La Cañada Flintridge	Pasadena	Vernon
Claremont	La Habra Heights	Pico Rivera	Walnut
Compton	La Mirada	Pomona	West Covina
Covina	La Puente	Rancho Palos Verdes	Whittier
Cudahy	La Verne	Redondo Beach	
Culver City	Lakewood	Rolling Hills	
Diamond Bar	Lawndale	Rolling Hills Estates	

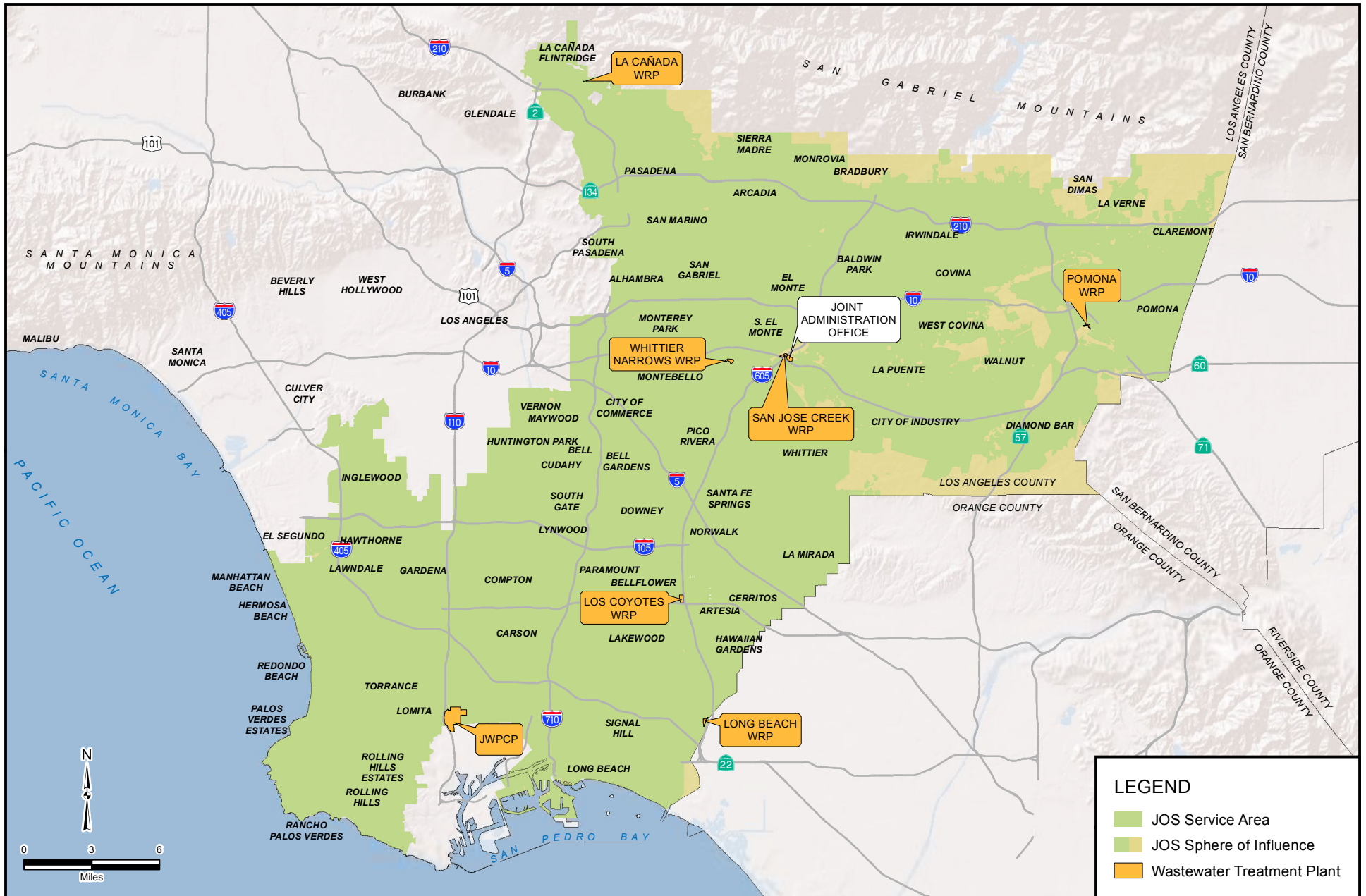

FIGURE 2-1

2.1.3 Climate

Prevailing winds in the Los Angeles Region emanate from the west and southwest. Moist air from the Pacific Ocean is carried inland into the Los Angeles Basin until it is forced upward by the surrounding mountains. The resulting storms, most common from November through March, are typically followed by dry periods during summer months. Differences in topography are responsible for large variations in temperature, humidity, precipitation, and cloud cover throughout the region. The coastal plains, which are noted for their subtropical “Mediterranean” climate, are characterized by pronounced seasonal changes in rainfall (mild rainy winters and warm dry summers) but relatively modest transitions in temperature. The inland slopes and basins are characterized by more extreme temperatures and little precipitation. Precipitation generally occurs as rainfall, although snowfall can occur at high elevations. Most precipitation occurs during a few major storms (LARWQCB 1995).

Average annual temperatures in the JOS service area range from a minimum of 52 degrees Fahrenheit (°F) to a maximum of 77°F. During the dry season (April through October), average temperatures range from 57°F to 81°F; during the wet season (November through March), the range is from 46°F to 70°F. Total annual precipitation is about 15 inches, averaging about 2 inches during the dry season and 13 inches during the wet season. A monthly climate summary for the JOS services area is shown in Table 2-2.

Table 2-2. Joint Outfall System Service Area Monthly Climate Summary

Parameter	Jan	Feb	Mar	Apr	May	Jun	Jul	Aug	Sep	Oct	Nov	Dec	Annual Average
Average Maximum Temperature (°F)	67.4	68.7	70.1	73.8	76.2	80.5	86.3	87.1	85.5	80.2	73.6	68.3	76.5
Average Minimum Temperature (°F)	43.6	45.2	47.1	50.0	54.0	57.5	61.3	62.1	60.2	55.1	48.0	43.7	52.3
Average Total Precipitation (inches)	3.3	3.6	2.5	1.0	0.3	0.1	0.0	0.1	0.2	0.5	1.4	2.2	15.2

Source: Los Angeles Almanac 2010

2.1.4 Geography and Topography

The JOS provides wastewater management services to communities within the San Gabriel Valley, the Los Angeles Coastal Plain, and the mountain foothills. Geographically, the JOS service area is bounded by the San Gabriel Mountains to the north, the Verdugo Mountains to the west, the Pacific Ocean to the west and south, and Orange and San Bernardino Counties and the Puente and San Jose Hills to the east. Major geographic and topographic features within and surrounding the JOS are shown on Figure 2-2. Due to the southward sloping topographic gradient within this area, the Los Angeles and San Gabriel Rivers and the Rio Hondo generally flow southward into the San Pedro Bay. The Sanitation Districts of Los Angeles County (Sanitation Districts) utilize the regional topography to provide gravity flow throughout the majority of the JOS service area. Further description of the regional geography and topography is provided in Chapter 8 of the Clearwater Program environmental impact report/ environmental impact statement (EIR/EIS).

2.1.5 Geology

The JOS service area occupies an area within two adjoining geomorphic provinces: the Peninsular Ranges and the Transverse Ranges. The Peninsular Ranges geomorphic province extends south from the southeastern terminus of the Santa Monica Mountains and the foothills of the San Gabriel Mountains into Baja California and includes the southern portion of the JOS service area. The Transverse Ranges

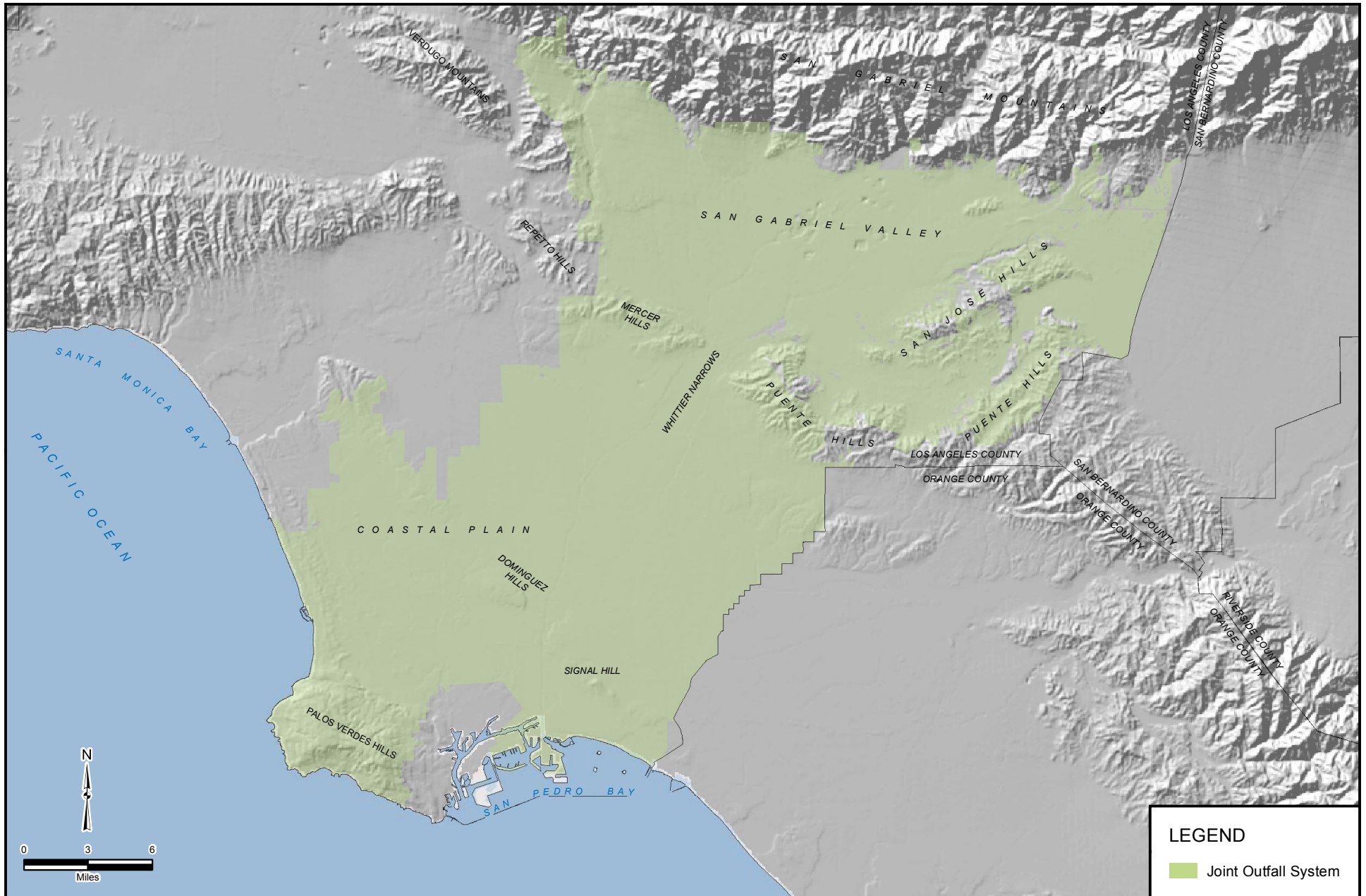

FIGURE 2-2

Major Geographic and Topographic Features within the JOS

geomorphic province trends east-west along the northern border of the Peninsular Ranges geomorphic province and includes the northern portion of the JOS service area. The Coastal Plain lies within the Peninsular Ranges geomorphic province, while the San Gabriel Valley lies within the transition zone separating these two geomorphic provinces.

As shown on Figure 2-3, the JOS service area is located in a seismically active region. Because of the number of active faults in Los Angeles County, the JOS service area is within the highest seismic hazard risk zone as defined by both the California Department of Conservation Division of Mines and Geology and the Uniform Building Code standards. Further description of the regional geology is provided in Chapter 8 of the Clearwater Program EIR/EIS.

2.1.6 Hydrology

The major hydrologic features in the JOS service area are the Los Angeles River Basin, San Gabriel River Basin, and Los Angeles Coastal Plain as identified in the Water Quality Control Plan, Los Angeles Region, Basin Plan for the Coastal Watersheds of Los Angeles and Ventura Counties. Precipitation in the Los Angeles area is characterized by intermittent but regular rainfall during winter months, with 85 percent of the annual precipitation occurring between November and March. Rainfall during the summer months is usually negligible. Precipitation as snow is common in higher elevations of the upper watersheds of the San Gabriel Mountains. Monthly precipitation totals are quite variable, but annual precipitation usually averages 10 to 20 inches. Annual precipitation typically is highest in the mountains and higher inland areas.

Major rivers of the region include the Los Angeles River, San Gabriel River, and Rio Hondo. The major creeks include the San Jose and Coyote Creeks. Other water bodies near or tributary to these streams are Big Dalton Wash; Puddingstone Wash and Reservoir; Legg Lake; and the Morris, Cogswell, Santa Fe, and San Gabriel Reservoirs. These water bodies are shown on Figure 2-4.

As shown in Figure 2-5, the major groundwater basins in the JOS service area include the Coastal Plain of Los Angeles, San Gabriel Valley, and Upper Santa Ana Valley Basins. Sub-basins within these major basins include the Central, West Coast, Raymond, Claremont Heights, Live Oak, Puente, Spadra, and Pomona Basins (Metropolitan Water District of Southern California [MWD] 2007). Groundwater is a significant source of water supply for some areas within the JOS, and the replenishment of coastal plain aquifers is vital to maintain the utility of these supplies. Imported water and recycled water are used to reduce water quality problems associated with groundwater overdraft and subsequent seawater intrusion.

Further description of the regional hydrology is provided in Chapter 11 of the Clearwater Program EIR/EIS, and a more extensive discussion of recycled water and other water resources is provided in Chapter 4 of this document.

2.1.7 Air Quality

The JOS service area lies completely within the South Coast Air Basin (SCAB), which is regulated by the South Coast Air Quality Management District (SCAQMD). The SCAB covers an area of approximately 6,745 square miles with a population of 14.6 million, and includes the metropolitan areas of Los Angeles, San Bernardino, and Riverside Counties, and all of Orange County as shown on Figure 2-6. It is bounded on the northwest by Ventura County and on the south by San Diego County. The northern boundary runs roughly along the Angeles National Forest, north of the ridge lines of the San Gabriel and San Bernardino Mountains. The eastern border runs north-south through the San Bernardino and San Jacinto Mountains.

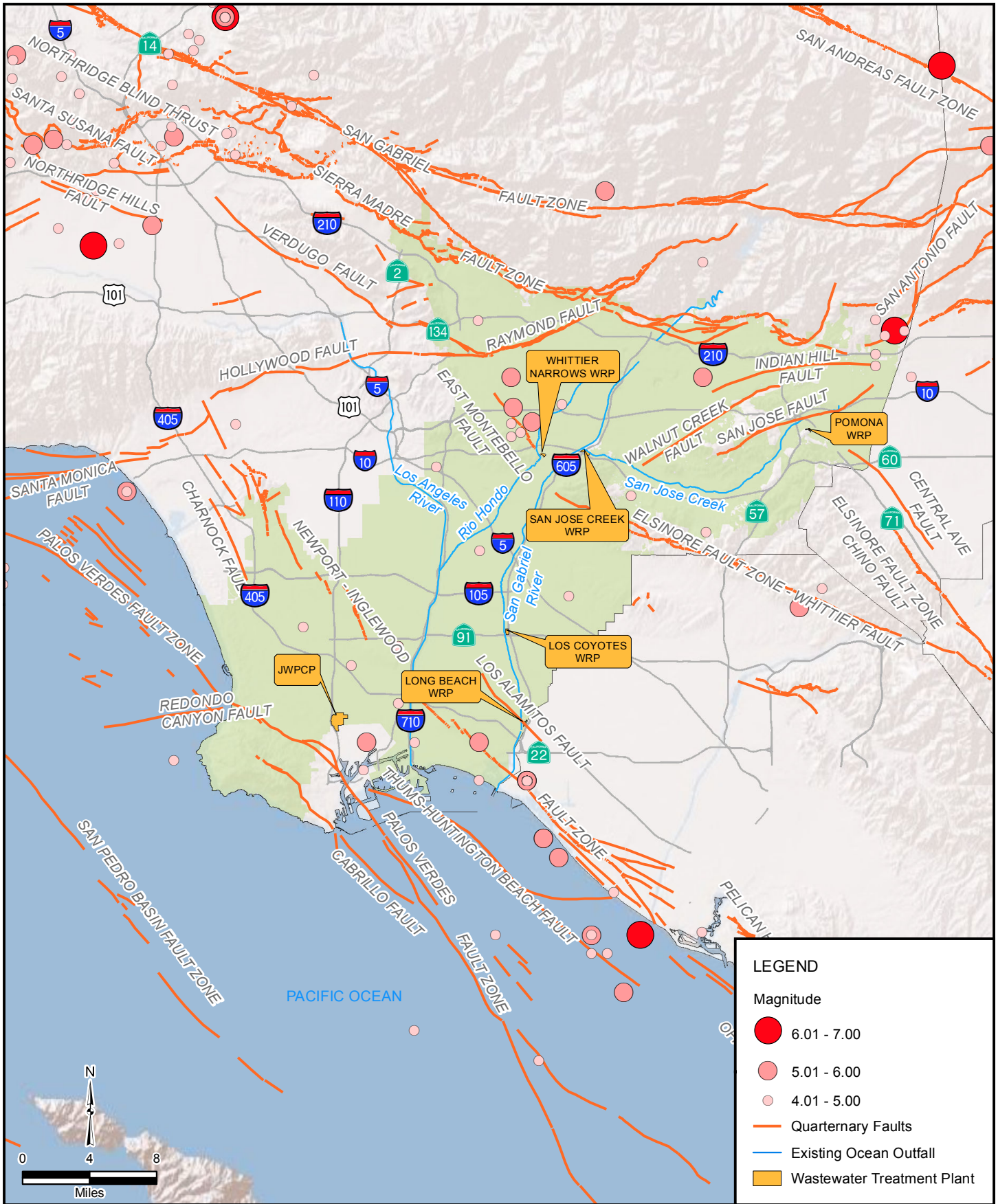
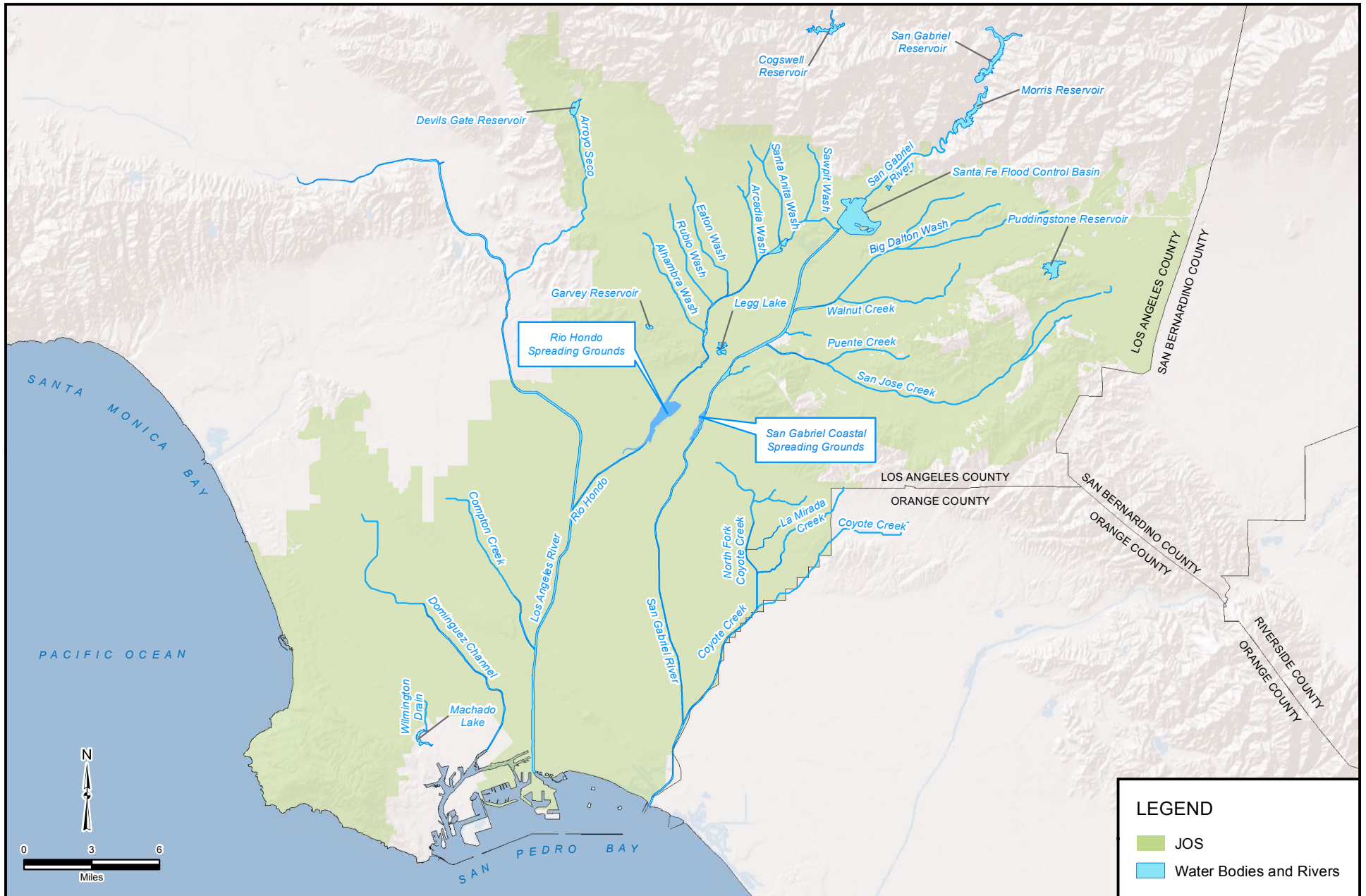

FIGURE 2-3



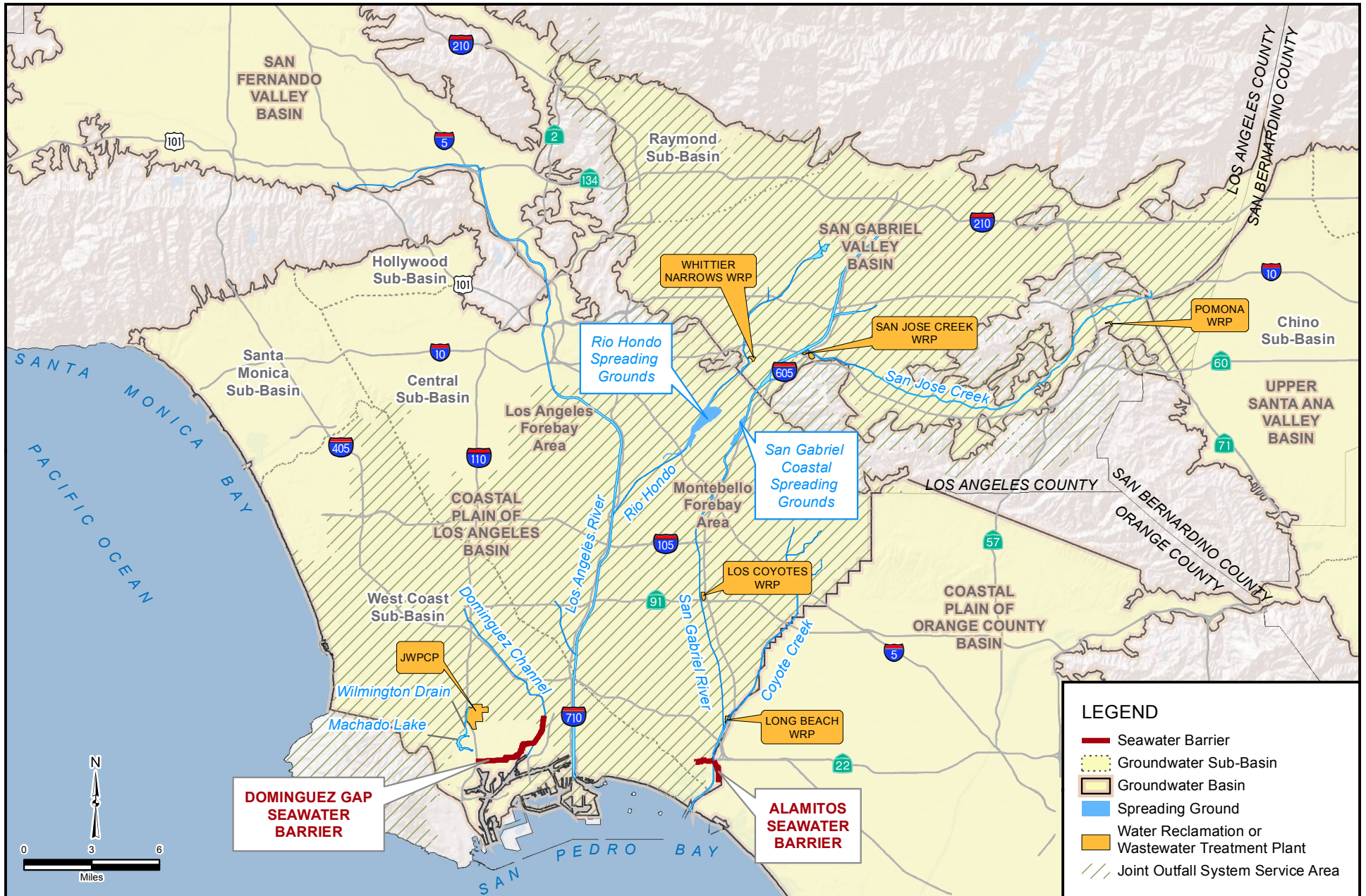



FIGURE 2-6

The Banning Pass area is excluded from the air basin. The western boundary is the entire shoreline of Los Angeles and Orange Counties.

The air quality in the SCAB has improved significantly over the last several decades. However, of the national ambient air quality standards (NAAQS) established for the six criteria pollutants (ozone, lead, sulfur dioxide, nitrogen dioxide, carbon monoxide, respirable particulate matter [PM₁₀], and fine particulate matter [PM_{2.5}]) and the additional four pollutants with state standards (sulfates, hydrogen sulfide, vinyl chloride, and visibility reducing particles), the SCAB is designated as a nonattainment area for federal and state standards for ozone and PM_{2.5}.

In addition to the NAAQS, greenhouse gas (GHG) regulations apply to the JOS service area. The California Global Warming Solutions Act of 2006 (also known as AB 32) established a comprehensive program of regulatory and market mechanisms to achieve reductions of GHGs. A scoping plan was adopted by the California Air Resources Board on December 12, 2008. The AB 32 scoping plan contains the main strategies that the state of California will use to reduce the GHGs that cause climate change. The scoping plan has a range of GHG reduction actions that include direct regulations, alternative compliance mechanisms, monetary and nonmonetary incentives, voluntary actions, market-based mechanisms such as a cap-and-trade system, and an AB 32 cost of implementation fee regulation to fund the program.

Further description of the regional air quality and GHGs is provided in Chapters 5 and 9, respectively, of the Clearwater Program EIR/EIS.

2.2 Demographics

A socioeconomic profile of the existing population, housing, income, and employment of the JOS service area and Los Angeles County is provided in this section. Projected growth for each JOS treatment plant drainage area is not addressed in this section, but will be discussed in Section 4.8. The analysis presented in this section is based on information provided by the U.S. Census, the Southern California Association of Governments (SCAG), and the California Department of Finance (DOF).

2.2.1 Population

In 1950, approximately 4.2 million people resided in Los Angeles County; by 2010, the population had more than doubled to approximately 9.8 million. This represents an increase of 5.6 million residents over 60 years, or an average growth rate of approximately 1 percent per year. In the last census decade (2000–2010), the population of the county grew by 300,000 (or 0.3 percent per year), which is approximately half the population increase of the previous decade. Approximately 50 to 52 percent of the county population resides within the JOS service area (based on a comparison of 1970 through 2010 population values). Population growth trends within the county and the JOS service area are shown in Table 2-3. Population growth trends within the JOS service area are also shown in Figure 2-7.

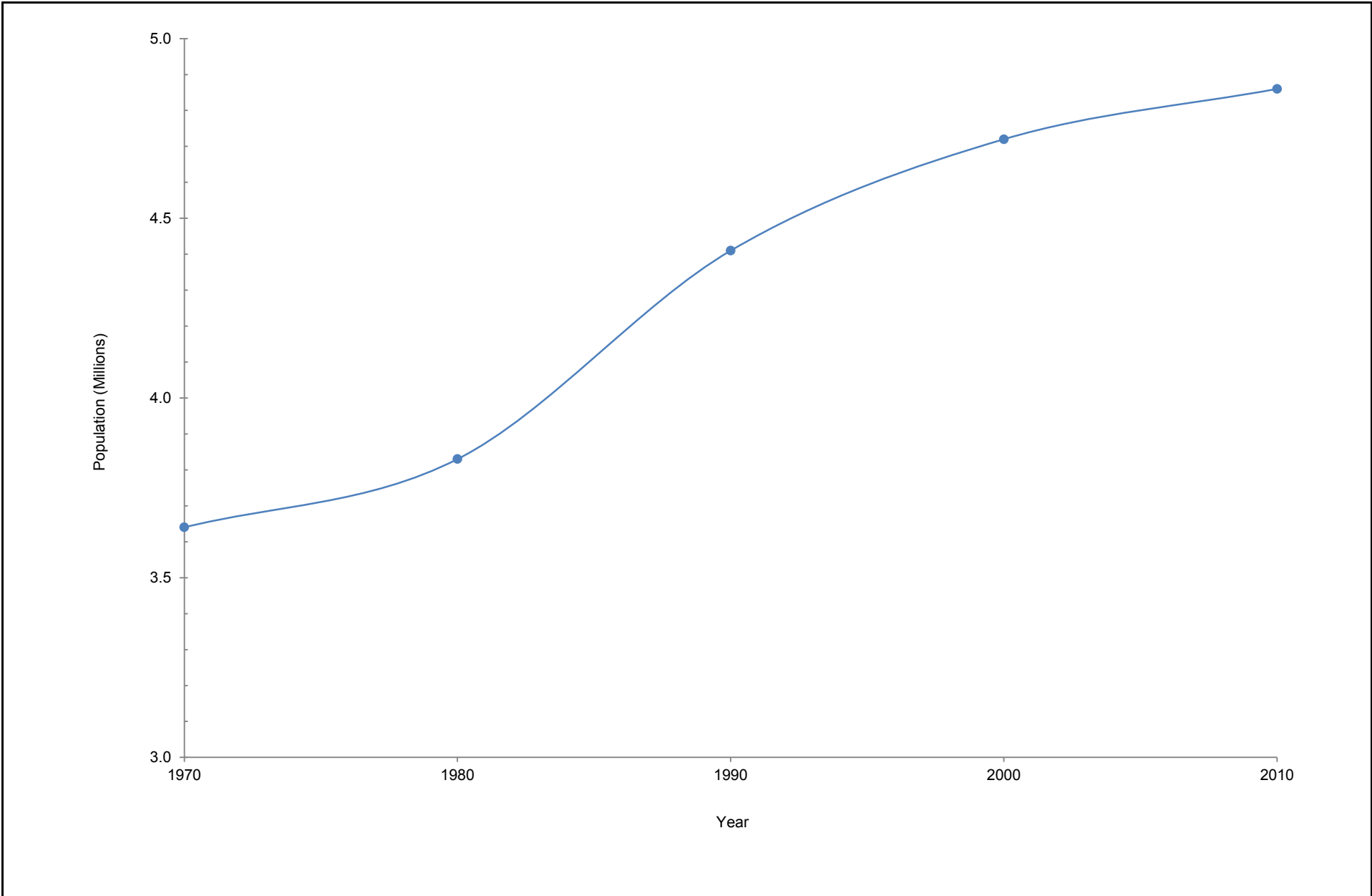

FIGURE 2-7

Population in the Joint Outfall System Service Area



Source: CA Department of Finance 2011

Table 2-3. Population in Los Angeles County and Joint Outfall System Service Area From 1970 to 2010

Year	Los Angeles County	JOS Service Area
1970	7,015,648	3,644,792 ^a
1980	7,473,757	3,827,742 ^a
1990	8,863,164	4,411,807 ^a
2000	9,519,484	4,720,505 ^a
2010	9,818,605 ^b	4,840,048 ^b

^a Population figures have been normalized to the 1990 census tract boundaries for 1970 through 2000 by DOF, which enabled decade-to-decade population comparison within the JOS Service area. Source: California Department of Finance Tract-to-Tract Comparability File 2009

^b Source: 2010 Census Summary File 1 prepared by the U.S. Census Bureau 2011

The racial and ethnic distributions within the JOS service area and Los Angeles County have changed significantly from 1970 through 2010. The distribution of population by race and ethnicity within Los Angeles County over this period is shown on Figure 2-8.

A significant shift in the predominant racial/ethnic group has occurred during the last 40 years. In 1970, 69 percent of the population in Los Angeles County was white and 19 percent was Hispanic. By 2010, the white percentage of the population had decreased to 19 percent, and the Hispanic percentage had increased to 53 percent. The numbers within the JOS service area are within a few percentage points of the county figures. The changes in both the JOS service area and Los Angeles County are summarized in Table 2-4.

Table 2-4. Ethnic and Racial Population Composition in Joint Outfall System Service Area and Los Angeles County From 1970 to 2010

Year	White		Black		Asian ^c		Hispanic		Other Non-Hispanic ^c	
	JOS	LA County	JOS	LA County	JOS	LA County	JOS	LA County	JOS	LA County
1970	69% ^a	68%	9% ^a	11%	NA	NA	19% ^a	18%	2% ^a	3%
1980	50% ^a	53%	12% ^a	12%	NA	NA	31% ^a	28%	7% ^a	7%
1990	35% ^a	41%	11% ^a	11%	NA	NA	41% ^a	38%	12% ^a	11%
2000	24% ^a	31%	10% ^a	9%	NA	NA	49% ^a	45%	17% ^a	15%
2010 ^b	19%	28%	9%	8%	16%	13%	53%	48%	3%	3%

^a Calculated by area-weighted GIS overlay analysis on 1990 census tracts. Source: California Department of Finance Tract-to-Tract Comparability File 2009

^b Source: 2010 Census Summary File 1 prepared by the U.S. Census Bureau 2011

^c Asian population composition is included in "Other Non-Hispanic" from 1970 to 2000.

NA = not available

2.2.2 Housing

Census data indicate that there were approximately 3.45 million dwelling units in Los Angeles County in 2010, and 1.56 million within the JOS service area. The total housing for the county and the JOS service area for 1970 through 2010 is presented in Table 2-5. In 2000, approximately 65.3 percent of housing within the JOS service area was single-family units. By comparison, countywide housing stock was approximately 56.1 percent single-family units.

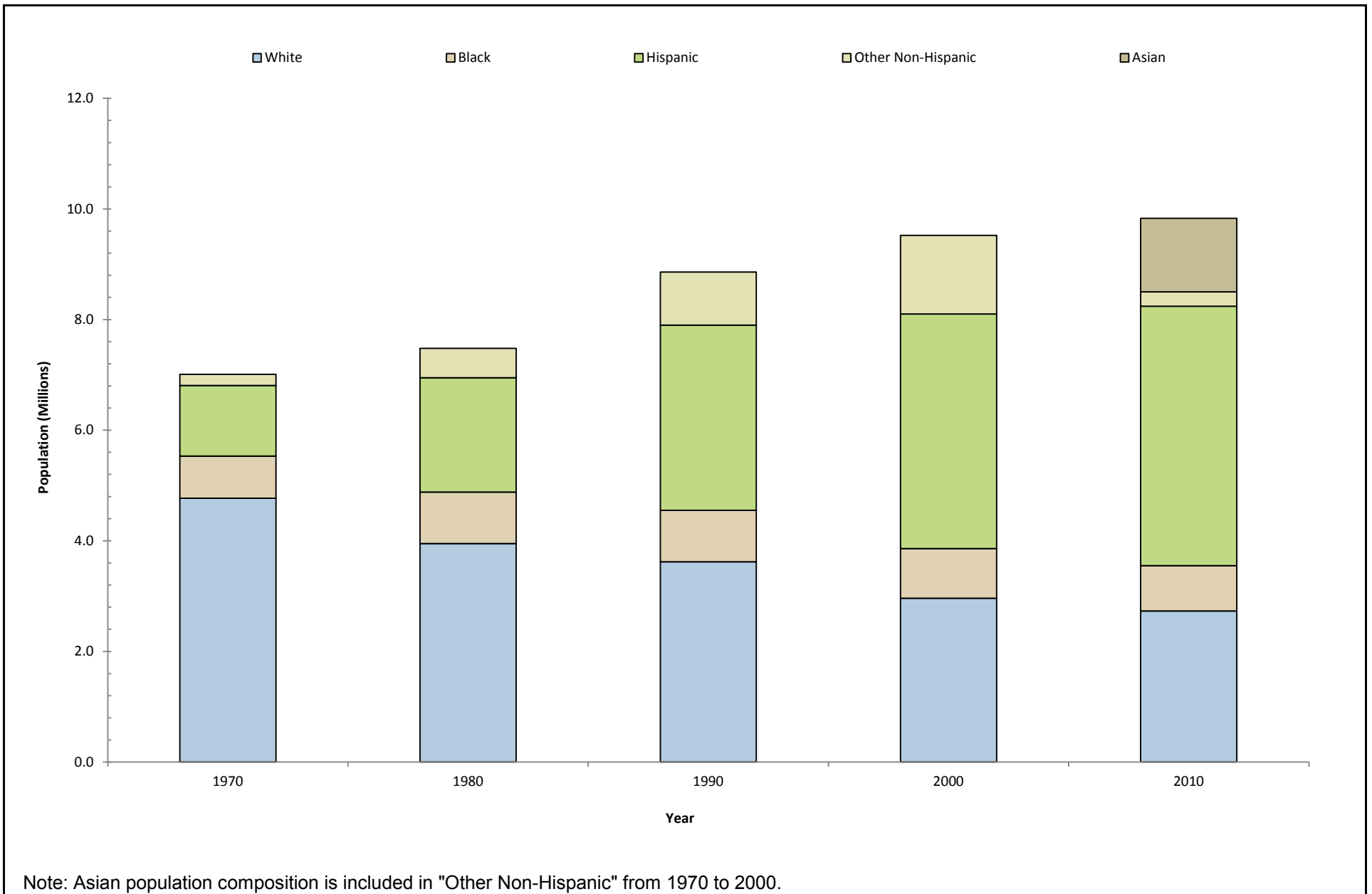

FIGURE 2-8



Distribution of Population by Race and Ethnicity in Los Angeles County

Source: 2010 Census Summary File 1, US Census Bureau 2011

Table 2-5. Dwelling Units in Joint Outfall System Service Area and Los Angeles County From 1970 to 2000

Year	Total Units		Single Family	
	JOS Service Area	LA County	JOS Service Area	LA County
1970	1,227,619	2,536,173	834,852	1,512,595
1980	1,361,217	2,852,770	876,727	1,604,290
1990	1,457,272	3,163,343	934,993	1,739,874
2000	1,487,929	3,270,963	971,037	1,835,134
2010 ^a	1,556,810	3,445,076	NA	NA

^a Source: 2010 Census Summary File 1 prepared by the U.S. Census Bureau 2011

NA = not available

Source: California Department of Finance Tract-to-Tract Comparability File 2009

Vacancy rates are defined as the percentage of unoccupied units in the total available housing stock. Low vacancy rates indicate that the housing market is constrained. According to Census data, the Los Angeles County vacancy rate of 5.9 percent indicates a relatively small housing shortage.

An increase in persons-per-household can indicate a shortage in housing or decreased housing affordability. The county vacancy rate and persons-per-household trends are shown in Table 2-6. The vacancy rate declined from 5.5 percent in 1990 to 4.2 percent in 2000 and then increased to 5.9 percent in 2010.

Table 2-6. Vacancy Rate and Persons per Household in Los Angeles County From 1980 to 2010

Year	Percent Vacancy	Persons per Household
1980	4.31%	2.620
1990	5.49%	2.802
2000	4.19%	2.910
2010	5.92%	2.850

Source: U.S. Census Bureau 2011

2.2.3 Income

According to the Census' 2005-2009 American Community Survey (ACS), the median household income was \$54,828 in Los Angeles County in 2009 and \$61,906 within the JOS service area. The median household income for the county and the JOS service area for 1970 through 2009 are presented in Table 2-7.

Table 2-7. Median Household Income in Joint Outfall System Service Area and Los Angeles County From 1970 to 2009

Year	Median Household Income	
	JOS Service Area	Los Angeles County
1970	\$9,641	\$9,740
1980	\$19,511	\$18,994
1990	\$38,565	\$37,980
2000	\$47,834	\$47,102
2009 ^a	\$61,906	\$54,828

^a Source: 2005-2009 American Community Survey prepared by the U.S. Census Bureau 2010

Source: California Department of Finance Tract-to-Tract Comparability File 2009

2.2.4 Employment

With an estimated Gross Regional Product (GRP) of approximately \$865 billion in 2007, the Southern California region (six-county SCAG region that includes Imperial, Los Angeles, Orange, Riverside, San Bernardino, and Ventura Counties) is considered one of the major centers of economic production in the world. The GRP of the Southern California economy ranks sixteenth in the world.

Employment is one of the major indicators of a region's economic health. Total employment figures for 1970 through 2009 for the SCAG region, Los Angeles County, and the JOS service area are shown in Table 2-8. Between 1990 and 2009, employment growth in the SCAG region was 14.0 percent based on the ACS and DOF estimates normalized to 1990 census tracts. In 2009, there were approximately 8.1 million jobs in the SCAG region, approximately 56 percent of which were located in Los Angeles County, and 44 percent of which were located in the JOS service area.

Most significantly, the DOF data show a decrease of 250,305 civilian jobs between 1990 and 2000 in Los Angeles County, 51 percent (128,560) of which were in the JOS service area. The Los Angeles County unemployment rate has fluctuated generally between 6 percent and 10 percent since 1990, with only a brief drop below 5 percent in 2006/2007. By 2010, the unemployment rate had increased to 12.7 percent.

Table 2-8. Civilian Jobs in the Southern California Association of Governments Region, Los Angeles County, and the Joint Outfall System Service Area From 1970 to 2009

Year	SCAG Region	Los Angeles County	JOS Service Area
1970	3,903,722	2,824,789	1,418,923
1980	5,315,413	3,470,076	1,717,768
1990	6,949,076	4,203,792	2,018,271
2000	6,948,813	3,953,487	1,889,711
2009 ^a	8,082,681	4,522,378	2,179,888

^a Source: 2005-2009 American Community Survey prepared by the U.S. Census Bureau 2010

Source: California Department of Finance Tract-to-Tract Comparability File 2009

The 2000 and 2009 jobs-to-housing ratios for the JOS service area are 1.27 and 1.40, respectively, as compared to 1.21 and 1.31 for the entire county for the same respective years. There were more jobs per household in 2009 than in 2000 both in the JOS service area and in the county in general.

Chapter 3

LAWS AND REGULATIONS

3.1 Introduction

The collection and treatment of wastewater and the management of treated wastewater effluent is subject to federal, state, and local regulations. Furthermore, federal and state funding for capital projects is contingent upon the fulfillment of additional regulatory requirements. A broad summary of federal, state, and local laws, regulations, and plans that must be considered when planning for wastewater treatment and effluent management facilities is provided in this chapter.

3.2 Regulations for Federal and State Waters

This section discusses regulations pertaining to federal and state waters that typically impact publicly owned treatment works (POTWs). The Joint Outfall System (JOS) is subject to the federal regulations listed in Section 3.2.1 because it discharges to waters of the United States (U.S.).

3.2.1 Federal Regulations

3.2.1.1 Refuse Act

Federal regulation of discharges to bodies of water began in 1899 with the passage of the Refuse Act, which was primarily intended to protect navigation by preventing discharges that might interfere with the use of the nation's waterways as transportation corridors.

3.2.1.2 Water Pollution Control Act

The Water Pollution Control Act of 1948 was the first federal legislation to address water quality, which had been historically regulated on state and local levels. This act reaffirmed that water pollution control was primarily a state responsibility, but it also provided the federal government with the authority to conduct investigations, research, and surveys. In 1956, the Water Pollution Control Act was amended to include provisions for federal grants to support the construction of POTWs and direct federal regulation of waste discharges.

3.2.1.3 Water Quality Control Act

The Water Quality Control Act, enacted in 1965, required states to establish federally approved ambient water quality standards for interstate water courses and to develop federally approved implementation plans for controlling pollution sufficiently to meet these standards.

3.2.1.4 Clean Water Act

The 1972 amendments to the federal Water Pollution Control Act marked the beginning of the current system of federal water quality regulation and increased the level of federal grant funding for municipal

wastewater treatment facilities. Goals of the 1972 amendments included the elimination of discharges of pollutants to navigable waters of the U.S. by 1985 and, wherever attainable, the protection of fishable and swimmable waters by 1983. The 1972 amendments initiated the National Pollutant Discharge Elimination System (NPDES) permit program, which required the issuance of discharge permits for all municipal and industrial point sources that discharge into waters of the U.S.

The 1972 amendments preserved the system of state-established water quality criteria promulgated under the 1965 Water Quality Act, but the states were additionally required to review and update these standards every 3 years and to submit revisions to the U.S. Environmental Protection Agency (EPA) for approval. These amendments required the establishment of water quality standards, consisting of the designated uses of the navigable waters and the water quality criteria for such waters. The standards and criteria must take into consideration the water source's use and value for public water supplies; propagation of fish and wildlife; and recreational, agricultural, industrial, navigation, and other purposes. Where compliance with identified technology-based standards was not sufficient to ensure attainment of approved water quality standards, the 1972 amendments directed the permitting agency to administer water quality-based effluent limitations in permits.

The federal Water Pollution Control Act was amended a third time in 1977, and the amended act was renamed the Clean Water Act (CWA). The 1977 amendments extended some of the deadlines identified in 1972 and more clearly delineated the manner in which conventional and toxic water pollutants were to be treated. The 1977 CWA required that toxic pollutants be managed, either through the effluent guidelines program for major industrial dischargers or through the pretreatment program for specified industries discharging to POTWs.

The 1987 amendments to the CWA (1) ended the construction grant program and replaced it with the State Revolving Fund (SRF) loan program for the construction of municipal sewerage facilities, (2) required the states to promulgate water quality standards for toxic water pollutants for which advisory water quality criteria had been developed pursuant to Section 304(a) of the CWA, and (3) established new requirements for the states to develop and implement programs to control non-point source pollution. To address non-point source pollution, the 1987 amendments also required the issuance of NPDES permits for storm water discharges associated with municipal, industrial, and construction activities.

3.2.1.5 National Pretreatment Program

The National Pretreatment Program, established through the CWA in 40 Code of Federal Regulations (CFR) Part 403, requires implementation of pretreatment programs for POTWs with capacities greater than 5 million gallons per day (MGD) that receive pollutants from industrial sources that may interfere with POTW operations. POTWs are required to prohibit or limit discharges of pollutants from industrial facilities that could pass through the treatment processes into receiving waters, interfere with treatment plant operations, or limit biosolids management options. Smaller POTWs with significant industrial influent, treatment process problems, or violations of effluent limitations are also required to implement pretreatment programs. In addition, federal standards have been established to regulate sewer discharges from specific types of industries.

POTWs are responsible for developing, implementing, and enforcing their own pretreatment programs. If POTWs fail to properly administer pretreatment programs, they are subject to oversight by state and federal regulatory agencies and may be subjected to enforcement actions, penalties, fines, or other remedies provided for by the CWA.

The Sanitation Districts of Los Angeles County (Sanitation Districts) developed and implemented an industrial wastewater pretreatment program in 1972 with the adoption of the Wastewater Ordinance. Local discharge limits for industrial wastewater dischargers were adopted in 1975, and the EPA approved the Sanitation Districts' program in March 1985. Local industrial wastewater discharge limits were established to ensure compliance with NPDES and waste discharge requirements (WDRs) permit limits for each treatment plant, as well as to protect treatment plant operations and biosolids quality. The pretreatment program has been very successful in reducing the discharge of contaminants.

The existing industrial wastewater discharge limits are presented in Table 3-1. The Sanitation Districts regularly review these limits to determine if modifications are needed. Modifications to the discharge limits may be made if determined necessary in order to maintain biosolids quality and/or meet NPDES and WDR permit limits.

Table 3-1. Industrial Wastewater Discharge Limits

Constituent	Instantaneous Maximum Limit (mg/L)
Arsenic	3
Zinc	25
Cadmium	15
Chromium (Total)	10
Copper	15
Cyanide (Total)	10
Lead	40
Mercury	2
Nickel	12
Silver	5
TICH ^a	Essentially None ^b

^a Total Identifiable Chlorinated Hydrocarbons (TICH) consists of aldrin, dieldrin, chlordane (cis & trans), trans-nonachlor, oxychlordane, heptachlor, heptachlor epoxide, hexachlorocyclohexane (alpha-, beta-, delta-, and gamma- isomers), toxaphene, polychlorinated biphenyls, and pp' and op' isomers of dichlorodiphenyltrichloroethane (DDT), dichlorodiphenyldichloroethane (DDD), and dichlorodiphenyldichloroethylene (DDE).

^b TICH must be maintained below detection limits.

mg/L = milligrams per liter

In addition, the following numerical requirements from the Sanitation Districts' Wastewater Ordinance apply:

- The pH of the wastewater discharged shall not be below 6.0 at any time
- The dissolved sulfide concentration of the wastewater shall not exceed 0.1 milligrams per liter (mg/L) at any time
- The temperature of the wastewater shall not exceed 140 degrees Fahrenheit (°F) at any time, and shall not cause the wastewater influent to a Sanitation Districts' treatment plant to exceed 104°F

3.2.1.6 National Toxics Rule and California Toxics Rule

The National Toxics Rule (NTR) and the California Toxics Rule (CTR) contain regulatory criteria adopted pursuant to Section 303(c) of the CWA that apply to inland surface waters and enclosed bays and estuaries in California that are waters of the U.S. In 1992, the EPA promulgated priority toxic pollutant water quality criteria for select constituents for California in the NTR. The EPA promulgated the CTR in response to litigation that overturned the Inland Surface Waters Plan (ISWP) (see Section 3.2.2.2) and the Enclosed Bays and Estuaries Plan (two statewide water quality control plans) in 1994. The CTR took

effect in May 2000 and established numeric criteria for the remaining priority toxic pollutants required under Section 303(c)(2)(B) of the CWA. The NTR and CTR include criteria for the protection of aquatic life and human health. In translating these criteria to effluent limitations in permits, California Regional Water Quality Control Boards (RWQCBs) determine which designated beneficial uses apply to the receiving waters and base the permit limits on the most stringent applicable criteria.

3.2.1.7 Section 404 and Section 401 Permits

Section 404 of the CWA established a permit program for regulation of the discharge of dredged material or fill into waters of the U.S. The permit program is administered by the Secretary of the Army, acting through the U.S. Army Corps of Engineers (Corps). Section 404 authorizes the EPA to regulate the discharge of any dredged material or fill that can cause adverse effects on municipal water supplies, recreational areas, wildlife, fisheries, or shellfish beds.

Section 401 of the CWA provides the states with the authority to regulate hydrologic modification projects that require Section 404 permits. In California, the RWQCBs oversee the 401 Water Quality Certification process.

3.2.2 State Regulations

3.2.2.1 The Porter-Cologne Water Quality Control Act

The Porter-Cologne Water Quality Control Act of 1969 (PCA) established the current legal framework for water quality regulation in California. The PCA requires the State Water Resources Control Board (SWRCB) to adopt water quality control plans and policies for the protection of water quality. The SWRCB is the primary agency responsible for formulating policies to protect surface waters and groundwater supplies within the state of California. The PCA also established nine RWQCBs to develop and implement water quality protection programs at the local level.

The SWRCB has delegated authority for the day-to-day administration and enforcement of the PCA to the regional level. Each RWQCB develops regional water quality control plans (basin plans) that identify important water resources within its region and specify the beneficial uses for each of these resources. A basin plan must:

- Identify the beneficial uses of the waters to be protected
- Establish water quality objectives for the reasonable protection of those beneficial uses
- Establish an implementation program for achieving water quality objectives

Each basin plan must be approved by the SWRCB, the Office of Administrative Law, and the EPA. Basin plans are scheduled for updates on a 3-year (triennial) cycle.

The Sanitation Districts' JOS facilities are under the jurisdiction of the Los Angeles Regional Water Quality Control Board (LARWQCB) and are regulated under the regional basin plan known as the Water Quality Control Plan, Los Angeles Region (Basin Plan). The LARWQCB is also responsible for administering and enforcing NPDES permits, WDRs, and pretreatment programs within the Los Angeles Region.

The PCA authorizes RWQCBs to regulate all discharges to water and/or land in order to protect water quality. RWQCBs issue WDRs to all dischargers in accordance with Section 13263 of the California Water Code (CWC) and are authorized to review WDRs periodically. Authority delegated to RWQCBs

includes the issuance of WDRs, review of self-monitoring reports submitted by dischargers, performance of independent compliance checks, and execution of enforcement actions. Enforcement actions, which may be taken by RWQCBs under the authority provided by the PCA, range from orders requiring relatively simple corrective actions to monetary penalties levied for failure to comply with permit provisions.

The RWQCBs have also been delegated responsibilities associated with administering and enforcing the provisions of the CWA. When discharges are made to waters of the U.S., NPDES permits for point source discharges are issued. Under Chapter 5.5 of the PCA, WDRs are deemed equivalent to NPDES permits issued under the CWA. Thus, NPDES permits are generally issued as both federal and state permits in California and are generally assigned both a state order number and an NPDES permit number.

3.2.2.2 Statewide Implementation Policy

In 1991, the SWRCB adopted the ISWP in fulfillment of the requirements of Section 303 of the CWA. The ISWP contained narrative and numeric water quality objectives for toxic pollutants, as well as chronic and acute toxicity objectives and provisions for implementation. Pursuant to the CWA, the SWRCB submitted the ISWP to the EPA for review and approval. In November 1991, the EPA took action on the ISWP, which included disapproval of performance goals for categorical water bodies (e.g., effluent-dependent water bodies). Furthermore, in 1991, a lawsuit was filed against the SWRCB regarding the compliance of ISWP with three state laws. This litigation was resolved with the invalidation of the ISWP in March 1994 by the Sacramento County Superior Court and the subsequent rescission of the ISWP by the SWRCB.

In March 2000, the SWRCB adopted a policy establishing provisions to implement the priority toxic pollutant criteria in the CTR and NTR and priority pollutant objectives in the basin plans of each RWQCB. The Policy for Implementation of Toxics Standards for Inland Surface Waters, Enclosed Bays, and Estuaries of California (also known as the Statewide Implementation Policy) establishes provisions for translating CTR criteria, NTR criteria, and basin plan water quality objectives for toxic pollutants into:

- NPDES permit effluent limits
- Compliance determinations
- Monitoring for 2, 3, 7, 8-tetrachlorodibenzo-p-dioxin equivalents
- Chronic toxicity control
- Initiating site-specific objective development
- Granting exceptions

For the NTR and the priority pollutant water quality objectives in basin plans, the policy took effect on April 28, 2000. For the CTR, the policy took effect on May 18, 2000.

3.2.3 Local Regulations

3.2.3.1 Water Quality Control Plan for the Los Angeles Basin

The Basin Plan provides the basis for the regulatory program of the LARWQCB. It sets forth water quality objectives for all surface and groundwaters within the basin. The Basin Plan designates beneficial uses for all such waters and specifies narrative and numerical water quality objectives that must be maintained or attained to protect those uses. The Basin Plan also identifies general types of water quality

problems that can threaten beneficial uses of water resources in the Los Angeles region and identifies required or recommended control measures for these problems, including any Total Maximum Daily Loads (TMDLs) that have been established to improve the quality of impaired water bodies. The Basin Plan also summarizes applicable provisions of SWRCB and RWQCB planning and policy documents, as well as water quality management plans adopted by other federal, state, and regional agencies. In addition, past and present water quality monitoring programs are summarized. LARWQCB orders are based on applicable water quality objectives and/or prohibitions specified in the Basin Plan.

3.3 Discharge Regulations for JOS Plants

Five of the six water reclamation plants (WRPs) in the JOS and the Joint Water Pollution Control Plant (JWPCP) hold NPDES permits that must be renewed every 5 years. The WRPs include the Pomona Water Reclamation Plant (POWRP), the San Jose Creek Water Reclamation Plant (SJCWRP), the Whittier Narrows Water Reclamation Plant (WNWRP), the Los Coyotes Water Reclamation Plant (LCWRP), and the Long Beach Water Reclamation Plant (LBWRP). The sixth WRP, the La Cañada Water Reclamation Plant (LACAWRP), does not have an NPDES permit because the entire plant effluent is reused at a golf course; no effluent is discharged to waters of the U.S.

The NPDES permits for the WRPs contain limits that are consistent with specific receiving water quality objectives (WQOs) of the Los Angeles Basin and the Statewide Implementation Policy. In addition to NPDES permits, all the WRPs have water reclamation requirements (WRRs), and the POWRP, SJCWRP, and WNWRP are regulated under the Montebello Forebay Groundwater Recharge Permit. The WRRs for the WRPs contain limits consistent with specific water quality objectives for hydrologic subareas in the Basin Plan.

The primary purpose of the limitations, prohibitions, and provisions in the JWPCP NPDES permit is to implement the objectives of the SWRCB's Water Quality Control Plan for Ocean Waters of California, which was designed to maintain the indigenous marine life and a healthy and diverse marine community.

The current permit and order numbers for the JOS wastewater treatment plants are summarized in Table 3-2.

Table 3-2. Permit and Order Numbers for JOS Plants

Plant	Effluent Discharge			
	NPDES Permit Number	LARWQCB Order Number	LARWQCB Order Number (Reuse)	LARWQCB Order Number (Recharge)
POWRP	CA0053619	R4-2009-0076	81-34, 97-072	91-100, R4-2009-0048
SJCWRP	CA0053911	R4-2009-0078	87-50, 97-072	91-100, R4-2009-0048
WNWRP	CA0053716	R4-2009-0077	88-107, 97-072	91-100, R4-2009-0048
LCWRP	CA0054011	R4-2007-0048	87-51, 97-072	N/A
LBWRP	CA0054119	R4-2007-0047	87-47, 97-072	N/A
LACAWRP	N/A	N/A	00-99	N/A
JWPCP	CA0053813	R4-2011-0151	N/A	N/A

N/A = not applicable

Adoption years for LARWQCB permits are reflected in the first two digits of the order numbers for the permits adopted before 2002 and in the middle four digits of newer permits. Requirements and numerical limits for the JWPCP and the WRPs are summarized in the following sections.

3.3.1 WRP Requirements

All of the JOS WRPs, except the LACAWRP, provide tertiary treatment to influent wastewater. Treatment at these WRPs currently consists of primary sedimentation, activated sludge treatment, coagulation, filtration, chlorination, and dechlorination. With the exception of the LACAWRP, all of the WRPs have been recently upgraded to include nitrification and denitrification.

3.3.1.1 NPDES Requirements

The NPDES permit final effluent limits for conventional and non-conventional constituents are listed in Table 3-3. The permits also contain limits for total coliform bacteria, turbidity, radioactivity, and toxicity. In addition to effluent limits, the WRP NPDES permits contain narrative and numeric receiving water limits for chemical, physical, and biological parameters that are designed to protect the quality of the receiving waters and beneficial uses, and state that pollutants must not be present in wastes discharged at concentrations that pose a threat to groundwater quality.

Total Coliform Limits

The NPDES permits for all WRPs require discharges to be adequately disinfected. To meet this requirement, the effluent must be sampled and tested for total coliform bacteria. The median number of total coliform bacteria for the last 7 days of samples cannot exceed a most probable number (MPN) or Coliform Forming Units (CFU) of 2.2 per 100 milliliters (mL). Additionally, the number of total coliform bacteria cannot exceed an MPN or CFU of 23 per 100 mL in more than one sample during a 30-day period. Additionally, at the POWRP, the number of total coliform bacteria must not exceed an MPN or CFU of 240 per 100 mL in any sample.

Turbidity

For the protection of the water contact recreation beneficial uses, turbidity, which measures the cloudiness or haziness of a fluid caused by suspended solids, must be monitored. WRP NPDES permits have limits of (1) a daily (or 24-hour) average of 2 nephelometric turbidity units (NTUs), (2) a limit of 5 NTUs that cannot be exceeded more than 5 percent of the time (72 minutes) during any 24-hour period, and (3) a maximum of 10 NTUs at any time.

Radioactivity

For the POWRP, SJCWRP, and WNWRP, the NPDES permits require that radioactivity must not exceed the limits specified in Title 22, Chapter 15, Article 5, Section 64443, of the California Code of Regulations (CCR). For the LBWRP and LCWRP, the NPDES permits require that radionuclides will not be present in concentrations that are deleterious to human, plant, animal, or aquatic life or that result in accumulation of radionuclides in the food web to an extent that presents a hazard to human, plant, animal, or aquatic life.

Toxicity

Toxicity requirements were developed for both acute and chronic toxicity. The requirements apply to all of the WRPs. The acute toxicity of the effluent must be such that (1) the average survival in the undiluted effluent for any three consecutive bioassay tests must be at least 90 percent and (2) no single test produces less than 70 percent survival. Noncompliance with these requirements triggers accelerated monitoring and, as necessary, implementation of a Toxicity Identification Evaluation and a Toxicity Reduction Evaluation Workplan.

Table 3-3. NPDES Permit Final Effluent Limits for Conventional and Non-Conventional Constituents for WRP Discharges

Constituents	Units	POWRP ^a			SJCWRP ^b			WNWRP ^c			LCWRP ^d			LBWRP ^e		
		AM	AW	MD	AM	AW	MD	AM	AW	MD	AM	AW	MD	AM	AW	MD
BOD (5-day @ 20°C)	mg/L	20 ^f	30 ^f	45 ^f	20 ^f	30 ^f	45 ^f	20 ^f	30 ^f	45 ^f	20 ^f	30 ^f	45 ^f	20 ^f	30 ^f	45 ^f
TSS	mg/L	15 ^f	40 ^f	45 ^f	15 ^f	40 ^f	45 ^f	15 ^f	40 ^f	45 ^f	15 ^f	40 ^f	45 ^f	15 ^f	40 ^f	45 ^f
pH	standard units	6.5 ^g	-	8.5 ^g	6.5 ^g	-	8.5 ^g	6.5 ^g	-	8.5 ^g	6.5 ^g	-	8.5 ^g	6.5 ^g	-	8.5 ^g
Oil and Grease	mg/L	10 ^f	-	15 ^f	10 ^f	-	15 ^f	10 ^f	-	15 ^f	10 ^f	-	15 ^f	10 ^f	-	15 ^f
Settleable Solids	mL/L	0.1	-	0.3	0.1	-	0.3	0.1	-	0.3	0.1	-	0.3	0.1	-	0.3
Total Residual Chlorine	mg/L	-	-	0.1	-	-	0.1 ^f	-	-	0.1 ^f	-	-	0.1	-	-	0.1 ^f
TDS	mg/L	750 ^f	-	-	750 ^f	-	-	750 ^f	-	-	-	-	-	-	-	-
Ammonia Nitrogen	mg/L	^{f,h}	-	^{f,h}	^{f,i}	-	^{f,i}	^{f,i}	-	^{f,i}	2.1 ^f	-	4.9 ^f	1.8 ^f	-	4.2 ^f
Chloride	mg/L	180 ^f	-	-	180 ^f	-	-	180 ^f	-	-	-	-	-	-	-	-
Sulfate	mg/L	300 ^f	-	-	300 ^f	-	-	300 ^f	-	-	-	-	-	-	-	-
Boron	mg/L	1 ^f	-	-	1 ^f	-	-	1 ^f	-	-	-	-	-	-	-	-
Detergents (as MBAS)	mg/L	0.5 ^f	-	-	0.5 ^f	-	-	0.5 ^f	-	-	-	-	-	-	-	-
Nitrate + Nitrite (as N)	mg/L	8 ^f	-	-	8 ^f	-	-	8 ^f	-	-	8 ^f	-	-	8 ^f	-	-
Nitrate (as N)	mg/L	-	-	-	-	-	-	8 ^f	-	-	-	-	-	-	-	-
Nitrite-N (as N)	mg/L	1 ^f	-	-	1 ^f	-	-	1 ^f	-	-	1 ^f	-	-	1 ^f	-	-
Temperature	°F	-	-	86 ^j	-	-	86 ^j	-	-	86 ^j	-	-	86 ^j	-	-	86 ^j
Removal of BOD and TSS	%	≥ 85	-	-	≥ 85	-	-	≥ 85	-	-	≥ 85	-	-	≥ 85	-	-

^a Permit also contains effluent limits for bis(2-ethylhexyl)phthalate, lead, selenium, and total trihalomethanes.

^b Permit also contains effluent limits for copper, lead, and selenium.

^c Permit also contains effluent limits for cadmium, copper, lead, mercury, and zinc.

^d Permit also contains effluent limits for copper and cyanide.

^e Permit also contains effluent limits for 4,4'-DDE, copper, lead, and zinc.

^f Permit also contains a corresponding mass limit established using the WRP design flow.

^g Limits are for instantaneous minimum and instantaneous maximum rather than average monthly and maximum daily.

^h Seasonally adjusted limits apply.

ⁱ Different limits apply to each discharge point.

^j Unless caused by external ambient temperature.

AM = average monthly

AW = average weekly

MD = maximum daily

BOD = biochemical (or biological) oxygen demand

mL/L = milliliter per liter

mg/L = milligram per liter

TSS = total suspended solids

TDS = total dissolved solids

MBAS = methylene blue active substances

N = nitrogen

pH = hydrogen ion concentration

There must not be any chronic toxicity in the effluent discharge. A monthly median greater than 1 chronic toxicity unit (TUc) will trigger accelerated monitoring and, as necessary, implementation of a Toxicity Identification Evaluation and a Toxicity Reduction Evaluation Workplan.

3.3.1.2 Reuse Requirements

Reuse permit limits from the Montebello Forebay recharge permit and the limits for standard permissible uses of recycled water are listed in Table 3-4. The permits also contain limits for total coliform bacteria, turbidity, radioactivity, and constituents with drinking water standards, as well as a number of narrative restrictions. The recharge permit applies to effluent discharged from the POWRP, SJCWRP, and WNWRP to the Rio Hondo or San Gabriel Coastal Spreading Grounds.

Table 3-4. WRP Recharge and Reuse Permit Limits

Constituent	Units	Montebello Forebay Recharge Permit	LBWRP Reuse Permit	LCWRP Reuse Permit	POWRP Reuse Permit	SJCWRP Reuse Permit	WNWRP Reuse Permit	LACAWRP Reuse Permit
TDS	mg/L	700 ^a	1,000 ^a	1,000 ^a	750 ^a	800 ^a	600 ^a	1,150 ^b
Suspended Solids	mg/L	15 ^c	-	-	-	-	15 ^c	30 ^b
Settleable Solids	mL/L	0.1 ^d	-	-	-	-	0.1 ^d	-
Nitrate + Nitrite Nitrogen	mg/L	10 ^b	-	-	-	-	10 ^b	-
Sulfate	mg/L	250 ^a	250 ^a	250 ^a	300 ^a	250 ^a	150 ^a	375 ^b
Chloride	mg/L	250 ^a	250 ^a	250 ^a	150 ^a	250 ^a	100 ^a	250 ^b
Fluoride	mg/L	1.6 ^a	-	-	-	-	1.6 ^a	-
Boron	mg/L	1 ^a	1.5 ^a	1.5 ^a	1 ^a	1.5 ^a	0.5 ^a	1 ^b
Oil and Grease	mg/L	10 ^f	-	-	-	-	10 ^f	-
pH	standard units	6.0/9.0 ^g	6.0/9.0 ^g	6.0/9.0 ^g	6.0/9.0 ^g	6.0/9.0 ^g	6.0/9.0 ^g	6.0/9.0 ^g
Temperature	°F	100	-	-	-	-	-	-
BOD (5-day @ 20°C)	mg/L	-	-	-	-	-	20 ^e	30 ^b

^a Maximum daily limit.

^b Average monthly limit.

^c Limits for suspended solids are: 30-day average, 15 mg/L; 7-day average, 40 mg/L.

^d Limits for settleable solids are: 30-day average, 0.1 mL/L; daily maximum, 0.3 mL/L.

^e Limits for BOD₅ are: 30-day average, 20 mg/L; 7-day average, 30 mg/L.

^f Oil and grease limits are: 30-day average, 10 mg/L; daily maximum, 15 mg/L.

^g pH must be between 6.0 and 9.0 at all times.

mg/L = milligram per liter

mL/L = milliliters per liter

BOD = biochemical (or biological) oxygen demand

pH = hydrogen ion concentration

TDS = total dissolved solids

Total Coliform Limits

The reuse permits require discharges to be adequately disinfected. To ensure that this requirement is met, the effluent must be sampled and tested for total coliform bacteria. The median number of total coliform bacteria for the last 7 days of samples cannot exceed a MPN or CFU of 2.2 per 100 mL. Additionally, the

number of total coliform bacteria cannot exceed an MPN or CFU of 23 per 100 mL in more than one sample during a 30-day period.

Turbidity

To ensure that recycled water has been adequately filtered, turbidity, which measures the cloudiness or haziness of a fluid caused by suspended solids, must be monitored. WRP reuse permits have limits of (1) a daily (or 24-hour) average of 2 NTUs, and (2) a limit of 5 NTUs that cannot be exceeded more than 5 percent of the time (72 minutes) during any 24-hour period.

Radioactivity

For the LBWRP, LCWRP, POWRP, SJCWRP, WNWRP, and LACAWRP, the reuse permits require that radioactivity must not exceed the limits specified in Title 22, Chapter 15, Article 5, Sections 64441 and 64443, of the CCR.

Drinking Water Standards

The LBWRP, LCWRP, SJCWRP, and WNWRP reuse permits and the POWRP, SJCWRP, and WNWRP recharge permits require that recycled water must not contain trace constituents in concentrations exceeding limits contained in California drinking water standards. The Montebello Forebay recharge permit additionally requires that drinking water action levels (now called notification levels) be met as well. For the POWRP, the reuse permit requires that recycled water must not contain heavy metals, arsenic, or cyanide in concentrations exceeding California drinking water standards.

3.3.1.3 Discharge Points and Receiving Waters

Pomona WRP

Almost all of the recycled water from the POWRP is reused either directly via a distribution system or indirectly through groundwater recharge. The recycled water is supplied to the city of Pomona, California State Polytechnic University, Walnut Valley Water District, and the Sanitation Districts' Spadra Landfill site. Uses of recycled water from the POWRP include landscape and food crop irrigation, fire protection, dust control, cooling tower supply, and concrete mixing. Recycled water that is not directly reused is released into the South Fork of San Jose Creek (Discharge Point 001), which flows into the San Gabriel River and then can be diverted into the Rio Hondo or San Gabriel Coastal Spreading Grounds. Sections of San Jose Creek, and the section of the San Gabriel River into which San Jose Creek flows, are unlined, which allows percolation of recycled water into the groundwater during downstream travel.

San Jose Creek WRP

The SJCWRP consists of the East and West plants, two independently operated units with separate influent sources and effluent outfalls. Almost all of the recycled water from SJCWRP is reused. Groundwater recharge is the largest beneficial use of the plant's effluent. Recycled water from the SJCWRP is also used for landscape irrigation and at reuse sites through the city of Industry's distribution system. Recycled water that is not directly reused is released into the San Gabriel River or San Jose Creek at several discharge points. The discharge points are as follows:

- 001: The discharge point is located approximately 8 miles south of the plant. Recycled water from both the East and West plants is conveyed through an outfall to this location. Recycled water flows directly into a lined portion of the San Gabriel River. A portion of the recycled water from this line is used for irrigation at the Sanitation Districts' Puente Hills Landfill and the Rose Hills Memorial Park; it is delivered to the Central Basin Municipal Water District's Recycled

Water System and can be diverted into the San Gabriel River Coastal Spreading Grounds for recharge.

- 001A: A turnout midway down the outfall pipe to 001 is used to divert recycled water to an unlined portion of the San Gabriel River, which allows percolation of recycled water to the groundwater.
- 002: The East WRP discharges recycled water from this point to an unlined portion of San Jose Creek that flows into the San Gabriel River. The recycled water, which is conveyed via various channels and diversion structures to either the Rio Hondo Spreading Grounds or the San Gabriel Coastal Spreading Grounds, is primarily used to recharge groundwater. During wet weather periods the water may continue downstream to the lined portion of the San Gabriel River.
- 003: The West WRP discharges recycled water from this point to an unlined portion of the San Gabriel River. The recycled water, which is conveyed via various channels and diversion structures to either the Rio Hondo Spreading Grounds or the San Gabriel Coastal Spreading Grounds, is primarily used to recharge groundwater. During wet weather periods the water may continue downstream to the lined portion of the San Gabriel River.

Whittier Narrows WRP

Nearly all of the recycled water from the WNWRP is reused. A portion of the water is directly used for irrigation or bus washing, with the remainder recharged to groundwater at the Rio Hondo Spreading Grounds or the San Gabriel Coastal Spreading Grounds.

The WNWRP has four discharge points. The discharge points are as follows:

- 001: The discharge point is located in the San Gabriel River above the Whittier Narrows Dam. Recycled water released at this discharge point is primarily used to recharge groundwater at the San Gabriel Coastal Spreading Grounds, but during wet weather periods the water may continue downstream to the lined portion of the San Gabriel River.
- 002: The discharge point is located in the Zone 1 Ditch. Recycled water released at this discharge point is primarily used to recharge groundwater at the Rio Hondo Spreading Grounds, but during wet weather periods the water may continue downstream to the Los Angeles River.
- 003: Formerly used to provide water to a groundwater test basin that was last used in 1981.
- 004: The discharge point is located in the Rio Hondo. Recycled water released at this discharge point is primarily used to recharge groundwater at the Rio Hondo Spreading Grounds, but during wet weather periods the water may continue downstream to the Los Angeles River.

Los Coyotes WRP

Some of the recycled water from the LCWRP is reused. Uses of recycled water include landscape irrigation in the cities of Cerritos and Bellflower, and supply to the Central Basin Municipal Water District's distribution system for irrigation, manufacturing, and cooling tower supply. Recycled water that is not used is discharged into the portion of the San Gabriel River that is concrete-lined from the point of discharge to the estuary (Discharge Point 001).

Long Beach WRP

The LBWRP supplies recycled water to the city of Long Beach. The city of Long Beach distributes the recycled water for various uses, including irrigation of parks, golf courses, athletic fields, and other landscaped areas, as well as oil-zone repressurization.

A portion of the LBWRP's effluent is further treated using microfiltration and reverse osmosis (MF/RO) and then disinfected using ultraviolet oxidation at the Water Replenishment District of Southern California (WRD) Leo J. Vander Lans Water Treatment Facility. The effluent from this facility is blended with imported water and pumped into the Alamitos Seawater Barrier to protect the Central Basin groundwater basin against seawater intrusion.

Recycled water from LBWRP that is not reused is discharged into a lined portion of Coyote Creek, about 2,200 feet upstream from its confluence with the San Gabriel River (Discharge Point 001). The San Gabriel River is lined at the Coyote Creek confluence.

La Cañada WRP

All effluent from the LCAWRP is reused for irrigation and surface impoundments at the La Cañada Flintridge Country Club.

3.3.2 JWPCP Requirements

The JWPCP has been providing full secondary treatment since November 2002. The secondary-treated effluent, after traveling approximately 6 miles through two tunnels, is discharged to the Pacific Ocean through two outfalls, Discharge Points 001 and 002 (120- and 90-inch outfalls, respectively). Two additional outfalls, Discharge Points 003 and 004 (72 inches and 60 inches, respectively), are permitted and available on standby to provide hydraulic relief, as necessary. Discharge Points 001 and 002 are located approximately one and a half miles off the coast. The diffuser sections are distributed between depths of 195 and 210 feet, and provide an initial minimum dilution of 166:1. Discharge Points 003 and 004 provide initial minimum dilutions of 150:1 and 115:1, respectively.

The final effluent must meet the limits listed in Table 3-5 through Table 3-9, which are prescribed by the plant's NPDES permit.

Table 3-5. NPDES Permit Limits for Major Wastewater Constituents for JWPCP Ocean Discharge

Constituent	Units	Effluent Limitations				
		Average Monthly	Average Weekly	Maximum Daily	Instantaneous Minimum	Instantaneous Maximum
BOD	mg/L	30	45	-	-	-
(5-day @ 20°C)	lbs/day	96,300	144,500	-	-	-
TSS	mg/L	30	45	-	-	-
	lbs/day	96,300	144,500	-	-	-
pH	standard units	-	-	-	6.0	9.0
Oil and Grease	mg/L	15	22.5	45	-	75
	lbs/day	48,200	72,200	144,500	-	-
Settleable Solids	mL/L	0.5	0.75	1.5	-	3.0
Turbidity	NTU	75	100	-	-	225
Temperature	°F	-	-	-	-	100
Removal of BOD and TSS	%	≥ 85	-	-	-	-

BOD = biochemical (or biological) oxygen demand

lbs/day = pounds per day

mg/L = milligrams per liter

mL/L = milliliters per liter

NTU = nephelometric turbidity unit

TSS = total suspended solids

pH = hydrogen ion concentration

Table 3-6. NPDES Permit Limits for Marine Aquatic Life Toxicants for JWPCP Ocean Discharge Points 001 and 002

Constituent	Units	Effluent Limitations		
		Average Monthly	Maximum Daily	Instantaneous Maximum
Chlorine Residual	µg/L	330	1,300	10,000
	lbs/day	1,060	4,170	-
Acute Toxicity	TUa	-	5.3	-
Chronic Toxicity	TUc	-	167	-

µg/L = micrograms per liter
 lbs/day = pounds per day
 TUa = acute toxicity unit
 TUc = chronic toxicity unit

Table 3-7. NPDES Permit Limits for Human Health Toxicants (Carcinogens) for JWPCP Ocean Discharge Points 001 and 002

Constituent	Average Monthly Effluent Limits	
	µg/L	lbs/day
Benzidine	0.012	0.039
Chlordane	0.0038	0.012
DDT	0.028	0.090
3,3'-Dichlorobenzidine	1.4	4.5
Hexachlorobenzene	0.035	0.11
PCBs	0.0032	0.010
TCDD Equivalents	0.65	2.1 x 10 ⁻⁶
Toxaphene	0.035	0.11

µg/L = micrograms per liter
 lbs/day = pounds per day
 DDT = dichloro-diphenyl-trichloroethane
 PCBs = polychlorinated biphenyls
 TCDD = 2,3,7,8-tetrachlorodibenzo-p-dioxin

Table 3-8. NPDES Permit Limits for Marine Aquatic Life Toxicants for JWPCP Ocean Discharge Points 003 and 004

Constituent	Units	Effluent Limitations, 003			Effluent Limitations, 004		
		AM	MD	IM	AM	MD	IM
Chlorine Residual	µg/L	300	1,200	9,100	230	930	7,000
Acute Toxicity	TUa		4.8			3.8	
Chronic Toxicity	TUc	-	151	-	-	116	-

AM = average monthly
 MD = maximum daily
 IM = instantaneous maximum
 µg/L = micrograms per liter
 TUa = acute toxicity unit
 TUc = chronic toxicity unit

Table 3-9. NPDES Permit Limits for Human Health Toxicants (Carcinogens) for JWPCP Ocean Discharge Points 003 and 004

Constituent	Units	Average Monthly Effluent Limits, 003	Average Monthly Effluent Limits, 004
Benzidine	µg/L	0.010	0.008
Chlordane	µg/L	0.0034	0.0027
DDT	µg/L	0.026	0.020
3,3'-Dichlorobenzidine	µg/L	1.2	0.93
Hexachlorobenzene	µg/L	0.032	0.024
PCBs	µg/L	0.0029	0.0022
TCDD Equivalents	pg/L	0.59	0.45
Toxaphene	µg/L	0.032	0.024

µg/L = micrograms per liter
pg/L = picograms per liter
DDT = dichloro-diphenyl-trichloroethane
PCBs = polychlorinated biphenyls
TCDD = 2,3,7,8-tetrachlorodibenzo-p-dioxin

Performance goals for Discharge Points 001 and 002 are also listed in Table 3-10. These performance goals are not enforceable effluent limitations or standards. However, the Sanitation Districts are required to maintain, if not improve, treatment efficiency to attain these goals. Any exceedance of the performance goals will trigger an investigation into the cause of the exceedance. If the exceedance is substantial or persists in successive monitoring periods, the Sanitation Districts are required to submit a written report to the LARWQCB on the nature of the exceedance, the results of the investigation as to the cause of the exceedance, and the corrective actions taken or proposed corrective measures with a timetable for implementation, if necessary. The JWPCP NPDES permit also includes narrative and numeric receiving water limitations for various constituents. These receiving water limits are summarized in Table 3-11 and Table 3-12.

Table 3-10. NPDES Permit Performance Goals for JWPCP Ocean Discharge Points 001 and 002

Constituent	Units	Average Monthly Performance Goal
Marine Aquatic Life Toxicants		
Arsenic	µg/L	2.5
Cadmium	µg/L	0.1
Chromium (VI)	µg/L	1.5
Copper	µg/L	4.9
Lead	µg/L	0.4
Mercury	µg/L	0.04
Nickel	µg/L	13
Selenium	µg/L	7.6
Silver	µg/L	0.2
Zinc	µg/L	37
Cyanide	µg/L	19
Chlorine Residual	µg/L	196
Ammonia as N	mg/L	40
Phenolic Compounds (Non-Chlorinated)	µg/L	3.6
Phenolic Compounds (Chlorinated)	µg/L	1.9
Endosulfan	µg/L	0.015
HCH	µg/L	0.015

Table 3-10 (Continued)

Constituent	Units	Average Monthly Performance Goal
Endrin	µg/L	0.01
Gross alpha radiation	pCi/L	6.3
Gross beta radiation	pCi/L	29
Human Health Toxicants – Non Carcinogens		
Acrolein	µg/L	5.2
Antimony	µg/L	9.8
Bis (2-Chloroethoxy) Methane	µg/L	1.3
Bis (2-Chloroisopropyl) Ether	µg/L	1.6
Chlorobenzene	µg/L	1.2
Chromium (III)	µg/L	3.3
Di-N-Butylphthalate	µg/L	4.4
Dichlorobenzene	µg/L	0.5
Diethyl Phthalate	µg/L	2.1
Dimethyl Phthalate	µg/L	1.9
2-Methyl-4,6-Dinitrophenol	µg/L	13
2,4-Dinitrophenol	µg/L	17
Ethylbenzene	µg/L	1.9
Flouranthene	µg/L	1.9
Hexachlorocyclopentadiene	µg/L	7.5
Nitrobenzene	µg/L	2.2
Thallium	µg/L	0.6
Toluene	µg/L	0.5
Tributyltin	µg/L	0.01
1,1,1-Trichloroethane	µg/L	1.8
Human Health Toxicants – Carcinogens		
Acrylonitrile	µg/L	2.7
Aldrin	µg/L	0.0037
Benzene	µg/L	0.75
Beryllium	µg/L	0.15
Bis (2-Chloroethyl) Ether	µg/L	0.95
Bis (2-Ethylhexyl) Phthalate	µg/L	17
Carbon Tetrachloride	µg/L	1
Chlorodibromomethane	µg/L	0.6
Chloroform	µg/L	30
1,4-Dichlorobenzene	µg/L	1
1,2-Dichloroethane	µg/L	0.6
1,1-Dichloroethylene	µg/L	1.1
Bromodichloromethane	µg/L	2
Dichloromethane	µg/L	3
1,3-Dichloropropene	µg/L	0.65
Dieldrin	µg/L	0.005
2,4-Dinitrotoluene	µg/L	1
1,2-Diphenylhydrazine	µg/L	0.65
Halomethanes	µg/L	1
Heptachlor	µg/L	0.005

Table 3-10 (Continued)

Constituent	Units	Average Monthly Performance Goal
Heptachlor epoxide	µg/L	0.0033
Hexachlorobutadiene	µg/L	0.7
Hexachloroethane	µg/L	0.7
Isophorone	µg/L	0.65
N-Nitrosodimethylamine	µg/L	0.7
N-Nitrosodi-N-Propylamine	µg/L	0.6
N-Nitrosodiphenylamine	µg/L	0.75
PAHs	µg/L	0.95
1,1,2,2-Tetrachloroethane	µg/L	0.4
Tetrachloroethylene	µg/L	20
Trichloroethylene	µg/L	0.85
1,1,2-Trichloroethane	µg/L	0.45
2,4,6-Trichlorophenol	µg/L	0.6
Vinyl Chloride	µg/L	1.3

µg/L = micrograms per liter
 N = nitrogen
 mg/L = milligrams per liter
 HCH = hexachlorocyclohexane
 pCi/L = picocuries per liter
 PAHs = polycyclic aromatic hydrocarbons

Table 3-11. JWPCP Receiving Water Bacteria Limits

Marine Water Designated for Water Contact Recreation (Rec-1)		
5-Sample (or 30-Day) Geometric Mean	Total coliform density	1,000/100 mL
	Fecal coliform density	200/100 mL
	Enterococcus density	35/100 mL
Single Sample Maximum	Total coliform density	10,000/100 mL
	Fecal coliform density	400/100 mL
	Enterococcus density	104/100 mL
	Total coliform density, when fecal coliform/total coliform ratio exceeds 0.1	1,000/100 mL
	Total coliform density must not exceed 1,000/100 mL for more than 20 percent of the samples at any sampling station in any 30-day period	
Marine Waters Where Shellfish May Be Harvested for Human Consumption		
Median for 6-month period	Total coliform	70/100 mL
Not more than 10% of samples for a 6-month period	Total coliform	230/100 mL

mL = milliliter

Table 3-12. Additional Prohibitions on Effects on Receiving Water by JWPCP Discharge

Physical Characteristics	<ul style="list-style-type: none"> ▪ Floating particulates ▪ Visible oil and grease ▪ Aesthetically undesirable discoloration of the ocean surface ▪ Significant reductions in the transmittal of natural light at any point outside the initial dilution zone ▪ Change in the rate of deposition of inert solids and the characteristics of inert solids in ocean sediments such that benthic communities are degraded
Chemical Characteristics	<ul style="list-style-type: none"> ▪ Dissolved oxygen concentration at any time depressed more than 10 percent from that which occurs naturally ▪ Change in pH of the receiving water at any time more than 0.2 units from that which occurs naturally ▪ Significant increase in dissolved sulfide concentrations of water and sediments above those present under natural conditions ▪ Increase in the concentration of substances set forth in Chapter II, Table B, of the Ocean Plan in marine sediments to levels that would degrade indigenous biota ▪ Increase of concentrations of organic materials in marine sediments to levels that would degrade marine life ▪ Objectionable aquatic growths or degradations of indigenous biota due to levels of nutrients in waste discharged
Biological Characteristics	<ul style="list-style-type: none"> ▪ Degradation of marine communities, including vertebrate, invertebrate, and plant species ▪ Alteration of the natural taste, odor, and color of fish, shellfish, or other marine resources used for human consumption ▪ Bioaccumulation of organic materials concentrations in fish, shellfish, or other marine resources used for human consumption to levels that are harmful to human health
Radioactivity	<ul style="list-style-type: none"> ▪ Degradation of marine life due to radioactive waste

3.4 Regulations for Drinking Water

3.4.1 Federal Regulations

3.4.1.1 Safe Drinking Water Act

The Safe Drinking Water Act (SDWA), passed in 1974, established a national program for protecting the quality of drinking water provided by public water suppliers. Under the SDWA, the EPA issued primary and secondary drinking water standards that are the minimum water quality standards that must be established by all states. Primary drinking water standards are water quality limits for contaminants that may cause or transmit disease, chemical poisoning, or other impairments to humans. Secondary drinking water standards are water quality limits for assuring aesthetically adequate drinking water in terms of appearance, taste, and odor. Under the SDWA, states with approved drinking water protection programs, such as California, have implementation and enforcement authority.

The 1986 amendments to the SDWA required the EPA to promulgate new standards for certain contaminants and establish requirements for the protection of groundwater supplies. The 1996 amendments to the SDWA provided new approaches to prevent contamination of drinking water, better information for consumers, regulatory improvements, and new funding for states and communities through a Safe Drinking Water State Revolving Fund (SDWSRF).

3.4.2 State Regulations

3.4.2.1 California Drinking Water Standards

California drinking water standards (CDWS) are promulgated by the California Department of Public Health (CDPH) under the California Safe Drinking Water Act. Typically, the CDWS are the same as the federal standards. Recycled water that is used to recharge groundwater or that is discharged to a surface water body designated as a drinking water supply must generally meet CDWS for trace constituents.

3.5 Regulations for Water Reuse

The discharge and reuse of recycled water is regulated at the state and local level.

3.5.1 State Regulations

State requirements for production, discharge, distribution, and use of recycled water are contained in the following codes:

- CWC, Division 7 – Water Quality, Sections 13000 through 13999.19
- CCR, Title 22 Social Security, Division 4 – Environmental Health, Chapter 3, Recycling Criteria, Sections 60301 through 60475
- CCR, Title 17 Public Health, Division 1 – State Department of Health, Chapter 5, Sanitation (Environmental), Subchapter 1, Engineering (Sanitary), Group 4, Drinking Water Supplies, Sections 7583 through 7630

In addition, guidelines for production, distribution, and use of recycled water have been prepared or endorsed by state agencies administering recycled water regulations.

3.5.1.1 California Water Code

The CWC contains requirements for the production, discharge, and use of recycled water. Division 7, Chapter 7, of the CWC specifically addresses requirements for water recycling. This chapter requires CDPH to establish water recycling criteria and gives the RWQCBs responsibility for prescribing specific WRRs for water that is used or proposed to be used as recycled water. In addition, Division 7, Chapter 7, of the CWC regulates recycled water injected into the ground and requires that greenbelt areas and certain other applications must use recycled water rather than potable water where recycled water is available at a cost-effective price.

Sections 1210 and 1212 of the CWC, added in 1980, focus on the definition of property rights to recycled water. These sections require that the owner of a wastewater treatment plant obtain approval from the SWRCB prior to making any change to the point of discharge, place of use, and/or purpose of use of recycled water.

3.5.1.2 Title 22

In 1975, the CDPH prepared Title 22 of the CCR to fulfill the requirements of the CWC. Title 22 was subsequently revised in 1978 to conform with the 1977 amendments to the CWA and was revised again in December 2000. The requirements of Title 22 regulate production and use of recycled water in

California. Criteria for reuse of secondary and tertiary effluent in various reuse applications include limits on the maximum numbers of total coliform bacteria present within the water.

Title 22 establishes four categories of recycled water:

- Undisinfected Secondary Recycled Water: oxidized effluent
- Disinfected Secondary-23 Recycled Water: oxidized and disinfected effluent that does not exceed an MPN of 23 total coliform bacteria per 100 mL median concentration in a 7-day period
- Disinfected Secondary-2.2 Recycled Water: oxidized and disinfected effluent that does not exceed an MPN of 2.2 total coliform bacteria per 100 mL median concentration in a 7-day period
- Disinfected Tertiary Recycled Water: oxidized, coagulated, clarified, filtered, and disinfected effluent

Suitable uses of recycled water, as defined by the December 2000 revision of Title 22, are summarized in Table 3-13.

Table 3-13. Suitable Uses of Recycled Water

Use	Undisinfected Secondary Recycled Water	Disinfected Secondary- 23 Recycled Water	Disinfected Secondary- 2.2 Recycled Water	Disinfected Tertiary Recycled Water
Surface Irrigation				
Food crops where recycled water contacts the edible portion of the crop	Not Allowed	Not Allowed	Not Allowed	Allowed
Parks and playgrounds	Not Allowed	Not Allowed	Not Allowed	Allowed
School yards	Not Allowed	Not Allowed	Not Allowed	Allowed
Residential landscaping	Not Allowed	Not Allowed	Not Allowed	Allowed
Unrestricted access golf courses	Not Allowed	Not Allowed	Not Allowed	Allowed
Other irrigation uses not prohibited by other provisions of the CCR	Not Allowed	Not Allowed	Not Allowed	Allowed
Food crops where the edible portion is produced above ground and not contacted by recycled water, other than orchards and vineyards	Not Allowed	Not Allowed	Allowed	Allowed
Cemeteries	Not Allowed	Allowed	Allowed	Allowed
Freeway landscaping	Not Allowed	Allowed	Allowed	Allowed
Restricted access golf courses	Not Allowed	Allowed	Allowed	Allowed
Nonedible vegetation at other areas where access control prevents use as if land were a park	Not Allowed	Allowed	Allowed	Allowed
Ornamental nursery stock and sod farms where access by the general public is not restricted	Not Allowed	Allowed	Allowed	Allowed
Pasture for animals producing milk for human consumption	Not Allowed	Allowed	Allowed	Allowed
Orchards and vineyards where recycled water does not contact the edible portion of the crop (e.g., pistachios and chestnuts)	Allowed	Allowed	Allowed	Allowed
Non food-bearing trees	Allowed	Allowed	Allowed	Allowed
Pastures for animals not producing milk for human consumption	Allowed	Allowed	Allowed	Allowed
Seed crops not eaten by humans	Allowed	Allowed	Allowed	Allowed
Food crops that must undergo commercial pathogen-destroying processing before consumption (e.g., sugar beets)	Allowed	Allowed	Allowed	Allowed

Table 3-13 (Continued)

Use	Undisinfected Secondary Recycled Water	Disinfected Secondary- 23 Recycled Water	Disinfected Secondary- 2.2 Recycled Water	Disinfected Tertiary Recycled Water
Ornamental nursery stock and sod farms with no irrigation 14 days before harvest, retail sale, or public access	Allowed	Allowed	Allowed	Allowed
Fodder crops (e.g., alfalfa) and fiber crops (e.g., cotton)	Allowed	Allowed	Allowed	Allowed
Supply for Impoundments				
Non-restricted recreational impoundment	Not Allowed	Not Allowed	Not Allowed	Allowed ^a
Restricted recreational impoundment	Not Allowed	Not Allowed	Allowed	Allowed
Fish hatchery with public access	Not Allowed	Not Allowed	Allowed	Allowed
Landscape impoundment without decorative fountain	Not Allowed	Allowed	Allowed	Allowed
Supply for Cooling or Air Conditioning				
System with cooling tower, evaporative condenser, spray, or mechanism that can create mist, with high efficiency draft reducer and effective biocide level in circulated water	Not Allowed	Not Allowed	Not Allowed	Allowed
System without cooling tower, evaporative condenser spray, or mechanism that can create mist	Not Allowed	Allowed	Allowed	Allowed
Other Uses				
Flushing toilets and urinals	Not Allowed	Not Allowed	Not Allowed	Allowed
Priming drain traps	Not Allowed	Not Allowed	Not Allowed	Allowed
Industrial process water that may contact workers	Not Allowed	Not Allowed	Not Allowed	Allowed
Structural fire fighting	Not Allowed	Not Allowed	Not Allowed	Allowed
Decorative fountains	Not Allowed	Not Allowed	Not Allowed	Allowed
Commercial laundries	Not Allowed	Not Allowed	Not Allowed	Allowed
Consolidation of backfill material around potable water pipelines	Not Allowed	Not Allowed	Not Allowed	Allowed
Artificial snow making for commercial outdoor use	Not Allowed	Not Allowed	Not Allowed	Allowed
Commercial car washes, including hand washes if water is not heated, where public is excluded from washing process	Not Allowed	Not Allowed	Not Allowed	Allowed
Industrial boiler feed	Not Allowed	Allowed	Allowed	Allowed
Nonstructural fire fighting	Not Allowed	Allowed	Allowed	Allowed
Backfill consolidation around nonpotable water piping	Not Allowed	Allowed	Allowed	Allowed
Soil compaction	Not Allowed	Allowed	Allowed	Allowed
Mixing concrete	Not Allowed	Allowed	Allowed	Allowed
Dust control on roads and streets	Not Allowed	Allowed	Allowed	Allowed
Cleaning roads, sidewalks, and outdoor work areas	Not Allowed	Allowed	Allowed	Allowed
Industrial process water that will not contact workers	Not Allowed	Allowed	Allowed	Allowed
Flushing sanitary sewers	Allowed	Allowed	Allowed	Allowed

^a With monitoring for enteric viruses and protozoan cysts.

In addition to defining permitted uses of recycled water and treatment requirements, Title 22 defines requirements for sampling and analysis of effluent at treatment plants, requires preparation of an engineering report prior to production or use of recycled water, specifies general design criteria for treatment facilities, establishes reliability requirements, and addresses alternative methods of treatment.

3.5.1.3 Water Reclamation Requirements

Use of recycled water is usually regulated by the RWQCB under WRRs. The LARWQCB has adopted WRRs for the JOS WRPs, including the POWRP, SJCWRP, WNWRP, LCWRP, LBWRP, and LACAWRP. The JOS WRR Order Numbers are summarized in Table 3-2. The WRR permit limits for specific constituents are summarized in Table 3-4.

When these WRR permits are renewed, they will likely become incorporated into master reclamation permits. A master reclamation permit is authorized under the CWC to replace WRRs and establishes six different types of procedural and substantive requirements intended to assure protection of the environment, including compliance with uniform statewide reclamation criteria. The issuance of a master reclamation permit is an approach taken in the past for oversight of municipal, nonpotable reuse projects that do not represent a significant impact to groundwater quality. This approach would allow recycled water users to operate under a master reclamation permit for each of the JOS WRPs, facilitating the permitting process for appropriate municipal reuse projects. Uses for disinfected tertiary recycled water that are widely accepted and implemented as appropriate with minimal or no impacts to receiving waters are listed in Table 3-13.

3.5.1.4 SWRCB Recycled Water Policy

On February 3, 2009, the SWRCB released a recycled water policy (Resolution No. 2009-0011). The purpose of this policy is to increase the use of recycled water in a manner that implements state and federal water quality laws and provide direction to RWQCBs, proponents of recycled water projects, and the public regarding appropriate criteria to be used by the SWRCB and RWQCBs in issuing permits for recycled water projects. The policy includes language that:

- Establishes goals to increase the use of recycled water in California and clarifies the roles of the SWRCB, RWQCBs, CDPH, and the California Department of Water Resources (DWR)
- Requires development of salt and nutrient management plans for each groundwater basin by 2014
- Establishes a “blue-ribbon” advisory panel to guide future actions relating to Emerging Constituents/Constituents of Emerging Concern (CEC)

3.5.1.5 SWRCB Recycled Water General Irrigation Permit

The California Legislature declared its intent to promote the use of recycled water as a valuable resource and a significant component of California’s water supply. In response, the SWRCB issued the General Waste Discharge Requirements for Landscape Irrigation Uses of Municipal Recycled Water (General Permit) to streamline the regulatory process for reuse of disinfected tertiary recycled water for:

- Parks, greenbelts, and playgrounds
- School yards
- Athletic fields
- Golf courses
- Cemeteries
- Residential landscaping and common areas
- Commercial landscaping, except eating areas
- Industrial landscaping, except eating areas

- Freeway, highway, and street landscaping

The SWRCB adopted the General Permit on July 7, 2009.

3.5.1.6 CDPH Draft Groundwater Recharge Regulations

The CDPH issued new Draft Groundwater Recharge Reuse Regulations on August 5, 2008. The CDPH is currently revising these draft regulations and it is anticipated that elements of the 2008 draft may change in the new version. Key elements of the 2008 draft groundwater recharge regulations for groundwater reuse recharge projects (GRRPs) include:

- All recycled water recharged in a GRRP is to be retained underground for a minimum of 6 months prior to extraction for use as a drinking water.
- Control of nitrogen compounds and regulated chemicals and physical characteristics is required.
- For each spreading area or subsurface injection facility recharged by the GRRP, total organic carbon (TOC) must be monitored. The TOC analytical results for filtered wastewater samples are not to exceed 16 mg/L (for two consecutive samples and the average of the last four results). The TOC analytical results for recharge water are not to exceed 0.5 mg/L divided by the recycled water contribution (RWC) (based on a 20-week running average). Exceptions are made to this limit under certain conditions as outlined in Section 60320.045 of the regulation.
- The initial RWC shall not exceed 0.50 for direct injection projects, 0.50 for surface spreading projects with advanced treatment, and 0.20 for surface spreading projects without advanced treatment.

The CDPH groundwater reuse recharge draft regulations include requirements to increase the project RWC. The ability to increase the RWC indicates potential opportunities for increased groundwater recharge capacity within the JOS. The proposed requirements include the following:

- Reports to CDPH including operations, monitoring, and compliance data demonstrating that the maximum RWC and maximum contaminant levels (MCLs) are not exceeded. Engineering and scientific reports will be subject to peer review by an advisory panel including scientific experts within disciplines specified by CDPH.
- Reverse osmosis treatment of recycled water as well as subsequent advanced oxidation treatment such that, at a minimum, a 1.2 log N-nitrosodimethylamine (NDMA) reduction and a 0.5 log 1,4-dioxane reduction are achieved.
- Recycled water analysis and annual reports prepared for any new compounds identified by CDPH, in addition to any other required monitoring.

3.5.1.7 Title 17

The focus of Title 17 of the CCR is the protection of potable water supplies through control of cross connections with potential contaminants. Examples of potential contaminants include sewage; nonpotable water supplies such as recycled water, irrigation water, and auxiliary water supplies; fire protection systems; and hazardous substances.

Title 17, Group 4, Article 2 (Protection of Water System), Table 1, specifies the minimum backflow protection required on a potable water system when there is a potential for contamination of the potable water supply. Recycled water is addressed in two instances as follows:

- An air-gap separation is required on premises where the public water system is used to supplement the recycled water supply.
- An air-gap separation is required on premises where recycled water is used and there is no interconnection with the potable water system; however, a reduced pressure principle backflow prevention device may be provided in lieu of an air gap, if approved by the health agency and water supplier.

3.5.1.8 Recycled Water Guidelines

To assist in compliance with Title 22, CDPH has prepared a number of guidelines for the production, distribution, and use of recycled water. Additionally, CDPH recommends the use of guidelines for distribution of recycled water that have been prepared by the California-Nevada Section of the American Water Works Association (AWWA). These guidelines include:

- Guidelines for the Preparation of an Engineering Report on the Production, Distribution, and Use of Recycled Water
- Manual of Cross-Connection Control/Procedures and Practices
- Guidelines for the Distribution of Nonpotable Water
- Guidelines for the Use of Recycled Water
- Guidelines for the Use of Recycled Water for Construction Purposes

3.5.1.9 Recycled Water Administration

In the state of California, recycling requirements are administered by the SWRCB, RWQCB, and CDPH. The direct involvement of each agency during a water recycling project is as follows:

- The SWRCB issues loans in accordance with the CWC and approves petitions for a change in place and/or purpose of use of recycled water in accordance with the CWC.
- The RWQCB prepares or revises WRRs in accordance with the CWC and Title 22, reviews and approves engineering reports required under Title 22, and reviews and approves recharge projects using recycled water in accordance with the CWC.
- The CDPH provides recommendations to the RWQCB on WRRs and reviews and approves engineering reports, final plans for cross-connection control and pipeline separations in accordance with Title 17, and final user system plans in conjunction with local health agencies for cross-connection control in accordance with Title 17. The CDPH also inspects distribution systems prior to operation.

3.5.1.10 Public Utilities Code

The 2010 California Public Utilities Code contains requirements for distribution and use of recycled water. Per Chapter 8.5 of the code, Service Duplication, a political subdivision is prohibited from extending similar or duplicating facilities into the service areas of a privately owned public utility.

3.5.1.11 Nonpotable Water Reuse Systems

Chapter 16A, Nonpotable Water Reuse systems, was added to the 2007 California Plumbing Code on August 4, 2009. These regulations were developed to encourage the use of graywater. Chapter 16A is intended to provide guidance to code users and the flexibility to make legal compliance easily achievable.

The use of graywater conserves water by facilitating greater reuse of laundry, shower, lavatory, and similar sources of discharge for irrigation. Graywater reuse also diverts discharge of these sources from the sewerage system.

3.5.2 Local Regulations

Local requirements focus on the distribution and use of recycled water and, primarily, on the user systems. Local requirements generally emphasize cross-connection control. The state regulations and guidelines discussed in Section 3.5.1 are the governing requirements. The Los Angeles County Department of Public Health (County DPH) generally establishes more specific requirements for separation and construction of potable and recycled water systems, specifies guidelines for user systems, and establishes criteria for identification of recycled water facilities.

3.5.2.1 Local Regulations Administration

Local requirements are administered by the County DPH or the applicable local health department. The direct involvement of the County DPH in a recycled water project generally includes, but is not necessarily limited to, review of as-built drawings of users' potable water systems, performance of onsite surveys of users' water systems, provision of guidance to users with respect to methods of identifying potable and recycled water systems, review and approval of design drawings of users' recycled water systems, and inspection of users' potable and recycled water systems and cross-connection controls following construction.

3.6 Regulations for Wet Weather Flow Management

While the 1972 Clean Water Act placed a great deal of emphasis on establishing treatment permit limits to protect receiving water quality, the importance of avoiding conveyance system overflows and plant bypasses during high flow events is also recognized. This section provides an overview of the federal and state requirements pertinent to the management of wet weather flows in the conveyance system.

3.6.1 Federal Regulations

The EPA proposed a draft Sanitary Sewer Overflow (SSO) Rule in 2001 that would require municipalities to establish the capacity of the wastewater conveyance system under a strict sanitary sewer overflow prohibition. The SSO Rule is also commonly referred to as CMOM, which stands for capacity, management, operations, and maintenance. Three provisions of the proposed SSO Rule emphasize the capacity relevance of managing SSOs and their impact on public health and the environment. These include:

- Provide adequate capacity to convey base and peak flows
- Take all feasible steps to stop and mitigate impacts of SSOs
- Undertake a system evaluation and capacity assurance program

These provisions are found in both the general standards and the CMOM program components. The state's WDRs have embraced the intent and purpose of EPA's proposed SSO rule and are expected to meet all related requirements if the rule is passed.

3.6.2 State Regulations

The primary regulations governing wet weather planning and design for sanitary sewer systems in California have been promulgated at the state level. On May 2, 2006, the SWRCB issued statewide WDRs for sanitary sewer systems with more than 1 mile of pipes or sewer lines that are also owned by public agencies. The SWRCB is currently exploring revisions to the WDRs, and released revised draft WDRs in March 2011.

3.6.2.1 Enforcement Discretion

Within the statewide WDRs, Provision 6 of Section D indicates that RWQCBs must consider whether “the sanitary sewer system design capacity is appropriate to reasonably prevent SSOs” in any enforcement action. This intent to prevent SSOs is based on the current interpretation of the CWA by the EPA that all SSOs to waters of the U.S. are illegal and, therefore, prohibited. The word “reasonably” was included in the language, however, as recognition that it is impossible to design a sewer system large enough to prevent every single capacity-related SSO.

3.6.2.2 Use of Professional Judgment

Because design storms are not specified by regulations applicable in California, agencies must use professional judgment to design the size of sewer systems to prevent SSOs. The term “reasonably” is not defined in a regulatory context. Several approaches are currently being used, which often include identification of alternative design storm sizes for various parts of the sewer system (depending on the potential impacts of SSOs on local receiving waters) and a comparison of the costs and benefits of these alternatives to arrive at a reasonable approach.

3.6.2.3 Sewer System Management Plan

The statewide WDRs also require the development of a sewer system management plan (SSMP) in which the approach to sewer system capacity is documented. A WDR implementation schedule was issued by the SWRCB on July 7, 2005, which requires completion of SSMP elements by August 31, 2008, with intermediate dates on some of the elements. The most recent version of the Sanitation Districts’ SSMP was completed in May 2009.

3.7 Regulations for Air Quality

The federal Clean Air Act (CAA) and its subsequent amendments established air quality regulations and the National Ambient Air Quality Standards (NAAQS), and delegated enforcement of these standards to the states. In California, the California Air Resources Board (CARB) is responsible for enforcing air pollution regulations. CARB, in turn, has delegated the responsibility of regulating stationary emission sources to the local air agencies. In the South Coast Air Basin (SCAB), the local regulatory air agency is the South Coast Air Quality Air District (SCAQMD).

The following is a summary of the key federal, state, regional, and local air quality rules, policies, and agreements that apply to the JOS.

3.7.1 Federal Regulations

3.7.1.1 State Implementation Plans

The federal CAA requires each state to prepare a State Implementation Plan (SIP) that details how the federally designated nonattainment areas will achieve the NAAQS. In California, each air district prepares an air quality management plan (AQMP) to incorporate into the state's SIP. SCAQMD prepared the 2007 AQMP for inclusion into the California SIP.

The 2007 AQMP addresses several federal planning requirements and incorporates significant new scientific data, primarily in the form of updated emissions inventories, updated ambient measurements, new meteorological episodes, and new air quality modeling tools. The 2007 AQMP builds upon the approaches taken in the 2003 AQMP for the SCAB for the attainment of federal air quality standards. The AQMP highlights the necessary reductions and the need to identify additional strategies, especially in the area of mobile sources, to meet federal criteria pollutant standards within the timeframes allowed under the federal CAA (SCAQMD 2007).

3.7.1.2 Greenhouse Gases

Federal regulations requiring reporting or reduction of greenhouse gas (GHG) emissions are in various stages of development or implementation. In the 2007 U.S. Supreme Court case *Massachusetts v. EPA*, the court ruled that carbon dioxide (CO₂) and other GHGs are air pollutants that could be regulated by the EPA. Subsequent to the court case, the EPA Administrator signed a document making two significant findings with regard to GHG emissions, thereby allowing the EPA to proceed with rulemaking. The ultimate implementation of the federal GHG regulations may be preempted by congressional action.

The President's Council on Environmental Quality (CEQ) issued draft guidance on how GHG emissions should be handled under the National Environmental Policy Act (NEPA). Based on this guidance, federal agencies, such as the Corps, will not make an impact determination under NEPA for GHG emissions but, instead, use a reference point above which they are required to consider any additional environmental review.

3.7.1.3 Environmental Protection Agency Off-Road Diesel Engine Rule

To reduce emissions from off-road diesel equipment, the EPA established a series of increasingly strict emission standards for new engines. Locomotives and marine vessels are exempt from this rule. Manufacturers of off-road diesel engines would be required to produce engines with certain emission standards under the following compliance schedule:

- Tier 1 standards were phased in from 1996 to 2000 (year of manufacture), depending on the engine horsepower category
- Tier 2 standards were phased in from 2001 to 2006
- Tier 3 standards were phased in from 2006 to 2008
- Tier 4 standards, which likely will require add-on emissions control equipment to attain them, will be phased in from 2008 to 2015

3.7.1.4 Environmental Protection Agency On-Road Diesel Engine Rule

In 2007, the EPA promulgated the Heavy-Duty Highway Rule, which reduces emissions from on-road, heavy-duty diesel trucks by establishing a series of increasingly strict emission standards for new engines. Manufacturers are required to produce new diesel vehicles that meet particulate matter (PM) and mono-nitrogen oxide (NO_x) emission standards beginning with model year 2007.

3.7.1.5 Environmental Protection Agency Marine Diesel Engine Rule

For the purpose of emission regulations, marine engines are divided into three categories based on displacement per cylinder, as listed in Table 3-14. Each of the categories represents a different engine technology. Categories 1 and 2 are further divided into subcategories, depending on displacement and net power output.

Table 3-14. Environmental Protection Agency Marine Engine Categories

Category	Displacement per Cylinder (D)	Basic Engine Technology	Type of Vessels	Range in Engine Size
1	Subcategory 1–2: D < 5 dm ³ and power > 37 kW	Land-based non-road diesel	Tugboats, pushboats, fishing vessels, commercial vessels in and around ports, and supply vessels	500 to 8,000 kW (700 to 11,000 hp)
	Subcategory 3–4: D < 7 dm ³			
2	Subcategory 1–2: 5 dm ³ < D < 30 dm ³	Locomotive diesel	Same as above	500 to 8,000 kW (700 to 11,000 hp)
	Subcategory 3–4: 7 dm ³ < D < 30 dm ³			
3	D > 30 dm ³	Unique marine engine design	Container ships, oil tankers, bulk carriers, and cruise ships	2,500 to 70,000 kW (3,000 to 100,000 hp)

dm³ = cubic decimeters
kW = kilowatts
hp = horsepower

On March 14, 2008, the EPA signed a regulation to introduce Tier 3 and Tier 4 emission standards to new or rebuilt Category 1 and Category 2 marine diesel engines. Tier 3 standards apply to new engines used in commercial, recreation, and auxiliary power applications beginning in 2009 for Category 1 engines and in 2013 for Category 2 engines. Tier 4 standards apply to new Category 1 and 2 engines above 600 kW on commercial vessels beginning in 2014. For remanufactured engines, standards apply only to commercial marine diesel engines above 600kW when the engines are remanufactured and as soon as certified systems are available.

3.7.1.6 Environmental Protection Agency Diesel Fuel Rule

This EPA rule limited the sulfur content in on-road diesel fuel to 15 ppm starting June 1, 2006 (EPA 2006).

3.7.1.7 Conformity Rule

Section 176(c) of the CAA states that a federal agency cannot issue a permit for or support an activity unless the agency determines it would conform to the most recent EPA-approved SIP. This means that

projects using federal funds or requiring federal approval must not (1) cause or contribute to any new violation of a NAAQS, (2) increase the frequency or severity of any existing violation, or (3) delay the timely attainment of any standard, interim emission reduction, or other milestone (EPA 2010a).

Based on the present NAAQS attainment status of the SCAB, a federal action would conform to the SIP if its annual emissions remain below 100 tons of carbon monoxide (CO) and fine particulate matter less than 2.5 microns in diameter (PM_{2.5}), 70 tons of respirable particulate matter less than 10 microns in diameter (PM₁₀), and 10 tons of NO_x or volatile organic compounds (VOCs) (EPA 2010b). These de minimis thresholds apply to the proposed construction and operation activities pertaining to the federal action. If the proposed action exceeds one or more of the de minimis thresholds, a more rigorous conformity determination is the next step in the conformity evaluation process. SCAQMD Rule 1901 adopts the guidelines of the General Conformity Rule.

3.7.2 State Regulations

3.7.2.1 California Clean Air Act

The California Clean Air Act of 1988, as amended in 1992, outlines a program to attain the California Ambient Air Quality Standards (CAAQS) by the earliest practical date. Because the CAAQS are more stringent than the NAAQS, attainment of the CAAQS will require more emissions reductions than what would be required to show attainment of the NAAQS. Consequently, the main focus of attainment planning in California has shifted from the federal to state requirements. Similar to the federal system, the state requirements and compliance dates are based on the severity of the ambient air quality standard violation within a region.

The JOS facilities are located within the jurisdiction of the SCAQMD, which is classified as a severe nonattainment area for ozone and a nonattainment area for PM₁₀ and PM_{2.5}.

3.7.2.2 Heavy-Duty Diesel Truck Idling Regulation

CARB's heavy-duty diesel truck idling regulation affected heavy-duty diesel trucks in California beginning in 2008. The rule requires that heavy-duty trucks be equipped with a non-programmable engine system that shuts down the engine after 5 minutes to prevent long idling times or, as an alternative, meet a stringent NO_x idling emission standard.

3.7.2.3 California Diesel Fuel Regulation

CARB's diesel fuel regulation set sulfur limits of 15 ppm for diesel fuel sold in California for use in on-road and off-road motor vehicles. Harbor craft were originally excluded from the rule but were later included by a 2004 rule amendment.

3.7.2.4 Portable Equipment Registration Program

The Portable Equipment Registration Program (PERP) established a uniform, statewide program to regulate portable engines and portable engine-driven equipment units (CARB 2010). Once registered in this program, engines and equipment units may operate throughout California without the need to obtain individual permits from local air districts. The portable equipment, however, cannot reside at the same location for more than 12 months. Some construction-related equipment may be registered under PERP.

3.7.2.5 On-Road Heavy-Duty Diesel Vehicles (In Use) Regulation

On December 12, 2008, CARB approved the on-road heavy-duty diesel vehicle (in use) regulation to significantly reduce PM and NO_x emissions from existing diesel vehicles operating in California. The regulation applies to nearly all diesel-fueled trucks and buses with a gross vehicle weight rating (GVWR) greater than 14,000 pounds that are privately or federally owned and for privately and publicly owned school buses.

Starting January 1, 2012, the regulation would phase in requirements for heavier trucks to reduce PM emissions with exhaust retrofit filters that capture pollutants before they are emitted to the air or by replacing vehicles with newer vehicles that are originally equipped with PM filters. Starting on January 1, 2015, lighter trucks with a GVWR of 14,001 to 26,000 pounds with engines that are 20 years or older would need to be replaced with newer trucks. Starting January 1, 2020, all remaining trucks and buses would need to be replaced so that they would all have 2010 model year engines or equivalent emissions by 2023.

Heavier trucks and buses with a GVWR greater than 26,000 pounds would have two ways to comply. Fleets could comply with a compliance schedule by engine model year or use a phase-in option where engine replacement could be delayed by installing a PM filter on the existing engine.

3.7.2.6 Off-Road Diesel Fleet Regulation

On July 26, 2007, CARB adopted a regulation to reduce diesel PM and NO_x emissions from existing off-road heavy-duty vehicles in California. This regulation applies to off-road vehicles with a 25 horsepower engine or greater, such as loaders, crawler tractors, skid steers, backhoes, forklifts, and two-engine cranes. The regulation does not apply to stationary equipment or portable equipment, such as generators. The off-road performance requirements are applied to a fleet as a whole and not to individual vehicles, and are based on a fleet's average NO_x emissions. The goal of the regulation is to encourage fleet owners to replace a certain percentage of their diesel fleet over time with cleaner emitting vehicles in order to meet the lower annual NO_x limits. This CARB rule is applicable to the off-road diesel vehicles that would be used during the construction of the program and project elements.

The regulation was amended in December 2010 to provide a 4-year delay from the original compliance timeline for all fleets. By January of each year, starting in 2014, each fleet must meet the fleet average NO_x requirements or, as an alternative, a specified percentage of the fleet must be replaced with newer engines. The percent turnover is referred to by CARB as best available control technology (BACT).

3.7.2.7 Airborne Toxic Control Measure for Commercial Harbor Craft

In 2007, the CARB approved a regulation to reduce emissions from diesel engines on commercial harbor craft vessels. The regulation was intended to reduce diesel particulate matter (DPM) and NO_x emissions from harbor craft engines. The rule became effective in 2009 and was amended in 2010. The rule includes new engine and in-use engine requirements for many diesel engines on commercial harbor craft. The compliance schedule is phased in such that it brings the oldest and highest use engines into compliance first. This CARB rule is applicable to marine engines on tugboats that would be used during the construction of the project elements.

3.7.2.8 Airborne Toxic Control Measure for Diesel Particulate Matter From Portable Engines

Effective February 19, 2011, diesel-fueled portable engines with a rated brake horsepower of 50 or greater are subject to the CARB's Airborne Toxic Control Measure (ATCM). The ATCM imposes fuel and DPM emission requirements for in-use and new portable diesel engines. Diesel fleets are required to meet certain DPM standards by set compliance dates. By January 1, 2020, new emergency standby diesel engines will need to be certified to Tier 4 emission standards.

3.7.2.9 Greenhouse Gases

The U.S. Supreme Court's ruling in the 2007 case *Massachusetts v. EPA* held that the EPA has authority to regulate GHG emissions from new vehicles under the CAA. In 2007, the California State Attorney General decided that the federal ruling gave California the right to regulate GHGs. Consequently, GHG emissions can be regulated in the state of California and the associated emission reduction plans can be enforced through existing air quality laws.

Office of Planning and Research CEQA Guidelines on Greenhouse Gases

The California Governor's Office of Planning and Research (OPR) developed amendments to the State CEQA Guidelines for addressing GHG emissions. These amendments became effective on March 18, 2010, when the Office of Administrative Law approved them. OPR did not define or set a CEQA threshold at which GHG emissions would be considered significant. Instead the lead agency would assess the significance of impacts from GHG emissions on the environment by considering a threshold that applies to the project and evaluate feasible mitigation measures.

In the SCAB, the SCAQMD has set a significance threshold for purposes of CEQA. The SCAQMD threshold will be used for evaluating potential GHG impacts of the Clearwater Program.

May 2008 Attorney General Greenhouse Gas CEQA Guidance Memo

In 2008, the California State Attorney General's office released a CEQA guidance memo related to GHG analysis and mitigation measures. The memo provides examples of mitigation measures that could be used in a diverse range of projects.

AB 32 – California Global Warming Solutions Act of 2006

AB 32 sets a statewide goal to reduce GHG emissions to 1990 levels by 2020. This act instructs CARB to adopt regulations that reduce emissions from significant sources of GHGs, and to establish a mandatory GHG reporting and verification program by January 1, 2008.

Wastewater processes are not considered a significant GHG emissions source. Additionally wastewater-related CO₂ emissions are biogenic in nature, not man-made. Consequently, wastewater treatment operations with anthropogenic emissions below 25,000 metric tons per year (mty) of carbon dioxide equivalent are categorically excluded in the state's emerging GHG cap and trade regulation, and are not included in the AB 32 Scoping Plan's Early Reduction Measures. Additionally, biogenic CO₂ emissions from wastewater treatment operations are not reported as direct, anthropogenic emissions under the state's Mandatory Reporting Rule.

AB 1493 – Vehicular Emissions of Greenhouse Gases

AB 1493 (Pavley), enacted on July 22, 2002, required CARB to develop and adopt regulations that reduce GHGs emitted by passenger vehicles and light duty trucks. Regulations adopted by CARB apply to 2009

and later model year vehicles. CARB estimates that the regulation will reduce climate change emissions from light duty passenger vehicle fleet by 18 percent in 2020 and 27 percent in 2030 (CARB 2004).

Low Carbon Fuel Standard

In January 2007, by Executive Order, the Governor established a low carbon fuel standard (LCFS) for transportation fuels sold in the state of California, where the initial goal is to reduce the carbon intensity of California's passenger vehicle fuels by at least 10 percent by 2020. Landfill gas, which is similar in nature to digester gas, qualifies as a low carbon fuel because of its very small carbon footprint.

3.7.3 Local Regulations

3.7.3.1 South Coast Air Quality Management District Rules and Regulations

Through the attainment planning process, SCAQMD has developed and adopted rules and regulations to address stationary sources of air pollution in the SCAB. The SCAQMD rules for stationary sources that are most pertinent to the Clearwater Program are listed in Table 3-15.

Table 3-15. SCAQMD Rules for Stationary Sources

SCAQMD Rule	Purpose of Rule
402	Nuisance rule that prohibits the discharge of air contaminants that causes injury and annoyance, endangers public health and safety, or damages property
403	Fugitive dust rule that prohibits dust from any active operation, open storage pile, or disturbed surface area that remains visible beyond the emission source property line. Requires best available control measures to be applied to earth moving and grading activities
1113	Sets a limit on the VOC content in architectural paint
1146	Sets NO _x limits for exhaust from large external combustion equipment, such as commercial boilers, steam generators, and process heaters
1166	Requires a mitigation plan for soil contaminated with VOCs
1402	Sets action triggers based on facility-wide risks for public notification and mandatory risk reduction
1470	Sets fuel requirements and limits operating hours on diesel engines
1472	Reduces diesel particulate emissions from facilities with three or more stationary emergency stand-by diesel engines/generator

3.8 Regulations for Biosolids Management

All solids generated within the JOS are processed at the JWPCP. The disposal of solids and beneficial use of biosolids are subject to federal and state regulations. Depending upon the type and level of treatment provided, solids/biosolids are placed into different classifications, which determine allowable uses of these materials.

3.8.1 Federal Regulations

The EPA promulgated 40 CFR Part 503 in 1993 to establish general requirements, pollutant limits, management practices, and operational standards for the final use or disposal of biosolids. *Biosolids* are sewage sludges/solids that have been treated/stabilized to a degree suitable for beneficial use. Part 503 of 40 CFR contains regulations for biosolids management options, such as land application, surface disposal, and incineration. The regulations classify biosolids as Exceptional Quality, Class A, or Class B biosolids. Sludges that do not fulfill the requirements for any classification are termed *unclassified solids*.

Unclassified solids generated at the JWPCP are typically managed via surface disposal (i.e., landfilled). Pathogen and vector attraction reduction requirements are also included in 40 CFR Part 503. POTWs

with a design flow rate greater than or equal to 1.0 MGD and POTWs serving 10,000 people or more must comply with monitoring and reporting provisions outlined by the EPA in this regulation. The JWPCP produces Class B biosolids and is subject to the regulatory requirements of Class B biosolids, which are discussed in Section 3.8.1.1.

3.8.1.1 Class B Requirements

Class B biosolids can be applied to agricultural fields and other areas that are not accessible to the general public. The biosolids producer is responsible for monitoring how the biosolids are applied at the point of use and for compliance with all regulations at the point of use. The pollutant concentration limits that determine the reuse and disposal options for biosolids from 40 CFR Part 503 are listed in Table 3-16.

Table 3-16. Pollutant Concentration Standards for Biosolids

Constituent	Ceiling Concentration ^a (mg/kg)	Monthly Average Concentration ^b (mg/kg)	Cumulative Pollutant Loading Rate ^b (kg/ha)
Arsenic	75	41	41
Cadmium	85	39	39
Copper	4,300	1,500	1,500
Lead	840	300	300
Mercury	57	17	17
Molybdenum	75	-	-
Nickel	420	420	420
Selenium	100	100	100
Zinc	7,500	2,800	2,800

^a The maximum concentration at which biosolids may be given away or sold for land application.

^b Dry weight basis.

mg/kg = milligrams per kilogram

kg/ha = kilograms per hectare

Source: EPA, 40 CFR 503 – Standards for the Use or Disposal of Sewage Sludge 1997

3.8.2 State Regulations

The SWRCB enacted State Water Quality Order No. 2000-10-DWQ in August 2000, which was later replaced by State Water Quality Order No. 2004-0012-DWQ, to establish general WDRs for the reuse of biosolids. The land application requirements are more restrictive than those contained in 40 CFR Part 503 and are designed to account for conditions specific to California soils and local environments through the issuance and oversight of general order permits.

3.9 Regulations for Hazardous Materials

3.9.1 Federal Regulations

The EPA is the principal federal agency regulating hazardous materials. As such, the EPA broadly defines a hazardous waste as one that is specifically listed in EPA regulations, that has been tested and meets one of the characteristics (e.g., toxicity) established by the EPA, or that has been declared hazardous by the generator based on its knowledge of the waste. In general, federal regulations applicable to hazardous wastes are contained in Titles 29, 40, and 49 of the CFR. The main federal regulations pertaining to hazardous materials are discussed in the following sections.

3.9.1.1 Resource Conservation and Recovery Act

The Resource Conservation and Recovery Act (RCRA), including the Hazardous and Solid Waste Amendments of 1984 (HSWA), imposes regulations on hazardous waste generators, transporters, and operators of treatment, storage, and disposal facilities (TSDFs). The HSWA also requires the EPA to establish a comprehensive regulatory program for underground storage tanks.

3.9.1.2 Comprehensive Environmental Response, Compensation, and Liability Act

The Comprehensive Environmental Response, Compensation, and Liability Act (CERCLA), also known as Superfund, establishes a comprehensive national program to identify active and abandoned waste disposal sites that pose a threat to human health or the environment. CERCLA created a fund to pay for the cleanup of abandoned sites for which no responsible parties could be identified.

3.9.1.3 Superfund Amendment Reauthorization Act

The Superfund Amendment and Reauthorization Act Title III (community right-to-know laws) is the set of statutes that grants individuals information regarding chemicals located in their communities or workplace and that provides emergency preparedness for reaction to environmental accidents.

3.9.1.4 Hazardous Materials Transportation Act

The Hazardous Materials Transportation Act governs the transportation of hazardous materials. These regulations are promulgated by the United States Department of Transportation and enforced by the EPA. The California Environmental Protection Agency (Cal-EPA) has been granted primary responsibility by the EPA for administering and enforcing hazardous materials management plans. In particular, the state has acted to regulate the transfer and disposal of hazardous waste. Hazardous waste haulers are required to comply with regulations that establish numerous standards, including criteria for handling, documenting, and labeling the shipment of hazardous waste (26 CCR 25160 et seq.). Hazardous waste TSDFs are also highly regulated and must meet standard criteria for processing, containment, and disposal of hazardous materials (26 CCR 25220).

3.9.2 State Regulations

Cal-EPA defines a hazardous material more generally as a material that, because of its quantity, concentration, or physical or chemical characteristics, poses a significant present or potential hazard to human health and safety or to the environment if released (26 CCR 25501). Note that hazardous materials include raw materials and products, such as bulk chemicals stored for the operation of a typical POTW.

California state regulations governing hazardous materials are as stringent as, or in some cases, more stringent than, federal regulations. State regulations include requirements for detailed planning and management to ensure that hazardous materials are properly handled, stored, and disposed of in order to reduce human health risks.

3.9.2.1 Hazardous Materials Release Response Plans and Inventory Act

The Hazardous Materials Release Response Plans and Inventory Act (also known as the Business Plan Act) requires a business using hazardous materials to prepare a plan describing the facility, inventory,

emergency response plans, and training programs. The Sanitation Districts prepare this plan biennially and submit it to the Los Angeles County Fire Department, Hazardous Materials Division.

3.9.2.2 Hazardous Waste Control Act

The state equivalent of RCRA is the Hazardous Waste Control Act (HWCA). The HWCA created the State Hazardous Waste Management Program, which is similar to the RCRA program but is generally more stringent. The HWCA establishes requirements for the proper management of hazardous substances and wastes with regard to criteria for (1) identification and classification of hazardous wastes; (2) generation and transportation of hazardous wastes; (3) design and permitting of facilities that recycle, treat, store, and dispose of hazardous wastes; (4) treatment standards; (5) operation of facilities; (6) staff training; (7) closure of facilities; and (8) liability requirements.

3.9.2.3 Emergency Services Act

Under the California Emergency Services Act, the state developed an emergency response plan to coordinate emergency services provided by all governmental agencies. The plan is administered by the California Office of Emergency Services (OES). OES coordinates the responses of other agencies, including the EPA, the Federal Emergency Management Agency, the California Highway Patrol, the RWQCBs, the air quality management districts, and the county disaster response offices. Local emergency response teams, including the fire, police, and sheriff's departments, provide most of the services to protect public health.

3.10 Regulations for Environmental Impacts

3.10.1 Federal Regulations

3.10.1.1 National Environmental Policy Act

NEPA, enacted in 1970, was developed in response to a national sentiment that federal agencies should take more direct responsibility in providing greater protection for the environment. NEPA is the nation's basic charter for the protection of the environment. It establishes environmental policy for the nation, provides an interdisciplinary framework for federal agencies to prevent environmental damage, and contains procedures to ensure that federal agency decision-makers take environmental factors into account (Bass and Herson 1996).

The four main purposes of NEPA include:

- Declare a national policy that will encourage productive and enjoyable harmony between people and the environment
- Promote efforts that will prevent or eliminate damage to the environment and biosphere and stimulate health and welfare
- Enrich the understanding of the ecological system and natural resources important to the nation
- Establish a Council on Environmental Quality

NEPA applies to all federal agencies and most of the activities they manage, regulate, or fund that affect the environment. Under NEPA, the lead agency is the federal agency with the primary responsibility for complying with NEPA for a proposed action. To construct the new or modified ocean discharge system

being evaluated in the Clearwater Program Master Facilities Plan (MFP), the Sanitation Districts would need to secure permit(s) from the Corps under one or more of the following federal acts:

- Section 404 of the CWA, which regulates fill or discharge of materials into state and ocean waters
- Section 10 of the Rivers and Harbors Act, which regulates the diking, filling, and placement of structures in navigable waterways
- Section 103 of the Marine Protection, Research, and Sanctuaries Act, which regulates the transportation of dredged material for the purpose of dumping it into ocean waters

Therefore, the Corps is the federal lead agency for the federal action under NEPA.

3.10.2 State Regulations

3.10.2.1 California Environmental Quality Act

CEQA, enacted in 1970, was modeled after NEPA. CEQA applies to all proposed discretionary activities that will be carried out or approved by California public agencies, such as the Sanitation Districts, unless such activities are specifically exempted. Under CEQA, a lead agency has the principal discretionary responsibility to approve a project and, therefore, is the agency with the primary responsibility for preparing a CEQA document associated with a proposed discretionary action. For the MFP EIR, the Sanitation Districts will serve as the CEQA lead agency.

The purpose of CEQA is to minimize environmental damage. The primary objectives of CEQA are to (1) disclose to decision makers and the public the significant environmental effects of a proposed project to enable them to consider its environmental consequences and (2) to balance the benefits of a project with the environmental costs.

Major elements of CEQA include:

- Disclosing environmental impacts
- Identifying and preventing environmental damage
- Fostering intergovernmental coordination
- Enhancing public participation
- Disclosing agency decision making (Bass et al. 1996)

3.11 Regulations for Endangered Species

3.11.1 Federal Regulations

3.11.1.1 Federal Endangered Species Act

The Federal Endangered Species Act (FESA) regulates the take of species listed as threatened or endangered. *Take* is broadly defined as to harass, harm, pursue, hunt, shoot, wound, kill, trap, capture, or collect, or to attempt to engage in any such conduct. Consultation with the United States Fish and Wildlife Service (USFWS) and the National Marine Fisheries Service (NMFS) may be required under FESA for implementation of the Clearwater Program.

Section 7

Section 7 of FESA applies when a project involves a federal action such as issuing a federal permit or federal funding. Section 7 requires the federal agency to consult with the USFWS and/or NMFS regarding the potential effect of the agency's action on those species listed as threatened or endangered. Section 7 compliance also applies to agencies applying for SRF loans because some of the funding is from federal sources. This consultation typically results in preparation of a biological opinion that specifies whether the proposed action is likely to jeopardize the continued existence of the listed species or result in adverse modification of critical habitat. The biological opinion may include an incidental take statement if the proposed action would result in the take of a listed species incidental to the federal action.

Section 9

Section 9 of FESA prohibits all persons subject to the jurisdiction of the United States from taking, importing, exporting, transporting, or selling any fish or wildlife species listed as endangered or threatened.

Section 10

Although Section 9 prohibits the take of a federally listed species, Section 10 of FESA is the mechanism that may allow an incidental take of such species. The USFWS may issue a take permit for any taking that is incidental to, and not for the purpose of, carrying out an otherwise lawful activity. Along with the application for an incidental take permit, the applicant must submit a conservation plan that specifies likely impacts that would result from the take, mitigation measures to minimize those impacts, funding for the mitigation, and a project alternatives analysis.

3.11.2 State Regulations

3.11.2.1 California Endangered Species Act

Under the California Endangered Species Act (CESA), all state lead agencies (as defined by CEQA) preparing initial studies, negative declarations, or EIRs must consult with the California Department of Fish and Game (CDFG) to ensure that any action authorized, funded, or carried out by that lead agency is not likely to jeopardize the continued existence of any endangered or threatened species. This CESA consultation requirement does not apply to local lead agencies, such as the Sanitation Districts.

Section 2080 of CESA prohibits any party from importing into the state, exporting out of the state, or taking, possessing, purchasing, or selling within the state any part or product of any endangered or threatened species (except as provided in the Native Plant Protection Act or California Desert Native Plants Act). Through Section 2081 of CESA, CDFG may enter into a management agreement with the project applicant to allow for an incidental take, as the USFWS and NMFS may under Section 10 of FESA. Under CESA, *take* is defined as to hunt, pursue, catch, capture, or kill, or attempt to hunt, pursue, catch, capture, or kill.

3.11.2.2 California Fish and Game Code

Sections 1601–1616 of the California Fish and Game Code apply to any state or local government agency or any public utility that proposes to

substantially divert or obstruct the natural flow of, or substantially change or use any material from the bed, channel, or bank of, any river, stream, or lake, or deposit or dispose of debris, waste, or other material containing crumbled, flaked, or ground pavement where it may pass into any river, stream, or lake.

Sections 1601–1616 require application to the CDFG to obtain a Streambed Alteration Agreement (SAA). This agreement is negotiated between the CDFG and the applicant. The agreement may contain mitigation measures, such as erosion control, intended to reduce the effect of the activity on fish and wildlife resources. The agreement may also include monitoring to assess the effectiveness of the proposed mitigation measures.

3.11.3 Local Regulations

3.11.3.1 Significant Ecological Areas

Significant ecological areas (SEAs) were developed by the Los Angeles County Department of Regional Planning (DRP) as a way to protect biotic diversity, including habitat for endangered species. In 1972, the original SEA report was prepared and submitted to the DRP to be used as background information for the 1973 County of Los Angeles General Plan. A second SEA study, completed in 1976 and amended in the 1980 County of Los Angeles General Plan, identified 61 SEAs within the county. The most recent SEA study, completed in 2001 and amended in the 2035 County of Los Angeles General Plan, identifies 31 SEAs within the county, several of which are combinations of previous SEAs.

Although SEAs do not preclude development or construction, they promote open space conservation. SEAs require another level of scrutiny in the CEQA review process by the Significant Ecological Areas Technical Advisory Committee (SEATAC). SEATAC reviews proposed projects to ensure consistency with SEA-recommended management practices before a SEA conditional use permit (CUP) can be issued and the project can be approved.

The Sanitation Districts could be required to obtain a CUP for construction of new facilities within a proposed SEA if the SEA is currently in place or is adopted prior to the start of construction of any proposed JOS facilities.

3.12 Regulations for Cultural Resources

3.12.1 Federal Regulations

3.12.1.1 National Historic Preservation Act

A programmatic agreement between the SWRCB and the State Historic Preservation Officer (SHPO) requires that projects receiving federal funds administered by the SWRCB (such as SRF loan funding) comply with Section 106 of the National Historic Preservation Act (NHPA). Because the Sanitation Districts may seek to finance projects associated with the Clearwater Program MFP with SRF loan funds, compliance with Section 106 of the NHPA would be required. In addition, Section 106 compliance would be required because federal permits are required for the ocean work being proposed under the Clearwater Program.

The Section 106 review process is implemented by means of a five-step procedure including: (1) the identification and evaluation of historic properties, (2) an assessment of the effects of the undertaking on properties that are eligible for listing on the National Register of Historic Places, (3) a consultation with the SHPO and other agencies for the development of an agreement that addresses the treatment of historic properties, (4) the receipt of comments on the agreement or results of the consultation from the Advisory Council on Historic Preservation, and (5) project implementation subject to conditions imposed by the consultation and any agreements.

3.12.2 State Regulations

The state requirements for cultural resources are outlined in Sections 5020 through 5024.6, 21084, and 21084.1 of the California Public Resources Code (CPRC). In general, compliance with the requirements of Section 106 of the NHPA is sufficient to ensure compliance with CEQA.

Other state requirements are outlined in Section 7050.5 through 7055 of the CHSC and Sections 5097 through 5097.998 of the CPRC, which provide for the protection of Native American remains and identify special procedures to be followed when Native American burial sites are found. When remains are found, the Native American Heritage Commission (NAHC) and the County Coroner must be notified. The NAHC provides guidance concerning the most likely Native American descendants and the treatment of human remains and associated artifacts. Compliance with the provisions of these laws is separate from the requirements of the NHPA and CEQA.

3.13 Other Agencies Associated With Tunneling and Marine Construction

A new or modified ocean discharge system for JWPCP effluent is evaluated in this MFP. Associated regulatory agencies that have not been previously discussed in this chapter are identified in the following sections.

3.13.1 Federal Agencies

3.13.1.1 U.S. Coast Guard

Under 33 CFR Part 66, the U.S. Coast Guard issues private aids to navigation for temporary or permanent stationing of a fixed or floating object within navigable waters of the U.S.

3.13.2 State Agencies

3.13.2.1 California Coastal Commission

The California Coastal Commission (CCC) retains coastal permit jurisdiction over projects located on public trust lands, tidelands, and submerged lands, extending inland generally 1,000 yards from the mean high tide line (with additional considerations for areas with estuarine, habitat, or recreational significance) to 3 nautical miles offshore. A project that involves outfall construction within state of California waters (i.e., seaward from the mean high tide line to 3 nautical miles offshore, measured from the harbor breakwater) requires issuance of a permit from the CCC. The federal government administers the submerged lands, subsoil, and seabed lying between the seaward extent of the state's jurisdiction and the seaward extent of federal jurisdiction, which extends from 3 to 200 miles offshore.

Pursuant to Section 307(c)(3)(A) of the Coastal Zone Management Act (CZMA), any federally licensed or permitted activity affecting any land or water use or natural resource in the coastal zone must be consistent with state coastal management policies. The CCC, which is responsible for implementing the CZMA in California, issues concurrence in a certification to the permitting agency that the project would be conducted consistent with California's approved coastal management program. For the portion of the project that lies within state waters, the consistency certification is redundant as the coastal development permit serves as the consistency certification.

3.13.2.2 California State Lands Commission

The state of California acquired sovereign ownership of all its tidelands and submerged lands upon its admission to the U.S. in 1850. The California State Lands Commission (CSLC) was established in 1938 under Division 6 of the CPRC to provide stewardship of state's tidelands and submerged lands through economic development, protection, preservation, and restoration. The CSLC also retains residual and review authority for tidelands and submerged lands legislatively granted in trust to local jurisdictions. CSLC jurisdiction extends seaward from the mean high tide line to 3 nautical miles offshore.

3.13.2.3 California Department of Industrial Relations

Tunnel safety is overseen by the California Occupational Safety and Health Administration (Cal/OSHA), Mining and Tunneling Unit. Regulations are outlined in Title 8, CCR, Chapter 4, Subchapter 17, Article 4, and Subchapter 20, Article 3.

3.14 Other Applicable Laws and Regulations

3.14.1 Federal Regulations

3.14.1.1 State Revolving Fund

Other applicable laws and regulations that apply to the MFP include federal requirements in accordance with the SRF loan program beyond those of FESA and NHPA. These requirements are described in the sections that follow.

Executive Order 11988

This executive order relating to floodplain management was prepared in 1979 to avoid, to the extent possible, long- and short-term adverse impacts associated with the occupation and modification of floodplains and to avoid direct or indirect support of development in floodplains. This order requires that the agency reviewing the proposed action consider alternatives to avoid adverse effects and incompatible development in floodplains. If the only practicable alternative is to site a project in the floodplain, and the reviewing agency concurs, then the action must be designed or modified to minimize potential harm to the floodplain. Furthermore, a notice containing an explanation of why the proposed action is to be located in the floodplain must be prepared and circulated.

Executive Order 11990

This executive order was prepared to avoid direct or indirect support of new construction in wetlands wherever there is a practicable alternative. The order requires early public review of any plans or proposals for new construction in wetlands, in addition to notification of the federal Office of Management and Budget regarding compliance with the order. The order establishes several factors that should be considered during evaluation of the effects of a project on the survival and quality of wetlands including public health and welfare, maintenance of natural systems, and other uses of wetlands in the public interest.

Executive Order 11593

This executive order provides for the protection and enhancement of the cultural environment. Compliance with Section 106 of NHPA and with CEQA fulfills the requirements of this order.

Executive Order 12898

This executive order effectively expands the scope of complaints that may be filed with EPA under Title VI of the Civil Rights Act of 1964 to include issues of environmental justice. Environmental justice complaints typically allege that facilities generating adverse impacts associated with pollution and/or potential pollution are systemically sited in and/or permitted to operate in minority communities. Disproportionate adverse impacts on minority communities associated with pollution generated by facilities may constitute discrimination. Executive Order 12898 directs the EPA to address environmental justice concerns through the permitting process and applies to the permitting decisions of all agencies that receive or act as a conduit for federal monies.

The EPA's Title VI regulations apply to all programs and activities carried out by departments or agencies that receive EPA funding either directly or indirectly. The SWRCB administers a number of funding programs, including SRF, which are partially funded by federal monies. The SWRCB has delegated permitting authority vested in it by state and federal laws to the local RWQCBs, including the LARWQCB. Accordingly, all of the permitting decisions of the LARWQCB, including the issuance, modification, or renewal of the WDRs for the JOS facilities, are subject to the mandates of Executive Order 12898 and the EPA guidelines implementing that order.

3.14.2 State Regulations

3.14.2.1 Worker Safety

Worker safety laws protect public health in the workplace. These laws are administered and enforced by Cal/OSHA. The laws apply to normal operational activities and include all provisions for standard injury and illness prevention, construction requirements, and requirements for the handling of chemicals and prevention of infection and disease. Worker safety programs directly benefit public health by reducing the number of accidents and injuries that occur. Worker safety laws also protect worker and public safety by requiring specific training, handling, transportation, and storage procedures for hazardous materials.

3.14.3 Local Regulations

3.14.3.1 Storm Water Pollution Prevention Plan

A storm water pollution prevention plan (SWPPP) is generally required as part of a construction permit for large projects or facilities that are within a drainage basin of a water of the U.S. The major objectives of a SWPPP are to help identify sources of sediment and other pollutants that affect the quality of storm water discharges and to describe and ensure implementation of best management practices (BMPs). The SWPPP emphasizes the use of appropriately installed and maintained storm water pollution reduction BMPs.

Required elements of a SWPPP include:

- A site description addressing the elements and characteristics specific to the site
- BMPs for erosion and sediment controls
- BMPs for construction waste handling and disposal
- Implementation of approved local plans
- Proposed post-construction controls, including a description of local post-construction erosion and sediment control requirements

- Non-stormwater management
- Routine visual inspections
- Development of a Construction Site Monitoring Plan

Chapter 4

WATER, WASTEWATER, AND PROJECTIONS

4.1 Introduction

This chapter provides a comprehensive overview of regional water supply and demand as well as Joint Outfall System (JOS) wastewater characteristics and flow projections, solids projections, and water reuse.

4.2 Water Use

Water use includes withdrawals from surface and groundwater supply sources, deliveries to meet water demands, releases from points of use, and returns to surface water and groundwater supply sources.

4.2.1 Historical Water Use

The availability of fresh water has proven critical for commercial and residential development in the Los Angeles metropolitan area, including the JOS service area. Throughout the history of the region, major efforts have been implemented to supply a growing population and industrial base with adequate amounts of water.

Early in the 20th century, when it became apparent that local water supplies were not sufficient to support continued development of the Los Angeles region, the city of Los Angeles began to import water from the Owens Valley in Northern California. Later, water was diverted from the Colorado River, and more recently, the state of California began delivering water from the Sacramento-San Joaquin Delta in Northern California.

Extensive water supply infrastructure, including aqueducts, pumping plants, storage reservoirs, and treatment plants, has been constructed to deliver water from these regions, and additional water supply infrastructure is planned to improve the reliability of Southern California's imported water supplies. Despite the efforts to date, the effects of the recent droughts and projections of growth in the region indicate that water supply will continue to be a critical issue in Southern California and the JOS planning area in the future.

4.2.2 Significance to Clearwater Program Facilities Planning

The Sanitation Districts of Los Angeles County (Sanitation Districts) have consistently pursued a program of wastewater reclamation and reuse since 1963. Recycled water generated at the JOS water reclamation plants (WRPs) supports a variety of beneficial uses including landscape and agricultural irrigation, industrial cooling and process water, and groundwater recharge operations. As water resources become scarcer in response to rising demands and declining supplies, demand for recycled water in Southern California will likely increase.

The reuse potential of recycled water is directly influenced by the quality of the water supply. Conventional wastewater treatment processes, such as those employed at the JOS WRPs, have a minimal effect on certain water quality parameters, including mineral content. The mineral content of the water supply, generally expressed in terms of the concentration of total dissolved solids (TDS), is a parameter of concern to the Sanitation Districts. High TDS levels in the water supply produce high TDS levels in recycled water, which tends to limit available reuse options.

Excessive TDS levels in recycled water can be detrimental to some plant species and, therefore, limit irrigation applications. In addition, the TDS limit for recycled water used for groundwater recharge at the Montebello Forebay, the Sanitation Districts' single largest user of recycled water, has been set at 700 milligrams per liter (mg/L). The quality of the water supply, especially its TDS level, is, therefore, relevant to the Sanitation Districts' facilities planning.

The viability of continued wastewater recycling and reuse depends on the delivery of a high quality water supply to the regions served by the WRPs. The Sanitation Districts are committed to working with the communities using the recycled water to achieve cost-effective treatment upgrades as required to support increased reuse of this important resource. This would be accomplished within a framework that maintains consistency with regional salinity management plans.

4.3 Existing Water Supply

This section discusses the various sources of water supply for the JOS service area, and the impacts of these sources on the Sanitation Districts' facilities planning. Water supplies for the JOS service area are composed of local and imported water resources. Local water resources consist primarily of groundwater, but may also include surface water and recycled water. Imported water resources, which constitute approximately three-quarters of the JOS water supply, are provided by the Metropolitan Water District of Southern California (MWD) via the Colorado River Aqueduct and the California Aqueduct.

4.3.1 Imported Water

The MWD is a consortium of 26 cities and water districts that provides drinking water to approximately 19 million people in parts of Los Angeles, Orange, San Diego, Ventura, Riverside, and San Bernardino Counties. Organized in 1928 following the adoption of the Metropolitan Water District Act by the California Legislature in 1927, the MWD currently delivers 1.7 billion gallons of water per day to its 5,200 square mile service area. The MWD imports water from two sources: the Colorado River via the Colorado River Aqueduct, and Northern California via the State Water Project's (SWP's) California Aqueduct.

The MWD was originally formed with the intent to build and operate an aqueduct to import water to Southern California from the Colorado River. Imported water from the Colorado River was designated to supplement local water supplies in the original 13 MWD member cities. The 242-mile Colorado River Aqueduct was completed in 1941 and began deliveries of Colorado River water to Southern California the same year.

In 1951, the California Legislature authorized construction of the Feather River Project, now known as the SWP, by the State Department of Water Resources. The purpose of the SWP is to transfer surplus water from Northern California to water-scarce regions in Central and Southern California. In 1972, the MWD began providing additional imported water via the SWP to meet increased demands in its service area.

4.3.1.1 Colorado River Water

Colorado River water supplies generally exhibit low levels of most water quality constituents. However, mineral concentrations of water delivered via the Colorado River Aqueduct have typically been high.

Mineralization of Colorado River waters occurs naturally as water tributary to the river flows over and through soils within the watershed and as soluble salts are released through natural geologic weathering processes. Farming activities along the Colorado River also contribute significant amounts of salts to river water. Water imported via the Colorado River Aqueduct has the highest level of salinity of all of the MWD's sources of supply, averaging 630 mg/L.

The MWD has employed a number of strategies to avoid potential problems associated with the higher mineral content of the Colorado River Aqueduct supply source and contamination-related issues. To lower TDS levels in water supplies derived from the Colorado River, the MWD typically blends Colorado River water with SWP water that is lower in TDS.

Another compound of concern found in water from the Colorado River Aqueduct is perchlorate. Perchlorate enters the Colorado River system at the Las Vegas wash near Henderson, Nevada. The MWD has adopted the Perchlorate Action Plan to proactively address this issue. As a result, the amount of perchlorate entering the Colorado River system from Henderson has been reduced from approximately 900 pounds per day (lbs/d) in 2000 to 77 lbs/d as of February 2008.

The MWD provides treated water to the JOS service area through three treatment facilities: the Jensen Filtration Plant, located in the northwestern end of the San Fernando Valley; the Weymouth Filtration Plant, located in the northeastern end of the San Gabriel Valley; and the Diemer Filtration Plant, located in the northwest corner of Orange County. These facilities have been interconnected into a distribution loop whereby any of the three facilities may potentially provide water to the JOS service area.

In general, however, the Jensen Plant serves the San Fernando Valley, the city of Los Angeles, and the South Bay area (e.g., Redondo Beach, Torrance); the Weymouth Filtration Plant serves the San Gabriel Valley and the southeastern and central portions of the Los Angeles Basin; and the Diemer Filtration Plant serves Orange County. Treated water from the Jensen Filtration Plant is derived solely from SWP water; treated water from the Weymouth and Diemer Filtration Plants is derived from a blend of SWP and Colorado River water.

4.3.1.2 State Water Project

Potable water provided by the SWP flows through the Sacramento-San Joaquin Delta (Delta). Measurements by the Department of Water Resources and municipal agencies that treat and deliver SWP water indicate that concentrations of water quality constituents are generally low with respect to drinking water standards. TDS levels in SWP water are also relatively low. Water supplies from the SWP have average TDS concentrations of 250 mg/L for water supplied through the East Branch and 325 mg/L from the West Branch. SWP water delivered by the California Aqueduct has an average TDS concentration of 310 mg/L.

Treated SWP water has occasionally exceeded existing state and federal drinking water standards for trihalomethanes (THMs). THMs are a by-product of disinfection processes that employ chlorine as a disinfectant. They are suspected human carcinogens and are, therefore, regulated by state and federal safe drinking water laws. THMs form when halogens, such as chlorine and bromine, react with dissolved organic matter present in water.

SWP water contains relatively high levels of naturally occurring organic matter, measured as total organic carbon (TOC), due to the influence of peat soils in the Delta. The presence of bromides in SWP water as a result of the ocean's influence on the Delta allows the formation of bromine-containing THM compounds during chlorine disinfection.

To protect and improve the water quality of SWP supplies and resolve environmental issues, the MWD is one of the agencies that have implemented the CALFED Bay-Delta Program. The CALFED Bay-Delta Program has set water quality goals for TOC and bromide using a cost-effective combination of alternative source waters, source control, and treatment technologies. Measures have included the use of ozonation to disinfect SWP waters and a blending of SWP water or Colorado River water to lower the concentration of THMs.

4.3.2 Local Surface Water

The JOS service area includes two major river systems, the Los Angeles and San Gabriel Rivers, and several large creek systems. Some precipitation in the areas tributary to these rivers and creeks compliments local water supply through groundwater recharge and incidental runoff into surface storage reservoirs further up in the watershed. However, flood control is the primary function of the mostly concrete lined river and stream systems. Because most of the local surface water drains directly to the ocean through concrete storm drains and channels, local surface water quality does not have a significant impact on the JOS service area.

4.3.3 Groundwater

The groundwater basins that provide water to the JOS service area include the Central, West Coast, Main San Gabriel, Raymond, Claremont Heights, Live Oak, Puente, Spadra, and Pomona Basins. With the exception of the Puente and Spadra Basins, the water quality in these basins is generally good. Where contamination does occur, it tends to be highly localized. The most common contaminants are industrial solvents and nitrates.

In contrast to the other water quality basins, contamination of the Main San Gabriel Basin is fairly widespread. The Main San Gabriel Basin has been classified as a Superfund site by the United States Environmental Protection Agency (EPA). Chlorinated solvents are the most common contaminants found in this basin; nitrate and metals concentrations are also high in some locations. Remediation is underway to improve the groundwater quality in the Main San Gabriel Basin.

Groundwater from all of the basins generally exhibits low concentrations of TDS with a few exceptions. In coastal groundwater basins, TDS levels are highly elevated in locations of historic overdrafting and subsequent saltwater intrusion. Freshwater injection barrier wells have been employed at many of these locations to prevent further degradation of the groundwater aquifers. TDS levels are also elevated in regions affected by irrigated agriculture, dairy or livestock activities, and septic tanks in unsewered areas. TDS levels are also elevated in portions of coastal basins where saltwater intrusion has occurred. One strategy to prevent further degradation of these aquifers is the installation of freshwater-injection barrier wells.

4.3.4 Recycled Water

Another source of water supply is recycled water. Approximately one-third of the wastewater in the JOS is treated at the WRPs and is available for reuse. The remaining two-thirds is treated at the Joint Water Pollution Control Plant (JWPCP) for ocean disposal, as the tributary wastewater flow to this plant is too

high in TDS for reuse without advanced treatment. Recharge and reuse TDS permit limits for the water recycling plants in the JOS range from approximately 600 to 1,150 mg/L. Recycled water quality and water reclamation permits are discussed in Chapter 3.

Wastewater flows experience significantly higher salinity concentrations than the potable water supply. Typically, each cycle of urban water use adds 250 to 400 mg/L of TDS to the wastewater. Salinity increases tend to be higher where specific commercial, industrial, or agricultural processes add brine wastes to the discharge stream or where brackish groundwater infiltrates into the sewer system.

Where wastewater flows have high salinity concentrations, the use of recycled water may be limited or additional treatment may be required. Landscape irrigation and industrial reuse become problematic at TDS concentrations of over 1,000 mg/L. Some crops are particularly sensitive to high TDS concentrations, and the use of high-salinity recycled water may reduce yields of these crops. In addition, concern for the water quality in groundwater basins may lead to restrictions on the use of recycled water on lands overlying those basins.

These issues are exacerbated during times of drought, when the salinity of imported water supplies increases. As a result, there is an increase in the salinity of wastewater flows and, therefore, a similar increase in recycled water salinity. Basin management plans may restrict the use of recycled water by recycled water customers when its use would be most valuable. Therefore, to maintain the cost-effectiveness of recycled water, the salinity level of the region's potable water sources and wastewater flows must be properly managed.

4.4 Projected Water Demand

4.4.1 Municipal Water Demand

The MWD Regional Urban Water Management Plan (UWMP) includes demand projections for the MWD service area, which includes the JOS service area. According to the MWD's 2005 UWMP, historical retail water demands in the Los Angeles County portion of the MWD's service area increased from 1.5 million acre-feet (AF) in 1980 to approximately 1.8 million AF in 2005. Due to the recession, wet weather, conservation efforts, and lingering drought impacts, water use dropped for several years in the mid-1990s. Following the pattern of population projections, water demands are projected to increase in Los Angeles County 272,600 AF by the year 2030. The UWMP only contains projections through the year 2030.

Almost 100 percent of Los Angeles County water is used for municipal and industrial (M&I) purposes. Residential water use accounts for the majority of the MWD's M&I demands. Although single-family homes account for about 55 percent of the total occupied housing stock, they account for about 70 percent of total residential water demands. Also, single-family households tend to have more persons living in the household, are likely to have more water-using appliances and fixtures, and tend to have a greater amount of landscaping per home.

4.4.2 Other Water Demand

Commercial, industrial, and institutional (CII) water use represents about 25 percent of the total M&I demands in Los Angeles County. The CII (nonresidential) sector represents water that is used by businesses, services, government, institutions (such as hospitals and schools), and industrial (or manufacturing) establishments. Within the commercial/institutional category, the top water users include schools, hospitals, hotels, amusement parks, colleges, laundries, and restaurants. In Southern California,

the major industrial users include electronics, aircraft, petroleum refining, beverages, and food processing.

4.4.3 Water Conservation

A number of federal and state regulations implemented within the JOS service area encourage water conservation. These regulations include plumbing efficiency standards, urban water management, agricultural water management, recycled water reuse, and graywater use. In addition to the state and federal programs, there are local water conservation programs, and some water agencies use a tiered rate structure to encourage water conservation.

The MWD water demand forecasts discussed in Section 4.4.1 account for water savings resulting from plumbing codes, price effects, and actual implementation of best management practices (BMPs). The MWD total M&I water demand projections achieved an 11 percent savings (measured from 1990 usage levels) from conservation and pricing policies in 2000. It is projected that this level will increase to a 19.3 percent savings in 2030, compared to demands without conservation for the entire MWD service area.

4.5 Future Water Demand and Supply Balance

In the 1990s, resource constraints resulting from drought and operational constraints resulting from regulatory requirements impacted the reliability of the MWD's water supplies while the region experienced accelerated growth. To address this challenge, the MWD and its member agencies collaborated on an Integrated Resource Planning (IRP) process to determine the appropriate level of supply reliability and to establish cost-effective approaches towards achieving that goal.

The reliability evaluation conducted as part of the 1996 IRP process revealed that without future investments in local and imported supplies, the region may experience a supply shortage of at least 0.79 million AF about 50 percent of the time (or once every other year) by 2020. Since 1996, the MWD, its member agencies, and other local agencies have strived to implement the goals identified in the IRP. Implementation and refinements to the IRP are conducted via annual reports to the MWD Board of Directors, as well as an IRP Report update every 5 years (in conjunction with the Regional UWMP update). The IRP updates have confirmed that these efforts have moved the region toward its goal of long-term regional water supply reliability.

The 2004 IRP Update emphasized conservation and local water supply development and included a "planning buffer" as redundancy to accommodate unforeseen circumstances. The 2010 IRP Update, which remained true to the original IRP goal of meeting "full service demands at the retail level under all foreseeable hydrologic conditions," managed recent dramatic changes such as reduced water supply from the Colorado River and more stringent regulations that reduce water supply from the SWP. One component of the 2010 IRP Update was to establish foundational actions that detail strategies for securing additional water sources if changed conditions turn dramatic or persistent. These foundational actions, which will span an estimated 8 years, include low-risk actions (i.e., feasibility studies, legislative efforts, public and stakeholder outreach, agency consultation for permitting, and research) undertaken to reduce the time necessary to make a project operational. The MWD will employ these foundational actions concurrent with the remaining components of the plan that focus on further development or study of four local resources including recycled water, seawater desalination, stormwater, and graywater (MWD 2010).

The major drivers for the improved supply reliability in the MWD service area have been:

- Conservation
- Water transfers and storage and groundwater management programs within the Southern California region
- Storage programs related to the SWP and the Colorado River
- Local resource planning including desalination, water recycling, and groundwater recovery
- Other water supply management programs outside of the region

4.6 Uncertainties and Possible Effects on Projections

Variables exist beyond the control of the Sanitation Districts that may influence the availability of future water supplies and their usage. These may, in turn, affect future wastewater characteristics and flows. Limitations exist relative to the accuracy of predicting population growth, future water usage, and the resulting wastewater-related projections. Some areas of uncertainty include:

- Future availability of imported water supplies and contingency planning related to potential reductions
- Potential effects associated with the increased use of graywater
- Impacts due to future increased recycled water use
- Impacts due to climate change

The approach to dealing with uncertainties within the planning process is discussed in Section 4.6.5.

4.6.1 Imported Water Supply Contingency Planning

A variety of federal, state, and local programs have been initiated to enhance the supply capabilities and reliability of imported sources to consistently meet projected future demands. In addition, contingency analyses and long-range planning efforts have been undertaken to further improve the supply dependability in coping with potential interruptions or reductions to these sources.

The MWD must meet the drought and water shortage planning requirements of the Urban Water Management Planning Act including:

- Water supply reliability analysis addressing normal, dry, and multiple dry years
- Planning for the stages of actions to implement in response to water supply shortages, accounting for up to a 50 percent reduction in its water supplies

The MWD accomplished this in its Water Surplus and Drought Management Plan (WSDM Plan), which guides planning and operations during both shortage and surplus conditions.

The WSDM Plan identifies the expected sequence of resource management actions that will be executed during surpluses and shortages to minimize the probability of severe shortages and eliminate the possibility of extreme shortages and shortage allocations. Unlike the MWD's previous shortage management plans, the WSDM Plan recognizes the link between surpluses and shortages, and integrates planned operational actions with respect to both conditions.

Through effective management of its water supply, the MWD fully expects to be completely reliable in meeting all non-discounted, non-interruptible demands up to the year 2030. The effectiveness of the MWD's contingency planning approach has been demonstrated by the region's success in dealing with recent operational constraints, including supply disruptions from the Colorado River in 2003 and the SWP in 2004.

The guiding principle of the WSDM plan is to manage the MWD's water resources and management programs to maximize management of wet year supplies and minimize adverse impacts of water shortages to retail customers. From this guiding principle, the MWD developed the following supporting principles:

- Encourage efficient water use and economical local resource programs
- Coordinate operations with member agencies to provide as much surplus water as possible in dry years
- Pursue innovative transfer and banking programs to secure more imported water for use in dry years
- Increase public awareness about water supply issues

The WSDM plan also declared that if mandatory import water allocations are necessary, they would be calculated on the basis of need, rather than historical purchases. The WSDM plan contains the following considerations that would be utilized for an equitable allocation of imported water:

- Impact on retail consumers and regional economy
- Investments in local resources, including recycling and conservation
- Population growth
- Changes and/or losses in local supplies
- Participation in the MWD's non-firm (interruptible) programs
- Investment in the MWD's facilities

4.6.2 Graywater Use

On March 18, 1997, the Building Standards Commission approved the revised California Graywater Standards, as presented in the California Administrative Code, Title 24, Part 5, Appendix G. Graywater is defined within these standards as

...untreated wastewater that has not come into contact with toilet waste. Graywater includes wastewater from bathtubs, showers, bathroom wash basins, clothes washing machines, and laundry tubs, or an equivalent discharge as approved by the Administrative Authority. It does not include wastewater from kitchen sinks, photo lab sinks, dishwashers, or laundry water from soiled diapers.

The use of graywater is limited to subsurface irrigation, and no *surfacing* of graywater is permitted. Surfacing of graywater means the ponding, running off, or other releases of graywater from the land surface. Any connection to a potable system must include an air gap. A permit must be obtained before constructing a graywater system.

The use of graywater systems would result in the replacement of water currently allocated for residential irrigation, thereby reducing the overall demand on potable supplies. Graywater usage would also reduce the hydraulic and organic loading to the sewers generated by residences with these systems in place. Due to the low organic content of graywater, the flows to the sewers would likely be lower in volume but higher in concentration. However, the sewer system would still need to be sized to accept graywater flow because irrigation systems would not be used during periods of sustained precipitation.

4.6.3 Recycled Water Usage

Recycled water provides an important water resource in arid, drought-prone areas, such as Southern California. In 2010, the WRPs within the JOS produced approximately 130 million gallons per day (MGD) of recycled water, of which approximately 50 percent was reused. The major categories of reuse are:

- Groundwater recharge
- Landscape and agricultural irrigation
- Industrial/commercial process water
- Recreational/environmental impoundments

A detailed discussion of the Sanitation Districts' recycled water program is provided in Section 4.10. The use of recycled water can provide a number of societal benefits, including:

- A reduction in the demand of potable, freshwater sources, thereby lessening the need to import water and decrease diversions from sensitive watersheds and ecosystems
- The creation of local, reliable water supplies
- The creation or enhancement of wetlands and riparian habitats
- A potential reduction in energy associated with transporting equivalent volumes of potable supplies into the Los Angeles area and a decrease in the production of associated greenhouse gases
- The generation of economic benefits associated with business retention and attraction that results from a reliable water supply
- The lessening of the need for local water rationing during water emergencies
- The preservation of local quality of life through the maintenance of public greenbelt areas with recycled water, even during droughts and water shortages.

The greater the level of water recycling developed within the JOS, the greater the potential for realizing these benefits. The MWD is the major water purveyor within the area encompassed by the JOS. In recognition of the benefits derived from recycling projects, the MWD has a number of programs that provide financial assistance to its public agency members that promote conservation and recycling.

In addition to the benefits listed previously, some of the specific benefits to the Sanitation Districts associated with the beneficial use of recycled water are:

- Freeing up additional sewer capacity
- Creating a potential source of additional revenue
- Enhancing the public's perception of recycled water

The increased use of recycled water within the JOS would serve to offset the need for additional potable water. Therefore, it could be viewed as accommodating population growth within the system that might otherwise be restricted by limited water resources. It is not anticipated that recycled water use would have a substantive impact on the quantity or quality of wastewater tributary to the sewers.

However, the potential exists that in the future, treatment processes beyond the Sanitation Districts' current systems, such as reverse osmosis (RO), may be implemented to produce higher quality recycled water for specific water recycling projects. This could result in the production of a concentrated brine waste byproduct that would be discharged to the JOS sewers. As with the majority of industrial and high salinity waste streams within the JOS, these brines would likely be routed to sewers directly tributary to the JWPCP. This would result in wastewater flows with a higher concentration of TDS at the JWPCP. However, any brine production that resulted from advance treatment of JWPCP effluent would not likely be returned to the influent flow stream; rather, it would be discharged directly into the plant's ocean outfall system (as is done with brine discharge from the nearby West Basin Municipal Water District's RO plant in Carson).

4.6.4 Climate Change

Water resources are highly sensitive to variations in weather and climate. The accumulation of greenhouse gases in the atmosphere impacts global climate patterns, thereby affecting the availability and quality of freshwater supplies, and altering the frequency and intensity of droughts and floods.

While there is a high degree of certainty that there will be significant changes in the quantity and distribution of precipitation, there are considerable uncertainties associated with the rate at which these changes will take place and the specific nature of the impacts on local hydrologic conditions. In California, climate change may result in significant deviations from patterns observed in the last century, including higher temperatures, reduced Sierra snowpack, earlier snowmelt, less snow and greater rainfall at the higher elevations, and a rise in sea level. The timing and extent of these changes, however, remains uncertain.

In December 2007, the Association of Metropolitan Water Agencies published a report entitled *Implication of Climate Change for Urban Water Utilities*. Included in this report was a summary of the potential direct impacts of climate change on water utilities. A direct impact is defined as an impact resulting from climate change on a water utility's function and operation. An excerpt from this report that includes causes and effects of climate change pertinent to the southwest United States is presented in Table 4-1.

Table 4-1. Climate Change Impacts in the Southwest

Warmer and probably drier overall with more extreme droughts and heat waves
Likely reduced quantities of surface water available from local runoff
Likely reduced quantities of water available to recharge groundwater aquifers
Very likely increased evaporative losses in inter-basin transfers of surface waters
Changes in vegetation of watershed and aquifer recharge areas <ul style="list-style-type: none"> ▪ Altered recharge of groundwater aquifers ▪ Changes in quantity and quality (e.g., TOC, alkalinity) of runoff into surface waters
Increased water temperature <ul style="list-style-type: none"> ▪ Increased evaporation and eutrophication in surface sources ▪ Water treatment and distribution challenges (disinfection, byproducts, regrowth)
Increased water demand <ul style="list-style-type: none"> ▪ Increased irrigation demand ▪ Increased urban demand with more heat waves and dry spells ▪ Increased drawdown of local groundwater resources to meet the above ▪ Increased difficulty of maintaining minimum in-stream flows in surface waters
More intense rainfall events
Increased turbidity and sedimentation <ul style="list-style-type: none"> ▪ Loss of reservoir storage <ul style="list-style-type: none"> ▪ Shallower, warmer water; increased evaporation and eutrophication ▪ Potential conflicts with flood control objectives ▪ Water filtration or filtration avoidance treatment challenges
Increased risk of direct flood damage to water utility facilities

The challenge associated with adjusting to these changes is the development of a strategy and associated infrastructure to provide the volume of water necessary to meet potable water demands at the needed locations and at the time when they are requested. Reduced availability of water supplies could result in higher costs, increased water conservation within residences, and reduced per capita wastewater generation. It is likely water use reductions would also result in a more concentrated wastewater flow.

4.6.5 Responses to Uncertainties in Projections

The degree of uncertainty associated with the prediction of future conditions is a challenge for all planning efforts. The projection of the volumes and characteristics of future wastewater flows depends on a number of factors including:

- Availability and characteristics of future water supplies
- Population growth within the service area
- Wastewater generation rates
- Future commercial and industrial activities

A reasonable set of assumptions has been developed and used to predict future conditions, determine associated needs, develop alternatives to address these needs, and ultimately recommend a plan of action for future implementation.

The key to dealing with uncertainty in recommending future facilities is to incorporate sufficient flexibility that allows for mid-course adjustments to effectively manage unexpected conditions. Systematic monitoring of wastewater flows and characteristics facilitates the staging of improvements based upon imminent identified needs rather than establishing absolute dates for infrastructure improvements. This may result in accelerating the implementation of certain portions of the plan, while

postponing others, such as facility construction. A phased approach would ensure that systems are available when needed while avoiding premature construction of facilities that would result in excess, under-utilized capacity.

4.7 Wastewater Characteristics

To determine the capabilities of the JOS, and to assess future facility needs, the composition of the influent wastewater flow must be quantified. This section examines the physical, chemical, and biological characteristics of recent (2007 to 2009) wastewater flows within the JOS. The properties of recent flows are also compared with historic records and used to project future conditions. Wastewater characteristics were assessed using:

- **Recent Characteristics:** A comprehensive listing, on a plant-by-plant basis, of influent constituents using a 3-year average to provide a representative sampling of recent conditions.
- **Comparison of Recent and Historic Concentrations:** The concentrations of major constituents typically used in the treatment plant assessment are compared using recent concentrations (3-year averages) and past concentrations (1992/93).
- **Comparison of Recent and Historic Loadings:** The mass loadings of major constituents typically used in the treatment plant assessment are compared using recent concentrations (3-year averages) and past concentrations (1992/93).
- **Long-term Concentrations Review:** Information spanning a 20-year timeframe is assessed to identify variations in concentrations over time for major influent constituents.

Information for the 1992/93 timeframe was included to provide a long-term perspective. These values were extracted from the last major facilities planning effort for the JOS, the 2010 Master Facilities Plan (2010 Plan). The La Cañada Water Reclamation Plant (LACAWRP) has been excluded from discussions in this section because it is very small, does not discharge to surface water, and has a fixed tributary area. Wastewater characteristics were determined using data from the Long Beach, Los Coyotes, Pomona, San Jose Creek, and Whittier Narrows WRPs and the JWPCP.

4.7.1 Recent Characteristics

Influent characteristics for the JWPCP and the WRPs of the JOS are presented in Table 4-2. The average values for the listed influent constituents represent a span of calendar years 2007 through 2009.

Concentrations of the majority of wastewater constituents are highest at the JWPCP due to the following:

- The JWPCP receives all primary and secondary solids from the entire JOS
- A greater, higher strength industrial flow is generated in the area directly tributary to the JWPCP
- Poorer quality wastewater is generally routed around the WRPs and sent on to the JWPCP to promote production of the highest quality of recycled water at the WRPs

Table 4-2. JOS Recent Wastewater Characteristics by Treatment Plant (2007–2009 Averages)

Influent Constituent	Units	JOS Treatment Plants					
		POWRP	SJCWRP	WNWRP	LCWRP	LBWRP	JWPCP
Total Flow	MGD	9.3	79.1	6.5	30.3	16.8	295.0
SS	mg/L	356	340	267	315	303	496
Total Cyanide	mg/L	0.0050	0.0038	0.0057	0.0040	0.0050	0.006
Total BOD	mg/L	353	295	229	296	274	426
Total COD	mg/L	738	688	567	634	640	758
TDS	mg/L	576	570	564	837	613	NR
Arsenic	mg/L	0.0021	0.0017	0.0018	0.0025	0.0077	0.0045
Barium	mg/L	0.133	NR	NR	0.055	0.218	NR
Cadmium	mg/L	0.0006	0.0004	0.0003	0.0002	0.0003	0.0022
Total Chromium	mg/L	0.006	0.008	0.009	0.005	0.003	0.030
Copper	mg/L	0.105	0.047	0.064	0.062	0.057	0.144
Lead	mg/L	0.020	0.003	0.003	0.003	0.001	0.009
Mercury	mg/L	0.00028	0.00010	0.00016	0.00009	0.00023	0.00030
Nickel	mg/L	0.015	0.008	0.017	0.007	0.004	0.021
Selenium	mg/L	0.001	0.001	0.001	0.001	0.001	0.010
Silver	mg/L	0.003	0.001	0.001	0.001	0.002	0.003
Zinc	mg/L	0.31	0.08	0.16	0.11	0.14	0.36

Reported TDS concentrations are effluent values.

POWRP = Pomona WRP

SJCWRP = San Jose Creek WRP

WNWRP = Whittier Narrows WRP

LCWRP = Los Coyotes WRP

LBWRP = Long Beach WRP

NR = not recorded

SS = suspended solids

BOD = biochemical (or biological) oxygen demand

COD = chemical oxygen demand

TDS = total dissolved solids

The Sanitation Districts' industrial pretreatment program has effectively limited the presence of trace metals and priority pollutants in the JOS influent flows. Priority pollutants are pollutants for which the EPA must establish ambient water quality criteria and effluent limitations. This program helps ensure that the WRPs can produce recycled water suitable for reuse applications, and that the JWPCP meets stringent ocean discharge requirements.

4.7.2 Recent and Historic Concentrations

The major parameters typically used in the assessment of current plant capabilities and establishing future needs are flow, suspended solids (SS), biochemical (or biological) oxygen demand (BOD), and chemical oxygen demand (COD). These parameters are shown for each plant in Table 4-3. Recent conditions are represented using average data from 2007 through 2009. In addition, the same information from the 2010 Plan, representing fiscal year 1992–93, is presented for historical comparison.

Total flows throughout the JOS decreased slightly over the 15-year span. It should be noted that the influent flows to the Whittier Narrows Water Reclamation Plant (WNWRP) and Pomona Water Reclamation Plant (POWRP) were intentionally reduced by the Sanitation Districts to accommodate nitrogen removal. The wastewater concentration data also indicate that overall wastewater strength has

(1) increased at the POWRP, San Jose Creek Water Reclamation Plant (SJCWRP), WNWRP, and JWPCP, (2) decreased at the Los Coyotes Water Reclamation Plant (LCWRP), and (3) remained relatively unchanged at the Long Beach Water Reclamation Plant (LBWRP).

Table 4-3. Comparison of Recent (2007–2009) and Historical Wastewater Parameters

Influent Constituent	Units	Years	JOS Treatment Plants						JOS Total
			POWRP	SJCWRP	WNWRP	LCWRP	LBWRP	JWPCP	
Total Flow	MGD	1992–1993	12.6	79.0	12.1	31.3	17.6	328.0	480.6
	MGD	2007–2009	9.3	79.1	6.5	30.3	16.8	295.0	437.0
SS	mg/L	1992–1993	245	290	250	449	351	449	409
	mg/L	2007–2009	356	340	267	315	303	496	441
Total BOD	mg/L	1992–1993	229	257	216	325	252	360	330
	mg/L	2007–2009	353	295	229	296	274	426	383
Total COD	mg/L	1992–1993	483	536	458	762	642	794	727
	mg/L	2007–2009	738	688	567	634	640	758	729

SS = suspended solids

BOD = biochemical (or biological) oxygen demand

COD = chemical oxygen demand

MGD = million gallons per day

mg/L = milligrams per liter

4.7.3 Recent and Historic Loadings

Mass loadings were calculated using the constituent concentrations and multiplying these by the flow rates with appropriate conversion factors applied. These values are reflective of the total pollutant load reaching a facility. Flow, SS, BOD, and COD are evaluated. The results are shown for each plant in Table 4-4. Recent conditions are represented using data from 2007 through 2009. In addition, the same information from the 2010 Plan, representing fiscal year 1992–93, is presented for historical comparison. The mass loading data indicate that overall loads have (1) increased at the SJCWRP, (2) decreased at the WNWRP, LCWRP, and JWPCP, (3) remained relatively unchanged at the POWRP and LBWRP.

Table 4-4. Comparison of Recent (2007–2009) and Historical Wastewater Loads

Influent Constituent	Units	Years	JOS Treatment Plants						JOS Totals
			POWRP	SJCWRP	WNWRP	LCWRP	LBWRP	JWPCP	
SS	1,000 lbs/d	1992–1993	26	191	25	117	52	1,229	1,640
	1,000 lbs/d	2007–2009	27	225	15	80	43	1,222	1,611
Total BOD	1,000 lbs/d	1992–1993	24	169	22	85	37	985	1,323
	1,000 lbs/d	2007–2009	27	195	12	75	38	1,049	1,397
Total COD	1,000 lbs/d	1992–1993	51	353	46	199	94	2,173	2,917
	1,000 lbs/d	2007–2009	57	454	31	160	90	1,869	2,661

SS = suspended solids

BOD = biochemical (or biological) oxygen demand

COD = chemical oxygen demand

lbs/d = pounds per day

4.7.4 Constituent Concentrations Review

Influent data for SS, BOD, and COD, and effluent data for TDS for each of the WRPs were examined to see if any long-term trends were exhibited. These long-term trends may be representative of future concentrations.

The influent annual average SS, BOD, and COD concentrations for each of the WRPs over a 25-year timeframe are shown on Figures 4-1, 4-2, and 4-3, respectively. While variations over time are evident for each of the constituents, there are no apparent, substantive trends.

The effluent concentrations of TDS are shown on Figure 4-4. TDS concentration is an important characteristic of WRP effluent that can impact potential reuse applications. Although these data exhibit year-to-year variations, long-term trends of increasing TDS concentrations are not apparent.

Similar to the WRPs, influent data at the JWPCP was also analyzed. The historical influent SS, BOD, and COD for the JWPCP are presented on Figure 4-5. These data span 25 years and indicate increasing BOD concentrations, fluctuating SS concentrations, and decreasing COD concentrations. Increasing BOD concentrations are expected in the future due to increases in primary sludge and waste activated sludge solids that will be discharged to the JWPCP from the WRPs. The decreasing COD concentrations over the last three decades might be the result of the implementation of the Sanitation Districts' industrial pretreatment program beginning in the 1970s.

4.7.5 Characteristics Summary

An assessment of historic and recent wastewater characteristics within the JOS forms the basis for projecting future conditions. Overall, the loadings and concentrations are expected to remain relatively consistent with the population served. On this basis, future key parameters of BOD, SS, and COD are assumed to correspond to the values derived from 3-year averages.

4.7.6 Effluent Quality

Effluent quality requirements for surface water discharges, recycled water usage, and groundwater recharge are established by the Los Angeles Regional Water Quality Control Board (LARWQCB). Specific constituent limits are contained within permits issued to each of the treatment plants and summarized in Chapter 3. Each of the JOS treatment plants is reviewed in terms of actual effluent quality and permit compliance for these parameters within this section.

4.7.6.1 Pomona Water Reclamation Plant

The discharge requirements for the POWRP include approximately 7,800 numeric limits that must be met each year based on quantitative results of final effluent and receiving water sampling and analyses. During 2010, the POWRP successfully met all numeric limits and qualified for a National Association of Clean Water Agencies (NACWA) Gold Award.

4.7.6.2 San Jose Creek Water Reclamation Plant

The discharge requirements for the SJCWRP include approximately 27,500 numeric limits that must be met each year based on quantitative results of final effluent and receiving water sampling and analyses. During 2010, the SJCWRP successfully met all numeric limits and qualified for an NACWA Gold Award.

4.7.6.3 Whittier Narrows Water Reclamation Plant

The discharge requirements for the WNWRP include approximately 9,200 numeric limits that must be met each year based on quantitative results of final effluent and receiving water sampling and analyses.

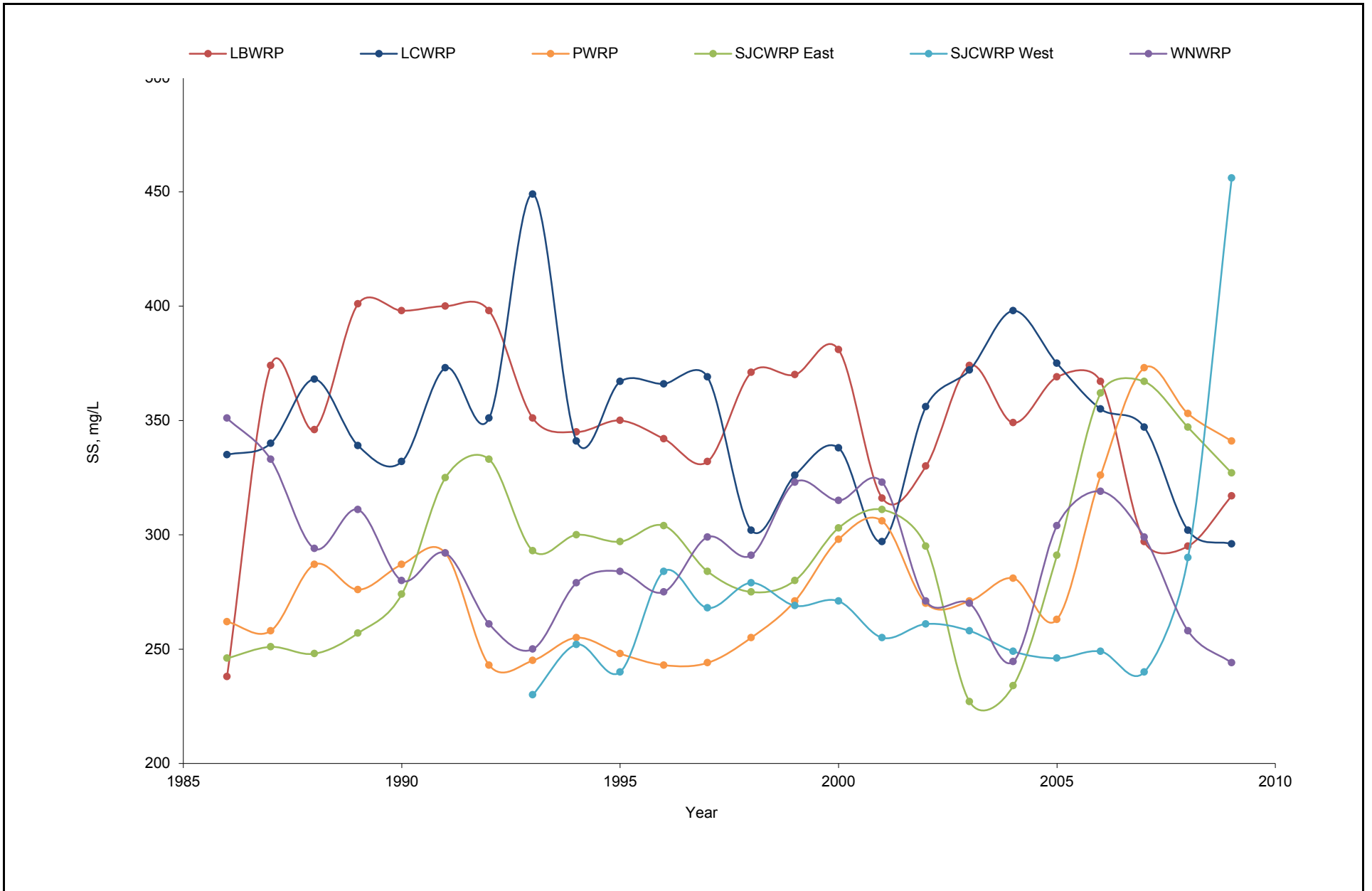

FIGURE 4-1



Historical WRP Influent Suspended Solids Concentrations

Source: Sanitation Districts of Los Angeles County 2011

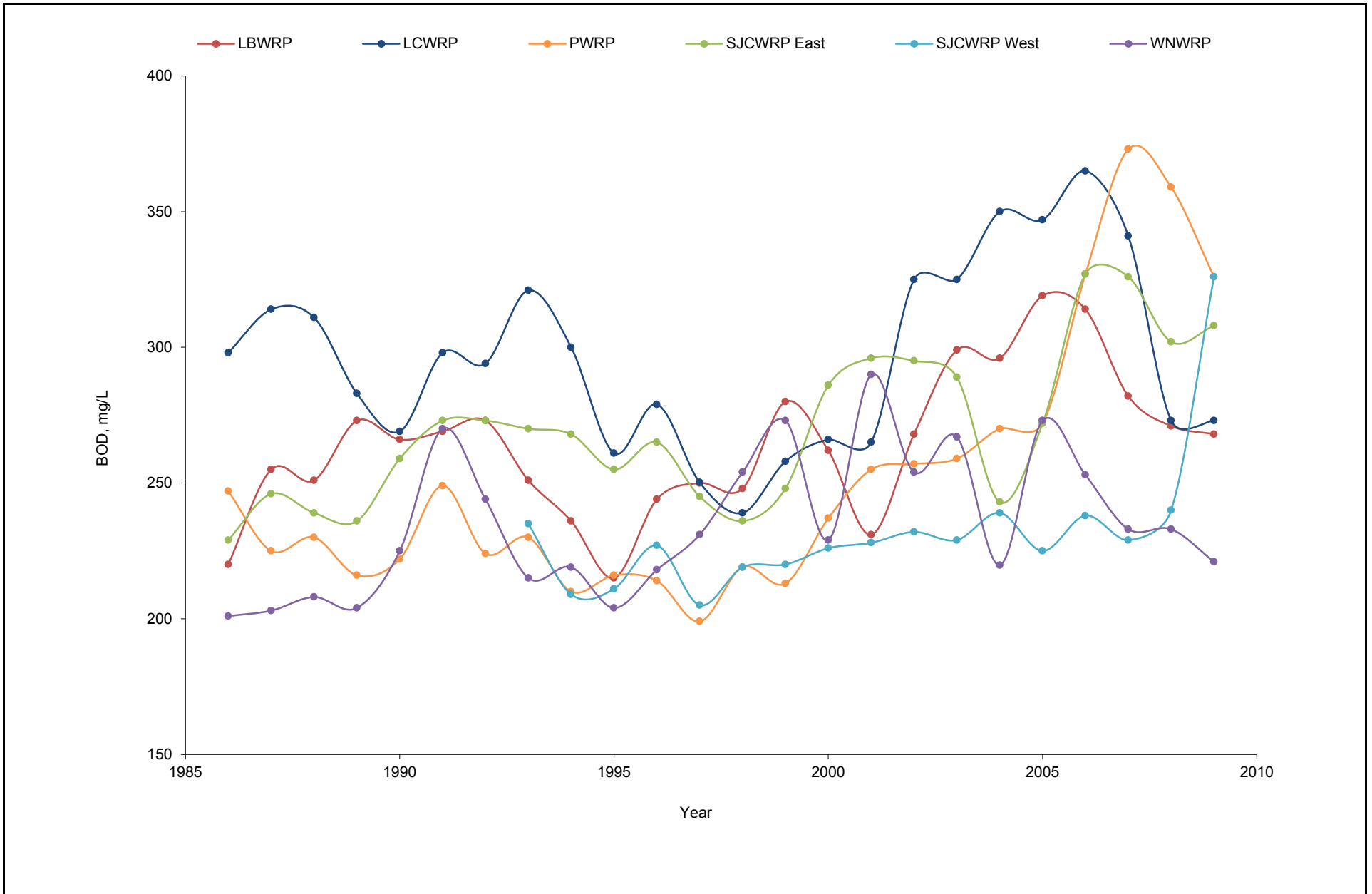

FIGURE 4-2

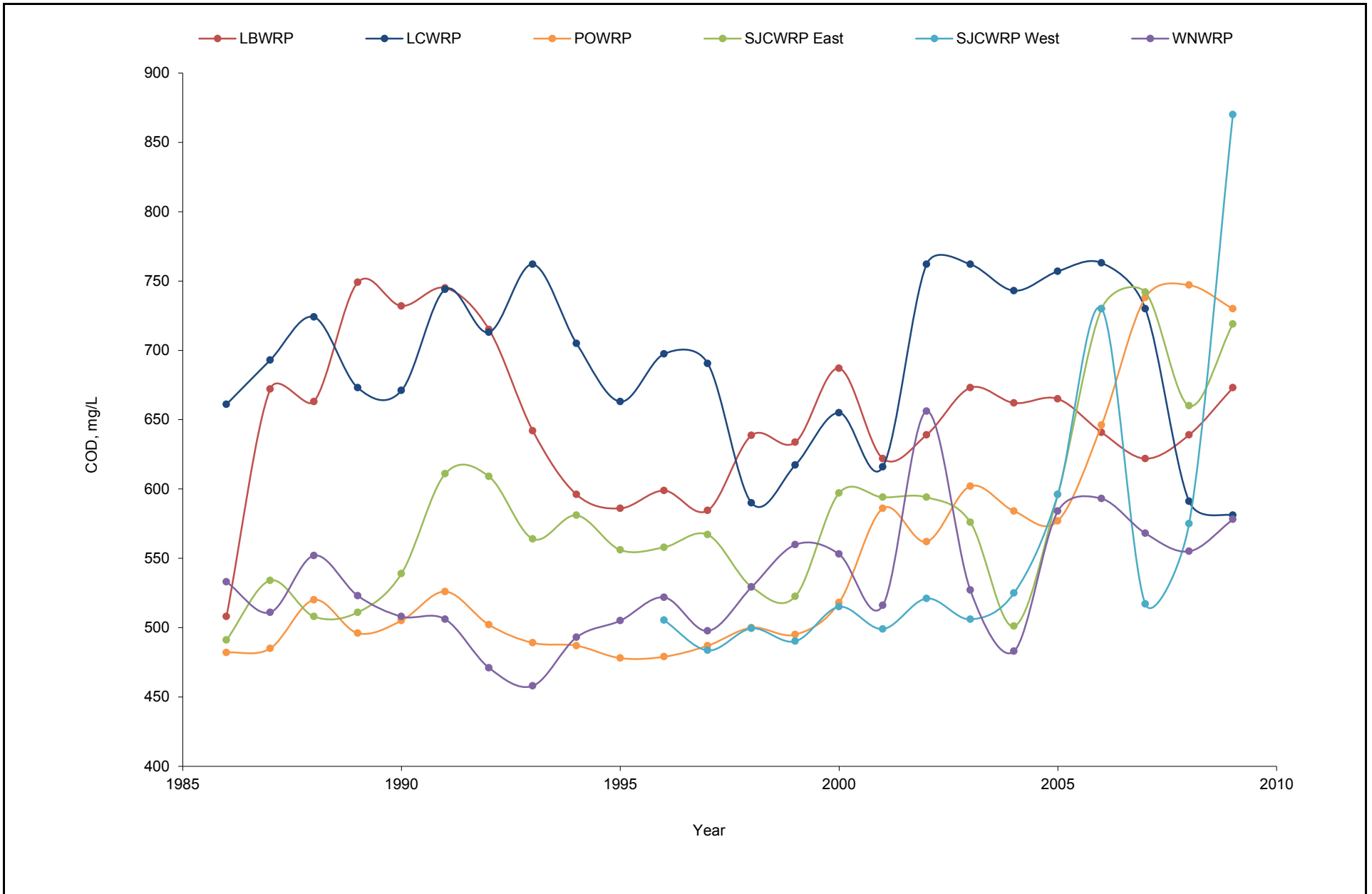

FIGURE 4-3



Historical WRP Influent COD Concentrations

Source: Sanitation Districts of Los Angeles County 2011

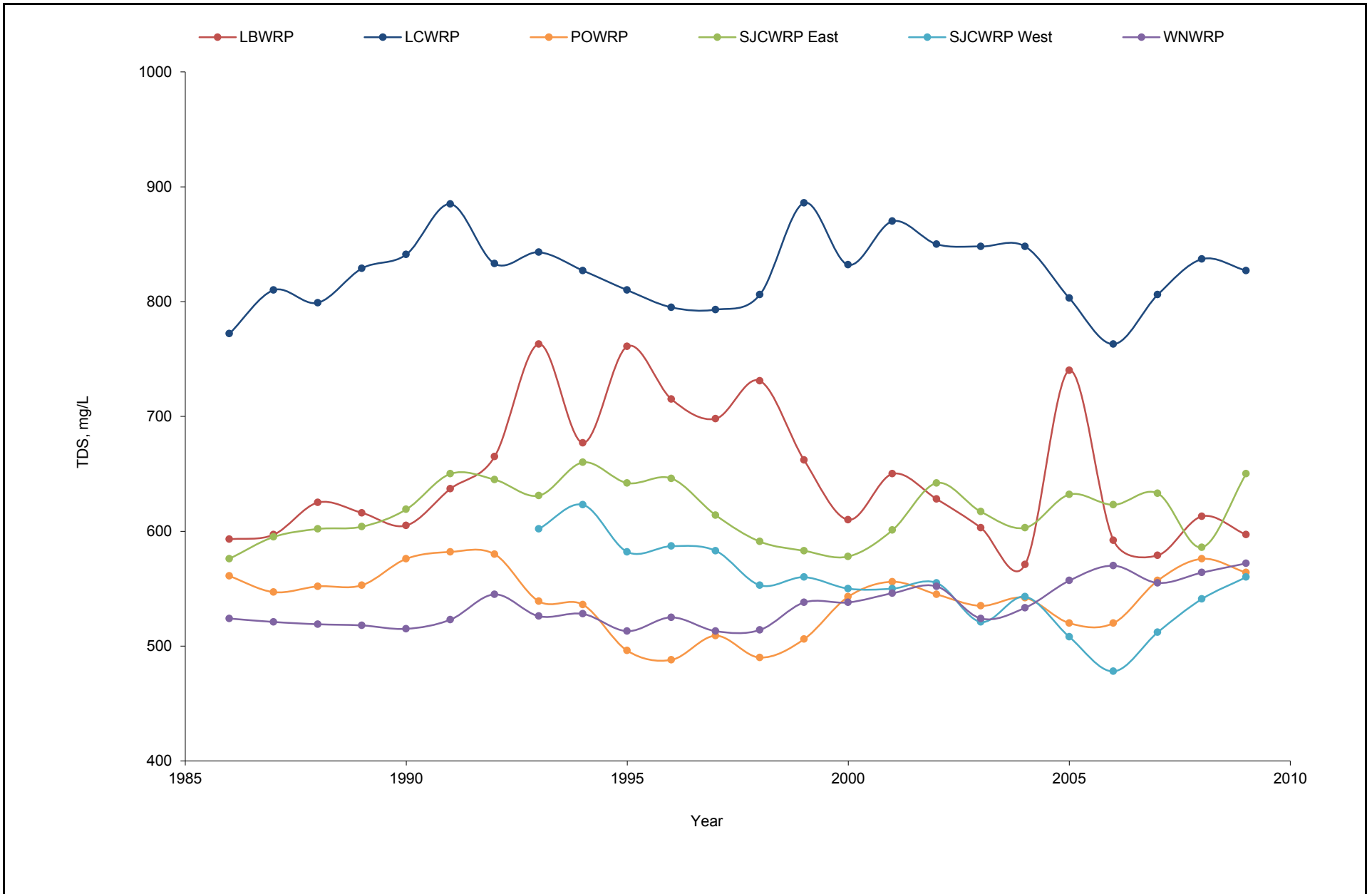

FIGURE 4-4



Historical WRP Effluent TDS Concentrations

Source: Sanitation Districts of Los Angeles County 2011

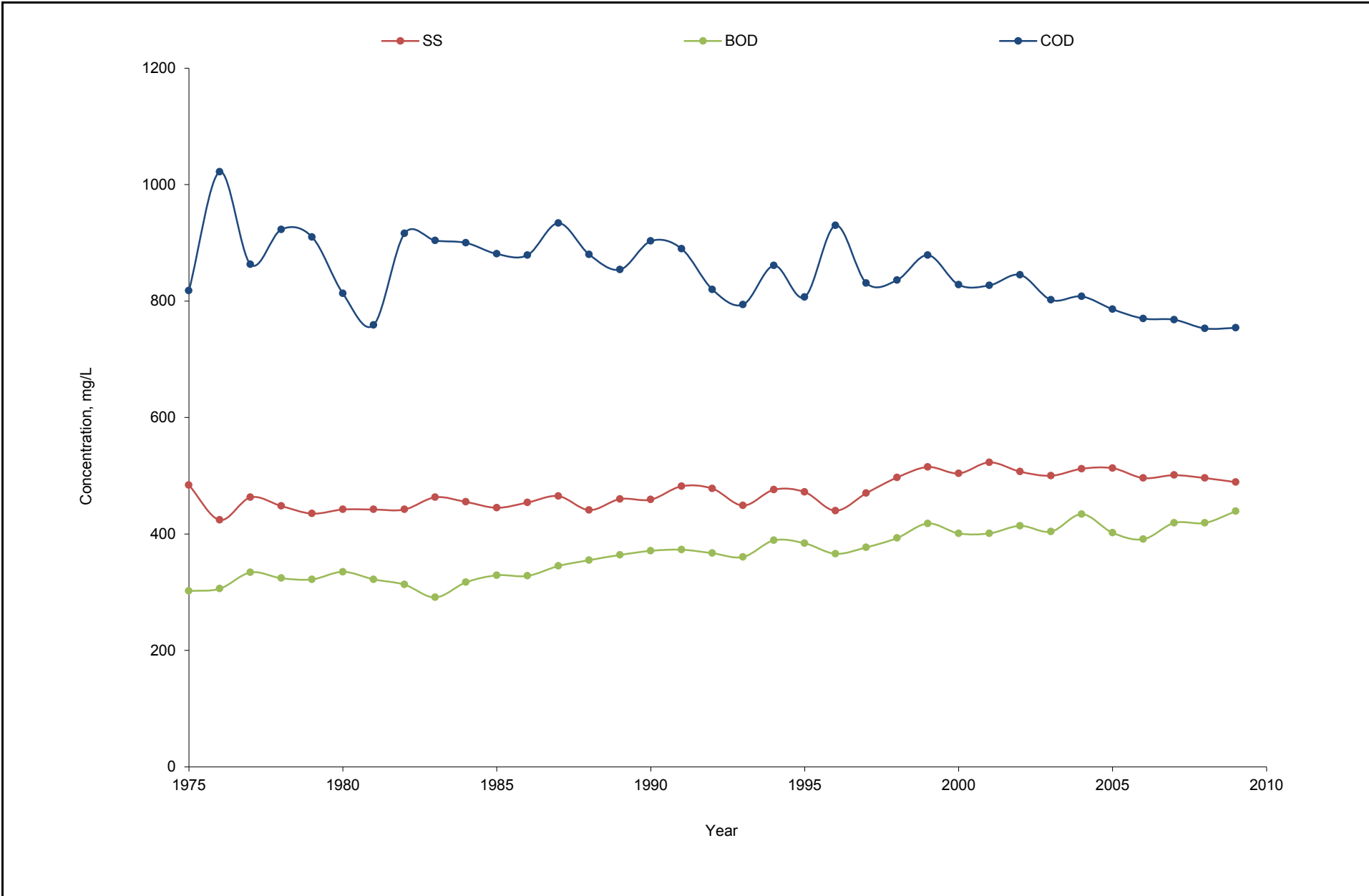

FIGURE 4-5

Historical JWPCP Influent Concentrations



Source: Sanitation Districts of Los Angeles County 2011

During 2010, the WNWRP successfully met all numeric limits and qualified for an NACWA Gold Award.

4.7.6.4 Los Coyotes Water Reclamation Plant

The discharge requirements for the LCWRP include approximately 7,800 numeric limitations that must be met each year based on quantitative results of final effluent and receiving water sampling and analyses. During 2010, the LCWRP had only one exceedance of the numeric limits and qualified for an NACWA Silver Award.

4.7.6.5 Long Beach Water Reclamation Plant

The discharge requirements for the LBWRP include approximately 5,700 numeric limits that must be met each year based on quantitative results of final effluent and receiving water sampling and analyses. During 2010, the LBWRP successfully met all numeric limits and qualified for an NACWA Platinum Award. The Platinum Award is given to facilities that have not had any NPDES effluent discharge violations in five years.

4.7.6.6 La Cañada Water Reclamation Plant

During 2010, the LACAWRP had only two exceedances of the non-NPDES permit containing waste discharge requirements and water reclamation requirements for irrigation. All effluent is stored and reused with no surface water discharge occurring.

4.7.6.7 Joint Water Pollution Control Plant

The discharge requirements for the JWPCP include approximately 27,000 numeric limits that must be met each year based on quantitative results of final effluent and receiving water sampling and analyses. During 2010, the JWPCP successfully met all numeric limits, qualifying for an NACWA Platinum Award. This plant has achieved 100 percent compliance with discharge limits since 2002.

4.8 Wastewater Flow Projections

Projections of average daily wastewater flow rates are used to determine the needed capacity of treatment and conveyance facilities. Over the 2050 planning horizon, the population in the JOS is projected to increase, which will in turn increase the amount of wastewater flows to be conveyed and treated. This section reviews the methodology used in projecting future flows and presents the results. Comparing the projected flows with existing capabilities serves as the foundation for assessing future facility needs.

4.8.1 Methodology

An estimation of the future wastewater flows and loading within the JOS is most dependent on two factors:

- **Per-capita Generation Rate:** The average amount of wastewater flow contributed to the system per person. It is based on current wastewater flows and the corresponding tributary population. Population data from the U.S. Census Bureau, the California State Department of Finance (DOF), and the Los Angeles County Assessor's Office were used to establish a per-capita generation rate.

- **Population Projections:** The amount of people served by the JOS. Future JOS population was projected using forecasts provided by the Southern California Association of Governments (SCAG).

Flow projections also take into account the discrete contribution from industrial and contract flows.

4.8.1.1 Per-Capita Generation Rate

A representative residential/commercial per-capita flow generation value was developed for the JOS using data from 2000–2007 by applying the following equation:

$$\text{Total Flow} = (\text{Residential/Commercial Flow Rate} \times \text{Population}) + \text{Industrial Waste Flow} + \text{Contract Flow}$$

First, the residential/commercial portion of the flow for each year was determined. The residential/commercial contribution was calculated by subtracting the industrial waste (IW) and contract flow from the total flow. An adjustment was then made to account for those residents using onsite systems, commonly referred to as septic tanks. The determination of the population served by septic tanks was refined from previous planning efforts. In the past, the population served by septic tanks was assumed to be a single percentage that was applied to the entire JOS. For this analysis, the specific parcels connected to septic tanks were identified, as was the population associated with these parcels based on Los Angeles County Assessor’s Office data. Next, the tributary population associated with residential/commercial flow was determined by subtracting the population served by septic tanks from the total population within the JOS. Finally, the residential/commercial flow was divided by the population to determine the per-capita generation rate.

Historic population data was derived from DOF information. Historic flow data were taken from the Sanitation Districts’ records. The results of the analysis for each year are presented in Table 4-5. The average value of 83 gallons per capita per day (gpcd) was selected as the per-capita generation rate for future flow projections. This value is consistent with those used by other wastewater agencies and is within the range of values (54–130 gpcd) for residential contributions.

Table 4-5. Per-Capita Flow Generation Results for JOS Tributary Area

Year	Tributary Population ^a	Total Flow (MGD)	Contract Flow (MGD)	IW Flow (MGD)	Residential/Commercial Flow (MGD)	Per Capita Generation Rate (gpcd)
2000	4,697,287	498	3.2	66.4	429	91
2001	4,765,762	486	3.7	64.0	419	88
2002	4,847,225	475	3.5	62.1	409	84
2003	4,919,916	473	3.9	61.0	408	83
2004	4,975,253	471	3.6	60.9	406	82
2005	5,013,939	480	3.2	60.0	417	83
2006	5,031,001	456	4.1	57.1	394	78
2007	5,053,455	430	4.1	57.7	369	73
Average	4,912,980	471	3.7	61.2	406	83

^a Population figures exclude residents of parcels connected to septic tanks.

Residential water conservation can affect the per-capita wastewater generation rate. To determine if continuing water conservation efforts within the JOS tributary area could influence the long-term per-capita flow generation rate, a review of water use and supply data was performed. Published data for 51 Southern California retail water agencies serving over 5.8 million people (2005) were examined for

trends in projected water demand through 2030. Trends were similar for single- and multi-family residential and for commercial land uses.

Approximately 47 percent of the water agencies did not publish sufficient data to calculate water demand per population served. Approximately 40 percent are expecting either declining (7 percent) or flat (33 percent) per-capita water demand through 2030. The remaining 13 percent are expecting an increase in demand through the same period. These results indicate that a constant per-capita flow generation rate is reasonable for future wastewater projections. The per-capita rate for future projections will, therefore, remain constant at 83 gpcd for the purposes of this plan.

4.8.1.2 Population Projections

Source Information

SCAG population projections, based on the 2000 Federal Census and contained in the 2008 Regional Transportation Plan (RTP), served as the basis for JOS population projections. However, the 2008 RTP only had projections through the year 2030. SCAG provided the 2050 projections at the Sanitation Districts' request.

Population Distribution

SCAG data is provided by census tract, and the Sanitation Districts use a parcel-based geographic information system (GIS) model to project wastewater flows. The SCAG population projections were distributed among parcels using parcel-based residential land use information obtained from the Los Angeles County Assessor's Roll. The county data provides five separate residential land use types corresponding to different residential densities. These land use types are presented in Table 4-6. The weighting factor relates different occupant densities for these residential uses to that of a single-family residence (SFR). Using the weighing factors, the census tract population was split proportionately among the parcels, providing a population for each parcel in the JOS.

Table 4-6. Residential Land Use Types and Corresponding SFR Equivalents

Land Use Type*	Weighting Factor (Equivalent SFR)
SFR – Single-Family Residential	1
DUP – Duplex	2
TRIP – Triplex	3
QUAD – Fourplex	4
MULT – Multi-family Residential	20 (five or more units; unspecified number of floors)

Population and Parcel Adjustments

A number of adjustments were used to refine the values associated with tributary population projections and parcel-based population figures. Parcels on septic tanks do not contribute wastewater flow into the JOS. These parcels were identified and eliminated from consideration for calculations involving tributary populations. The separate identification of these parcels also permitted a phased approach in determining the impact of future septic tank connections to the JOS. It was assumed that all current septic tank systems would be connected to the JOS by 2050. For the 2050 projections, the Sanitation Districts' entire sphere of influence (SOI) was assumed to represent the service area. This results in a slight increase to the current service area.

Tributary Area Boundaries

Ten separate tributary areas for the treatment plants were identified and are depicted on Figure 4-6. The tributary areas are based on the settings within the conveyance system. Flow splits and diversions in the

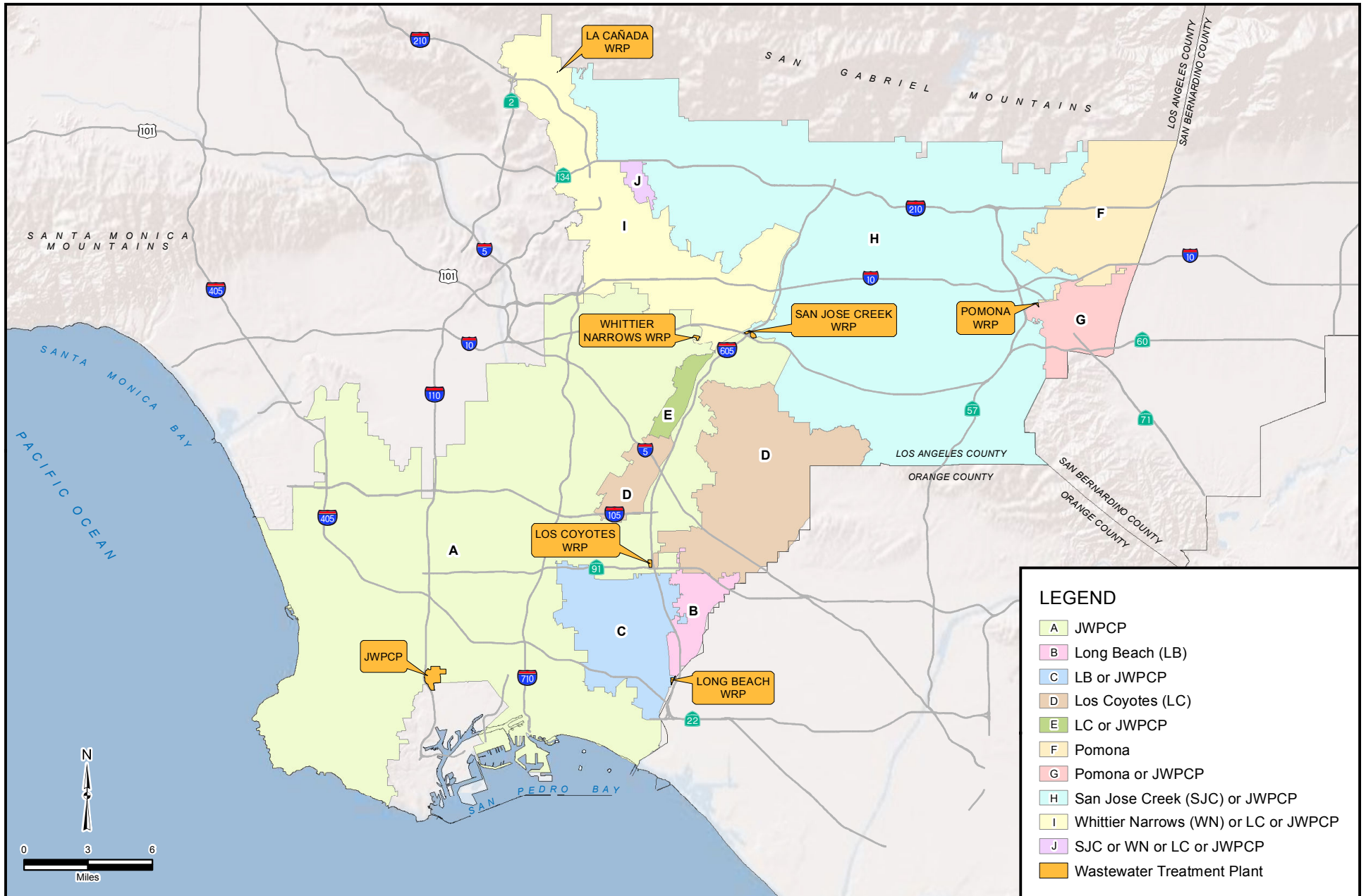

FIGURE 4-6

conveyance system can be modified, which would shift the tributary populations. However, for planning purposes, it is assumed that modifications to the flow splits and diversions would be minimal and that the tributary areas depicted on Figure 4-6 are representative of future flows.

2050 Population Projections

Population projections were produced for the entire JOS and delineated in terms of designated tributary areas. The 2000 Census population figures and projections for 2050 are presented in Table 4-7. The total tributary residential population includes the service area's entire population, including those served by septic systems. The contributing residential population reflects only those residents connected to the JOS conveyance system and does not include the population served by septic systems. For the purposes of these projections, it is assumed that all septic systems would be completely phased out by the year 2050 so that the total tributary population and contributing population are the same value. In 2050, the projected JOS tributary population will increase to approximately 6.3 million people. Historic JOS populations and the projected 2050 JOS population are shown on Figure 4-7.

Table 4-7. Residential Population Projections

JOS Tributary Areas (by WRP)	Residential Population		
	Total Tributary 2000	Contributing 2000	Tributary/Contributing 2050 ^a
JWPCP	2,530,097	2,521,663	3,131,658
LBWRP	68,514	68,487	76,974
LBWRP or JWPCP	181,700	181,496	216,668
LCWRP	320,379	320,013	400,221
LCWRP or JWPCP	38,032	37,934	46,223
POWRP	93,156	92,887	132,445
POWRP or JWPCP	95,265	95,071	147,571
SJCWRP or JWPCP	1,068,375	1,054,474	1,548,632
SJCWRP or WNWRP or LCWRP or JWPCP	10,683	10,673	13,641
WNWRP or LCWRP or JWPCP	422,885	415,311	543,581
Total for JOS	4,829,086	4,798,009	6,257,614

^a In 2050, total tributary is equal to contributing because it is anticipated that all septic systems will have been phased out.

4.8.2 Projected Wastewater Flows

Future flows were projected in terms of three major source components: residential, industrial, and contract. The future residential flow contributions were calculated using the previously developed per-capita generation rate, and applying it to the projected JOS tributary populations. The industrial and contract flow components were separately projected based upon long-term trends. Projected wastewater flows for the JOS are presented in Table 4-8 for each major component source. The projected tributary flows for each of the treatment plants are shown in Table 4-9. The projected flow of 612 MGD exceeds the currently permitted capacity of the JOS. Alternatives for managing the flow in excess of the currently permitted capacity are evaluated in Chapter 6.

Table 4-8. 2050 Wastewater Flow Projections by Component Source for the JOS

Source	MGD
Residential Flows	520
IW Flows	82
Contract Flows	10
Total Average Wastewater Flow	612

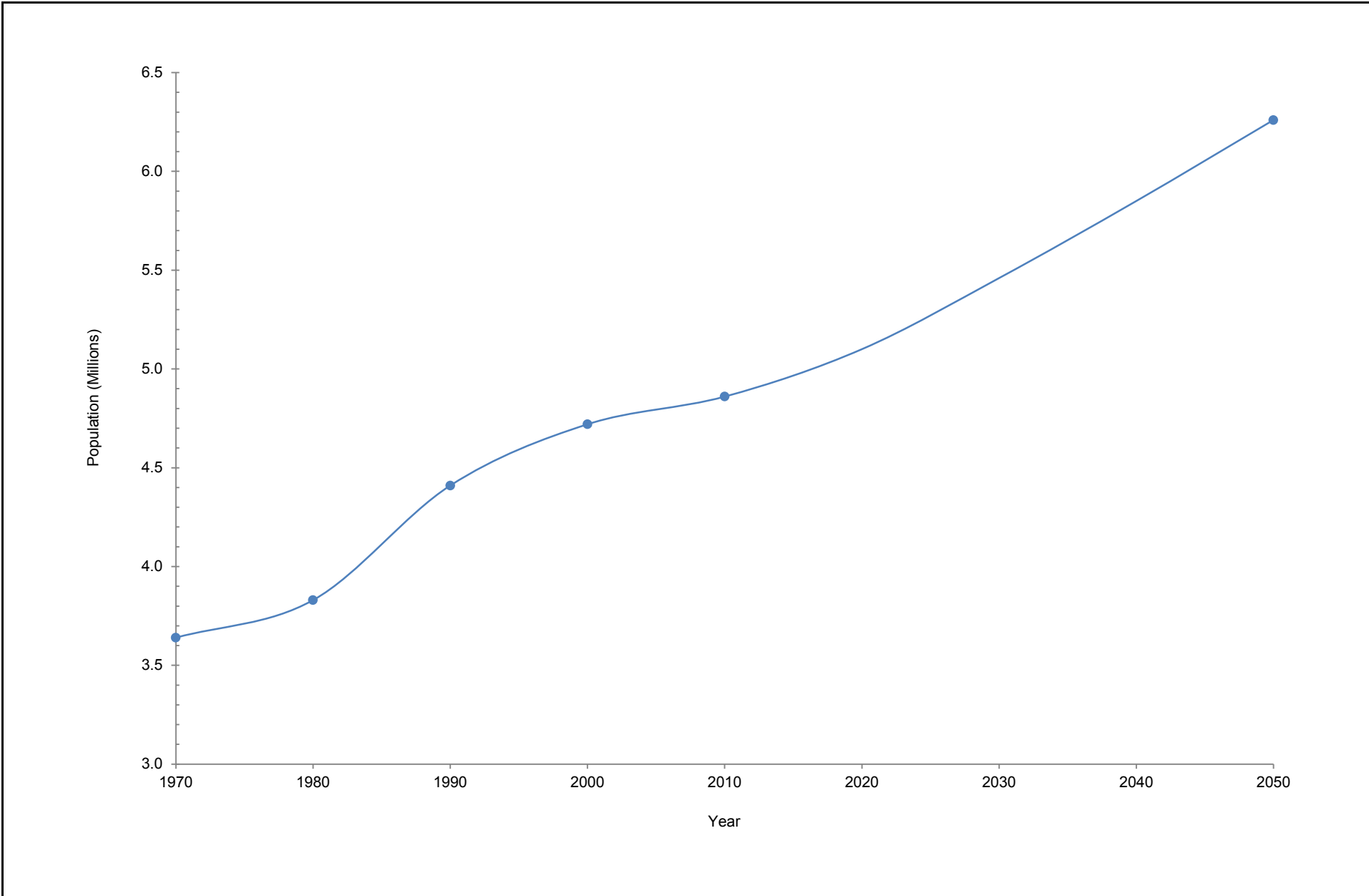

FIGURE 4-7



Historic and Projected Populations in the Joint Outfall System

Source: CA Department of Finance 2011

Table 4-9. 2050 Projected Tributary Flows for the JOS Treatment Plants

Treatment Plant	2050 Projected Tributary Flow ^a
POWRP	13
SJCWRP	135
WNWRP	44
LCWRP	38
LBWRP	23
JWPCP ^b	359
Total Average Wastewater Flow	612

^a Based on a per capita generation rate of 83 gpcd and current conveyance system configuration and settings. Flows in excess of a WRP's capacity would be bypassed and treated at another WRP or the JWPCP.

^b Tributary flow for the JWPCP does not include flows that bypass the WRPs.

4.8.3 Wastewater Flow Variations and Peaking

Wastewater does not flow into the treatment plants at a constant rate. The flow rate varies from hour to hour reflecting changes in the residential, commercial, and industrial activity taking place within the area served. The constituent loadings can vary as well depending on a number of different factors. The degree of flow variation can also be affected by the service area's configuration. Larger, more linear service areas possess the potential for greater attenuation of the flow rate variations.

In assessing the capabilities of existing systems and determining future facility needs, it is critical to incorporate the impacts of flow variations into the analysis. Though low flow periods may have some facility or operational impacts, the greatest concerns relative to conveyance and treatment capacity are the peak flows. For the JOS, three separate types of peak flows, and associated peaking factors, are evaluated: daily (diurnal), cyclical, and wet weather (seasonal).

Each of these is described in the subsections that follow, including a discussion of their impact on the planning process. With respect to peaking, the WRPs and the JWPCP are sufficiently different and, therefore, are discussed separately.

4.8.3.1 Daily (Diurnal) Flow Variations

The WRPs experience diurnal flow variations similar to other municipal treatment plants. The initial peak generally takes place in the morning hours, around 10:00 a.m. Flows are sustained for a period, followed by a slight reduction around 3:00 p.m. (15:00) and a significant reduction, starting around midnight. The lowest flows generally occur around 5:00 a.m., and the cycle starts over again. Weekends follow a similar pattern, but there is a second peak in the early evening hours, around 7:00 p.m. (19:00). The typical flow pattern found at the WRPs for dry weather flows is depicted on Figure 4-8.

The dry weather peaks are termed *peak sanitary flows*. For planning purposes, the peak sanitary flows were calculated using the following formula:

$$\text{Peak Sanitary Flows} = \text{Average Annual Peak Daily Flow} + 1 \text{ Standard Deviation}$$

The results for each WRP are presented in Table 4-10 and reflect the period of July 2006 through July 2007. In this analysis, the SJCWRP was divided between the east and west plants since they are hydraulically separated. Because the average value plus one standard deviation represent the 67th percentile value, the resulting estimated peak daily sanitary flow is not overly conservative.

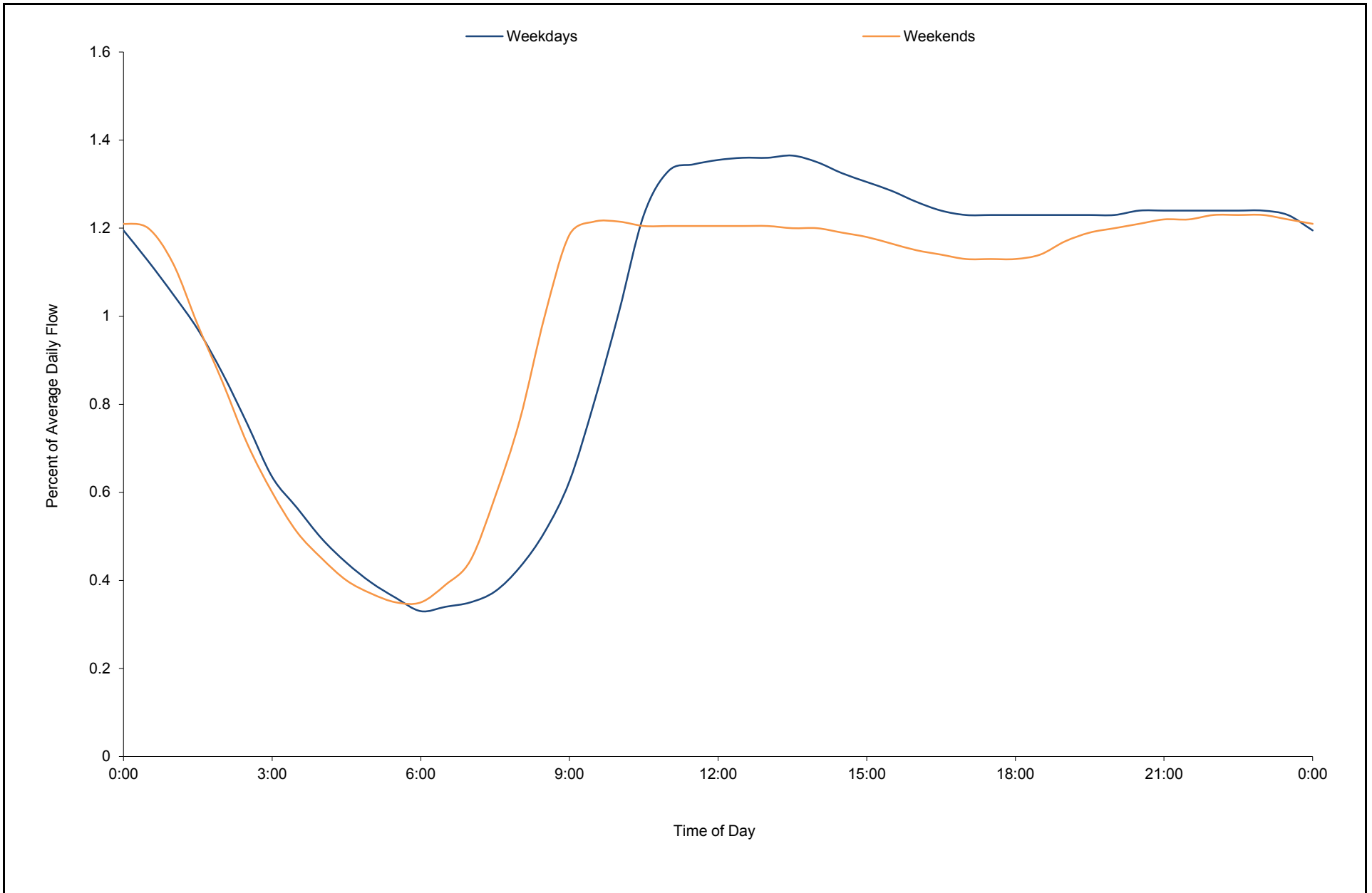

FIGURE 4-8

Table 4-10. Water Reclamation Plant Sanitary Flow Peaking Factors

WRP	Sanitary Peaking Factor ^a
POWRP	1.81
SJCWRP East	1.48
SJCWRP West	1.77
WNWRP	1.28
LCWRP	1.48
LBWRP	1.77

^a The sanitary peaking factor is based on the amount of flow treated by the WRPs; most of the WRPs bypass some of the tributary peak flow.

Due to the size and configuration of the conveyance system, the JWPCP routinely experiences a sanitary flow peaking factor lower than the WRPs. A typical day's dry weather flow variations at the JWPCP are depicted on Figure 4-9. The diurnal sanitary flow peaking factor for the JWPCP is approximately 1.24.

4.8.3.2 Cyclical Loading Variations

The WRPs do not see a significant variation in flows associated with any particular cycle. However, the WRPs experience higher organic loadings on the weekends. In particular, the ammonia loading is routinely higher on the weekends. The JWPCP does not experience any significant cyclical loading variations.

4.8.3.3 Wet Weather Peaking

Wet weather peak flows are sometimes referred to as seasonal peaks, indicating the predominance of occurrence when the heaviest rain occurs. The increase in system flows associated with wet weather events results from a combination of infiltration and inflow (I/I) into the conveyance system.

Infiltration is groundwater that enters sewer pipes (interceptors, collectors, manholes, or house laterals) through holes, breaks, joint failures, connection failures, and other openings. Infiltration quantities often exhibit seasonal variation in response to groundwater levels. Storm events can trigger a rise in groundwater levels and increase infiltration flows. The highest infiltration flows are observed following significant storm events or following prolonged periods of precipitation.

Inflow is surface water that enters the wastewater system from yard, roof, and footing drains; cross-connections with storm drains; downspouts; and through holes in manhole covers. Inflow occurs as a result of storm events (including rainfall and, in some areas, snowfall, springs, or snowmelt) that contribute to excessive conveyance system flows. Peak inflow can occur during heavy storm events when the stormdrain systems are surcharged, resulting in hydraulic backups and subsequent surface ponding.

Conveyance and treatment systems are primarily designed to manage wastewater flows without the addition of significant volumes from other sources. I/I adds a substantial hydraulic component to the loading of both systems. The inability of the conveyance system and treatment plants to accommodate these higher flows could potentially result in conveyance system overflows or the discharge from treatment plants of less than completely treated effluents.

The State Revolving Fund (SRF) guidelines require an evaluation of the non-existence or possible existence of excessive I/I in the existing sewer system. If the average daily flow during periods of sustained high groundwater is less than 120 gpcd, a Sewer System Evaluation Survey (SSES) is not required. If it is above 120 gpcd, the applicant must perform a SSES to determine whether it is cost-

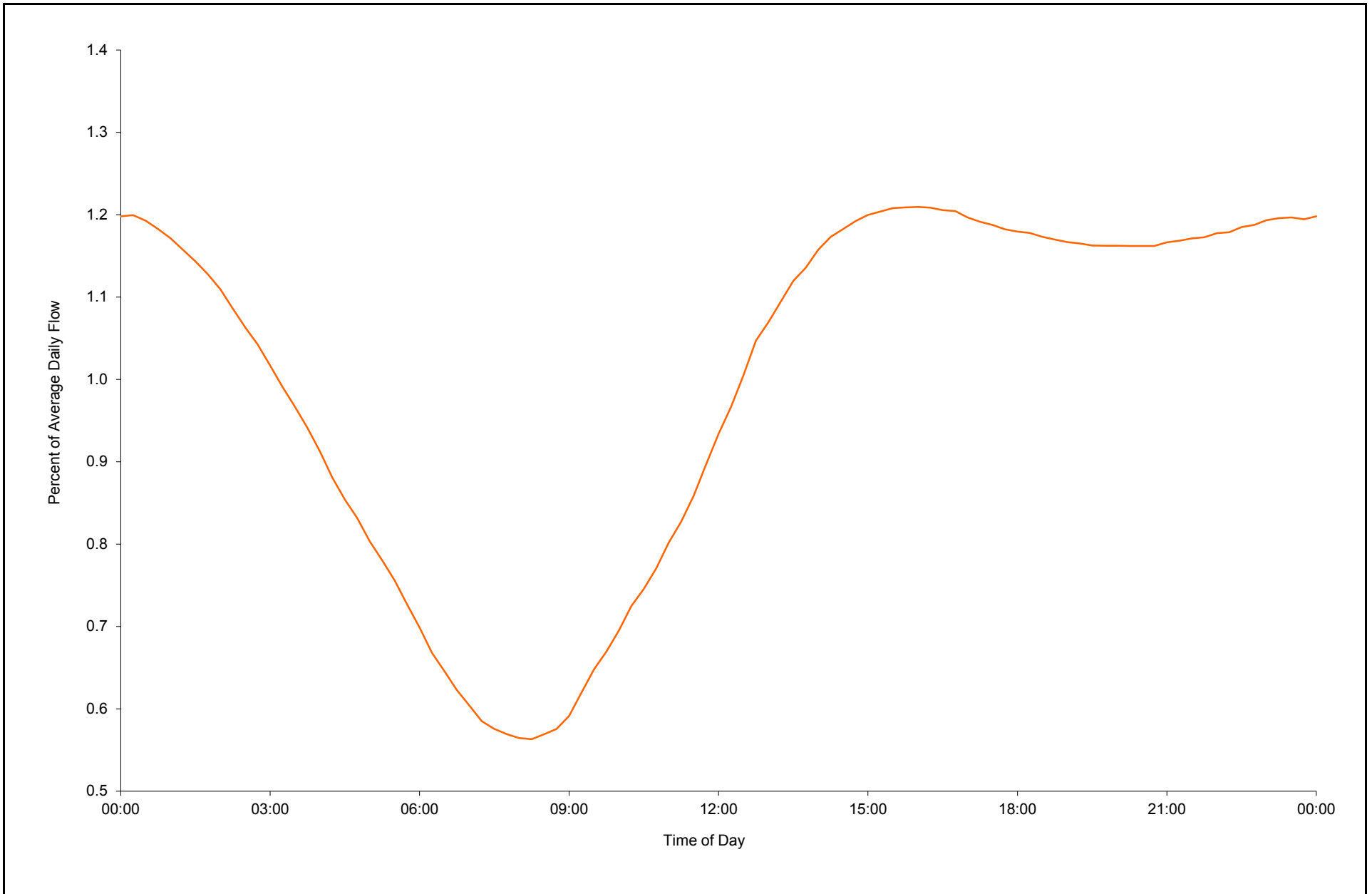

FIGURE 4-9

effective to treat or correct the I/I. If the peak flow during a storm event (highest 3-hour average) exceeds 275 gpcd, a SSES must be completed.

According to the National Weather Service, the 2004–2005 rainfall season was the second wettest season in Los Angeles since recordkeeping began in 1877 (the wettest season being the 1883–1884 season). Therefore, plant flow data from 2004–2005 were used to evaluate I/I in the existing JOS sewer system.

The average residential/commercial flow rate in the JOS during the rainfall season (October 2004 through March 2005) was 435.3 MGD. This value does not include industrial waste or contract flows. The maximum overall flow rate in the JOS that season occurred during a storm lasting from January 7 through January 10, 2005. The maximum residential/commercial storm flow rate during this storm equaled 994.1 MGD. Dividing these flows by the JOS sewered population of 4,994,596 (average of 2004 and 2005 populations as shown in Table 4-5) results in a per capita generation rate of 87 gpcd during the rainfall season (infiltration) and 186 gpcd during the peak storm event (inflow). These rates fall well below the SRF threshold values of 120 gpcd for infiltration and 275 gpcd for inflow, respectively.

4.8.3.4 Water Reclamation Plant Wet Weather Peaking Factors

The potential wet weather peaking factors (peak storm) for the WRPs were assessed in terms of past events. For the POWRP, WNWRP, LCWRP, and LBWRP, the recent, highest wet weather plant flows took place in connection with a storm event on February 1, 1998. For the SJCWRP, the recent, highest wet weather plant flows took place in connection with a storm event on February 5, 2005. As with the diurnal peaking factors review, the SJCWRP was examined in terms of the east and west plants. Peaking factors for the WRPs are presented in Table 4-11.

Table 4-11. Water Reclamation Plant Wet Weather Flow Peaking Factors

WRP	Wet Weather Peaking Factor ^a
POWRP	2.6
SJCWRP East	3.1
SJCWRP West	2.1
WNWRP	2.6
LCWRP	3.0
LBWRP	2.8

^a The wet weather peaking factor is based on the amount of flow treated by the WRPs; most of the WRPs bypass some of the tributary peak flow.

4.8.3.5 Joint Water Pollution Control Plant Peak Wet Weather Flows

Determining peak wet weather flow at the JWPCP is important because it dictates the size of the JWPCP effluent management system. The JWPCP has a more comprehensive set of influent flow data available than the WRPs; therefore, a more sophisticated approach than using historic peaking factors was possible to assess I/I contributions at the JWPCP.

With sufficient wet weather flow data and corresponding rainfall data, relationships can be derived between rainfall intensity and rainfall dependent infiltration and inflow (RDI/I). The approach applied at the JWPCP for this plan was the Inflow Coefficient Method (ICM). The ICM estimates peak RDI/I and total wet weather flow for any rainfall intensity.

The ICM establishes a statistical relationship between rainfall event severity (such as rainfall depth, duration, or intensity) and RDI/I in sanitary sewers based on the review of gauged historical rainfall and

sewer flow events. In order to evaluate the peak flow, a modification of the rational formula for storm flow can be used as follows:

$$Q = K_p i A$$

Where: Q = inflow rate, cubic feet per second (cfs)
 K_p = inflow coefficient for peak flow
 i = average rainfall rate for the time of concentration to the metering point, inches per hour (in/hr)
 A = sewered area, acres

For wet weather flows at the JWPCP:

Q = RDI/I
 K_p = a constant developed from historical data relating RDI/I and i from historical events
 i = intensity of a rainfall event (e.g., a 10-year or 25-year storm)
 A = area over which the storm occurs

For application of the ICM, the peak RDI/I rate is assumed to be independent of the sanitary wastewater flow component. The peak flow at the JWPCP in 2050 becomes the sum of the projected dry weather flows, the infiltration extracted from the high-groundwater dry day, and the peak RDI/I. The 2050 projected average dry weather flow within the JOS tributary area was discussed in Section 4.8.2. Although the projected 2050 flow exceeds the current treatment capacity of the JOS, expansion at the JWPCP is not recommended as part of this facilities planning effort. With no expansion at the JWPCP, it can be assumed that the maximum average daily flow at the JWPCP would be 400 MGD.

However, peak RDI/I is partially a function of rainfall intensity and duration. Therefore, it is reasonable to state the expected RDI/I in terms of return period rainfall statistics for the local area. The RDI/I increases with more severe (higher return period) rainfall. The results of the ICM analysis for recent (2007) conditions and year 2050 are summarized in Table 4-12.

With respect to the values presented in Table 4-12, the projected 927 MGD peak wet weather flow represents a worst-case scenario. In the development of tributary average dry weather flows (ADWFs), it was assumed that the upstream WRPs are not expanded and that all system flows beyond the WRPs' current capacities are treated by the JWPCP. It was also assumed that the peak wet weather flows take place at the same time as the peak diurnal flow. It was also assumed that the peak wet weather event in question takes place shortly after another major storm event that has raised groundwater elevations within the system to a level that maximizes the quantity of groundwater infiltration entering the conveyance system. This level of conservatism is warranted for planning level assessments of critical effluent management facilities.

Table 4-12. Summary of Predicted Flows at the JWPCP

Year	Rainfall Event Return Period ^a (years)	ADWF ^b	Dry Peaking Factor ^c	PDWF	GWI	Daily Peak Flow	RDI/I ^d	Increased RDI/I from SOI ^e	PWWF	Wet Weather Peaking Factor
2007	25	308	1.24	382	30	412	368	-	780	2.5
2050	25	400	1.24	496	30	526	368	33	927	2.3

^a Return period designations are based on climate norms for Coastal Southern California from NOAA Atlas 2: Precipitation Frequency Atlas of the Western United States, Volume III, by J.F. Miller, R.H. Frederick, and R.J. Tracey 1973. A 25-year return period is sufficiently conservative for an area the size of the JOS, because it assumes that the entire JOS would simultaneously experience a 25-year storm event.

^b Average dry weather flow for 2007 is calculated from JWPCP flow data for 2005. Average dry weather flows are based on 83 gpcd and population projections contributing to JWPCP, plus bypass flows from upstream WRPs and include industrial waste and contract flows.

^c Dry weather flow peaking factor is derived from one week of dry weather flow data in September 2005.

^d RDI/I is derived from the ICM results, and is assumed to remain constant over time.

^e RDI/I is assumed to increase with expanded service area only, and not with aging or deterioration of the collection system. All flows are MGD.

ADWF = average dry weather flow

PDWF = peak dry weather flow

GWI = groundwater infiltration

RDI/I = rainfall dependent infiltration and inflow

SOI = sphere of influence

PWWF = peak wet weather flow

PDWF = ADWF x PF

Daily Peak Flow = PDWF + GWI

PWWF = Daily Peak Flow + RDI/I

Wet Weather Peaking Factor = PWWF/ADWF

4.9 Wastewater Solids Projections

One of the primary byproducts of wastewater treatment and purification is residual solids. These solids or sludges are further processed prior to their ultimate disposal. The processes employed convert the residual sludges to biosolids, a product that can be put to a variety of beneficial uses. To assess the capabilities of the existing solids processing systems, and to determine future needs, the types and quantities of wastewater solids must be quantified. This section presents:

- Definition of solids sources and types
- Recent (2005 through 2009) solids production rates
- Basis for projecting future solids quantities
- Projections of future solids to be managed

Chapter 5 contains information on current solids processing systems and capabilities. This chapter presents an overview of potential future needs to be factored into subsequent alternatives assessments.

4.9.1 Solids Types and Sources

Within the JOS, the residual solids for each of the WRPs are returned to the sewers and conveyed to the JWPCP. Residual solids from the WRPs consist of primary solids, skimmings/scum, and waste activated sludge (WAS). The liquid treatment processes at the JWPCP remove most of the influent and process-generated solids at the JWPCP prior to effluent disposal. The following are the major sources of solids.

- **Primary Solids:** The source of primary solids is raw primary sludge (RPS), which is defined as the residuals removed from the primary sedimentation tanks.
- **Secondary Solids:** The source of secondary solids is WAS, which is generated by the activated sludge process and separated in the final sedimentation tanks.

While skimmings and scum removed at different stages of wastewater processing are also part of the solids processing systems, the quantities of these materials, relative to RPS and WAS, are very small. Other residual solids, such as grit or screenings, are removed at the headworks of the JWPCP.

4.9.2 Recent Solids Production

JWPCP monthly reports served as the primary source of information on solids at the facility. A 5-year timeframe (2005 through 2009) was evaluated to obtain a representative perspective on solids processing and solids generation rates. This data set provided recent information over a sufficient duration such that the results reflect the full spectrum of influent and operational scenarios impacting solids production.

A summary of the JOS solids generation data for 2005 through 2009, as well as the population served over that timeframe, is provided in Table 4-13. Solids production is expressed in dry tons per day (dtpd).

Table 4-13. Population and Solids Production Summary

Parameter	Year					5-Year Averages
	2005	2006	2007	2008	2009	
JOS Population	5,013,039	5,031,001	5,053,455	5,112,711	5,118,941	5,065,829
Raw Primary Sludge (dtpd)	497	480	478	462	450	474
Thickened WAS (dtpd)	280	276	257	256	234	261

dtpd = dry tons per day
WAS = waste activated sludge

Using the 5-year averages cited in Table 4-13, a per capita generation rate was calculated for each sludge type:

- RPS: 0.19 pounds per capita per day (ppcd)
- Thickened Waste Activated Sludge (TWAS): 0.10 ppcd

It was also assumed that these recent values are representative of future solids generation rates for the JOS, and were, therefore, used in the subsequent solids projections presented in Section 4.9.4.

4.9.3 Basis for Solids Projections

A variety of parameters influence the type and quantity of solids generated within treatment processes. There are a number of factors that can impact the accuracy of future quantity projections. Some of the limitations associated with the development of accurate and precise future quantity estimates include:

- Projecting quantities over an extended planning horizon. This project requires projections over a 40-year period.
- Predicting population growth over an extended planning horizon, because solids generation is dependent upon the size of the population served.

- Quantifying operational parameters (e.g., flow, SS, per capita contributions) for future conditions. Future values (concentrations, contributions, yields, etc.) may vary in either direction.
- Anticipating future operations affecting the transfer of solids from the upstream WRPs to the JWPCP. The JOS solids are the result of solids directly tributary to the JWPCP and the solids discharged into the JOS conveyance system by the upstream WRPs. The future division of flows between these sources may vary and may impact solids production and properties.
- Determining the processes to be employed and the manner by which these processes would be operated. Solids generation, process removal rates, and solids yield for soluble conversion are dependent upon the processes selected.

A simplified, empirical approach to projecting future solids generation at the JWPCP has been used. The steps include:

- Reviewing existing solids generation information for the JWPCP and selecting a representative data window to use. A 5-year timeframe of 2005 through 2009 was determined to be representative. Data were extracted from monthly summary operating reports for the selected time period.
- Determining the appropriate solids/sludge data sources to be used in the development of per capita contributions for primary and secondary solids. In this situation, the RPS and TWAS data sources provided the most appropriate basis for developing per capita contributions.
- Determining the JOS population served for the timeframe of 2005 through 2009 associated with solids generation data.
- Calculating a per capita contribution for RPS and TWAS, in ppcd.
- Applying the per capita contributions to the population projections.

This approach provides a rational basis for projecting future quantities of the two major solids types (primary and secondary) at the JWPCP.

4.9.4 Solids Projections

Using the calculated per capita solids generation rates, coupled with the projected 2050 JOS population, the following solids projections have been developed for the year 2050:

- RPS: 585 dtpd of solids at 3.32 percent and a flow of 4.23 MGD
- TWAS: 322 dtpd of solids at 5.52 percent and a flow of 1.40 MGD

These quantities were used in assessing the current systems' capacities, and in determining future facilities requirements. During the planning period, the JOS biosolids generation rate is projected to increase nearly 30 percent, from 1,470 wet tons per day (wtpd) (2005–2009) to 1,850 wtpd (2050).

4.10 Water Recycling and Reuse

4.10.1 Sanitation Districts' History of Water Recycling

The Sanitation Districts have actively promoted water recycling for nearly half a century. The Sanitation Districts' first report on water recycling was prepared in 1949, and described in detail the basic considerations of water recycling, including the opportunities that existed at that time. The report

concluded that the configuration of the Sanitation Districts' trunk sewer system and the available knowledge of wastewater treatment processes would permit the safe and economic recycling of wastewaters for specific uses to alleviate an impending water shortage and supplement the natural and imported water supplies of the area.

A second report, prepared in 1958, reaffirmed the general findings of the first report and made a specific proposal: demonstrate to the general public the feasibility of full-scale water recycling through the construction and operation of a 10 MGD water reclamation plant at Whittier Narrows. Subsequently, A Plan for Water Reuse was prepared in 1963 to determine where, when, and how additional water recycling facilities could and should be constructed.

Between 1966 and 1974, four water reclamation plants (POWRP, LCWRP, SJCWRP, and LBWRP) were constructed, thereby increasing the water recycling capacity in the JOS from 10 MGD to 87.5 MGD. These four water reclamation plants were expanded between 1975 and the present to provide an additional 105.2 MGD of water recycling capacity to the JOS. These expansions bring the total permitted recycling capacity of the JOS to 192.7 MGD.

During the 2009–10 fiscal year, the average recycled water production within the JOS service area was 124.2 MGD (139,000 acre-feet per year [AFY]), and the average reuse was 54.2 percent (67.4 MGD or 75,000 AFY).

For the 2009–10 fiscal year, the Sanitation Districts had 24 contracts for the sale and/or delivery of recycled water from its facilities. Because the Sanitation Districts cannot sell recycled water directly to a user served by a private water company, recycled water was provided to 29 water wholesalers and purveyors. These 29 wholesalers and purveyors made the recycled water available to 640 individual sites in 30 cities for different applications such as irrigation, industrial use, agricultural use, and groundwater recharge.

4.10.2 Previous Studies

Over the past 30 years, a number of documents were created to evaluate the potential water reuse market in the Southern California region. Among the most significant are:

- 1982 Orange and Los Angeles County (OLAC) Water Reuse Study (OLAC 1982)
- 1995 JOS 2010 Master Facilities Plan (Sanitation Districts 1995a)
- 1995 Plan for Beneficial Reuse of Recycled Water (Sanitation Districts 1995b)
- 2002 Southern California Comprehensive Water Reclamation and Reuse Study (United States Bureau of Reclamation [USBR] 2002)
- City of Los Angeles Integrated Resources Plan 2005
- City of Los Angeles Recycled Water Master Plan 2006
- Urban Water Management Plans (all water wholesalers and purveyors)
- Sanitation Districts Annual Status Reports on Recycled Water

Each of these documents and their findings are briefly discussed in the following sections.

4.10.2.1 Orange and Los Angeles County Water Reuse Study (1982)

This study was prepared as a cooperative effort among the following agencies: the EPA, State Water Resources Control Board (SWRCB), MWD, Sanitation Districts, City of Los Angeles Bureau of Engineering, City of Los Angeles Department of Water and Power, Orange County Water District, Sanitation Districts of Orange County, State Department of Water Resources, LARWQCB, Santa Ana Regional Water Quality Control Board, and SCAG.

The OLAC study was the first comprehensive study on water reuse for the Orange County and Los Angeles County metropolitan areas. It evaluated technical, economic, and regulatory aspects of recycled water and defined a sequence of projects that could be developed to increase the use of recycled water over a 20- to 30-year time period. The study forecasted a recycled water demand of 290,000 AFY within Orange and Los Angeles counties to be realized between 2010 and 2015.

4.10.2.2 Joint Outfall System 2010 Master Facilities Plan (1995)

This Sanitation Districts' planning document dedicated a section to the status of water recycling and water reuse. This section described the amount of recycled water available from the treatment plants and the customers of recycled water. It also projected the sizes and locations of future water reuse markets in the JOS service area.

4.10.2.3 Plan for Beneficial Reuse of Recycled Water (1995)

This Sanitation Districts plan was released in December 1995, with three stated goals:

- Identify and evaluate the potential for reuse of recycled water
- Delineate and examine technical, regulatory, and institutional impediments to using recycled water
- Propose a strategy for avoiding or overcoming the identified impediments

The last chapter of the document lists several recommended action items, including implementation of the JOS 2010 Master Facilities Plan; participation in legislative and public relations efforts to promote water recycling, management of recycled water production and distribution to optimize its availability to customers; and setting recycled water rates that encourage water reuse via savings over potable water supplies.

4.10.2.4 Southern California Comprehensive Water Reclamation and Reuse Study (2002)

This USBR study focused on the identification of regional water recycling opportunities. The study was divided into two phases. Phase I included data collection and analytical model development leading to an examination of the feasibility of regional water recycling projects across Southern California. Phase II focused on evaluating the feasibility of a number of basin-specific, multi-agency regional, and single-agency geographically localized, recycling projects. One of the study conclusions was that a total demand of 115,934 AFY and 188,520 AFY could be satisfied by the years 2010 and 2040, respectively, within the JOS service area.

4.10.2.5 City of Los Angeles Integrated Resources Plan (2005)

The Los Angeles Integrated Resources Plan was a stakeholder-driven process in which community members, agency representatives, and interested stakeholders participated in the development of alternatives to achieve the city of Los Angeles' wastewater, urban runoff, and recycled water needs.

As part of the Integrated Resources Plan development, more than 20 preliminary alternatives were developed. Four were selected for further evaluation, and one was approved for implementation (contingent upon specific citywide policy changes with respect to groundwater recharge with recycled water). A second alternative was identified in the event that such policy changes are not adopted and treatment facility expansion is needed. The selected alternative includes expansion of the Tillman WRP and has a high potential for water resources projects. The backup alternative includes the expansion of the Hyperion Treatment Plant and has a moderate potential for water resources projects.

4.10.2.6 City of Los Angeles Recycled Water Master Plan (2006)

This master plan identified and evaluated new recycled water facilities based on factors such as water demands, economics, water quality regulations, and public acceptance. The master plan divided potential recycled water customers into four areas based on their proximity to existing wastewater treatment plants: San Fernando Valley (Tillman WRP), Central City (Los Angeles-Glendale WRP), Westside (West Basin Water Recycling Facility), and Harbor (Terminal Island WRP). The Harbor area expansion from the city of Los Angeles' Terminal Island WRP included some potential industrial users that could also be served from the JWPCP; however, additional treatment of JWPCP effluent would most likely be required for these customers.

4.10.2.7 Urban Water Management Plans

The Urban Water Management Planning Act requires urban water suppliers of a specific size to prepare and adopt UWMPs. The UWMPs must be prepared in accordance with prescribed requirements established by the SWRCB including a description and evaluation of reasonable and practical efficient water uses, existing and projected uses of recycled water, and conservation activities. The most recent UWMPs were produced in 2010 by the wholesalers and purveyors located within the JOS service area. The recycled water numbers presented in the UWMPs are developed using different assumptions and serve different purposes than this document. Therefore, the direct use of such projections must be considered in context and, in some cases, revised for use in this facilities plan when evaluating the potential of future recycled water markets.

4.10.2.8 Annual Status Reports on Recycled Water

These reports are prepared for each fiscal year and include information about the Sanitation Districts' WRPs. These annual reports provide information about recycled water use by plant and information about current and future projects.

4.10.3 Chronology of Water Reuse Approvals

Over the last 30 years, there have been a number of key regulatory approvals procured by the Sanitation Districts that have contributed to the continued and increased use of recycled water. A brief chronology of these regulatory approvals is presented in the following list.

- October 1978: Revised wastewater reclamation regulations are adopted by the State Department of Health Services (DHS, now California Department of Public Health, CDPH) as Title 22 of the California Code of Regulations. The effluent from the Sanitation Districts' tertiary treatment plants can be used for all of the approved applications contained in these regulations.
- June 1981: The LARWQCB adopts Board Order No. 81-34, which establishes water reclamation requirements (WRRs) for the POWRP.
- March 1987: The LARWQCB adopts Board Order No. 87-40, which permits the increase in the use of recycled water for groundwater recharge in the Montebello Forebay from 32,700 to 50,000 AFY.
- April 1987: The LARWQCB adopts Board Order Nos. 87-47, 87-50, and 87-51, which establishes revised WRRs for the LBWRP, SJCWRP, and LCWRP, respectively.
- September 1988: The LARWQCB adopts Board Order No. 88-107, which establishes WRRs for the WNWRP.
- September 1991: The LARWQCB adopts Board Order No. 91-100, which permits the increased use of recycled water for groundwater recharge in the Montebello Forebay to 60,000 AF in any 1 year, with a maximum of 150,000 AF in any 3-year period.
- May 1997: The LARWQCB readopts all of the Sanitation Districts' water reuse permits that had been previously issued in the 1980s in Board Order No. 97-072.
- December 2000: DHS adopts revised Title 22 Water Recycling Criteria that contains an expanded list of approved direct, non-potable uses of recycled water.
- June 2001: DHS issues draft Groundwater Recharge Regulations to Title 22 Water Recycling Criteria.
- September 2005: The LARWQCB adopts Board Order No. R4-2005-0061, which permits the use of advanced treated recycled water from the LBWRP for injection into the Alamitos Seawater Intrusion Barrier.
- August 2008: DHS issues revised draft Groundwater Recharge Regulations.
- April 2009: The LARWQCB adopts Board Order No. R4-2009-0048, which eliminates the annual and running 3-year volumetric limits on recycled water contribution to recharge contained in Board Order No. 91-100, replacing them with a dilution requirement of 35 percent recycled water in any 60-month period.

Currently, the CDPH, LARWQCB, and the Los Angeles County Department of Public Health (County DPH, formerly County DHS) or local health agencies, where applicable, have regulatory and/or oversight responsibilities for irrigation and industrial reuse applications. For groundwater recharge, beyond the general state regulations (Title 22 guidelines), permits from the LARWQCB would likely have specific requirements based on water quality and basin objectives. Detailed information on current water reuse regulations is contained in Chapter 3 of this document.

4.10.4 Current Reuse

The current status of water recycling and treatment plant conditions were presented in the most recent Annual Status Report on Recycled Water (Sanitation Districts 2011). The document presents a summary of the current projects for each of the Sanitation Districts' WRPs and lists start-up dates, acreages, type of users, and usage amounts. Data from this report are presented in Table 4-14 and on Figures 4-10 through 4-14.

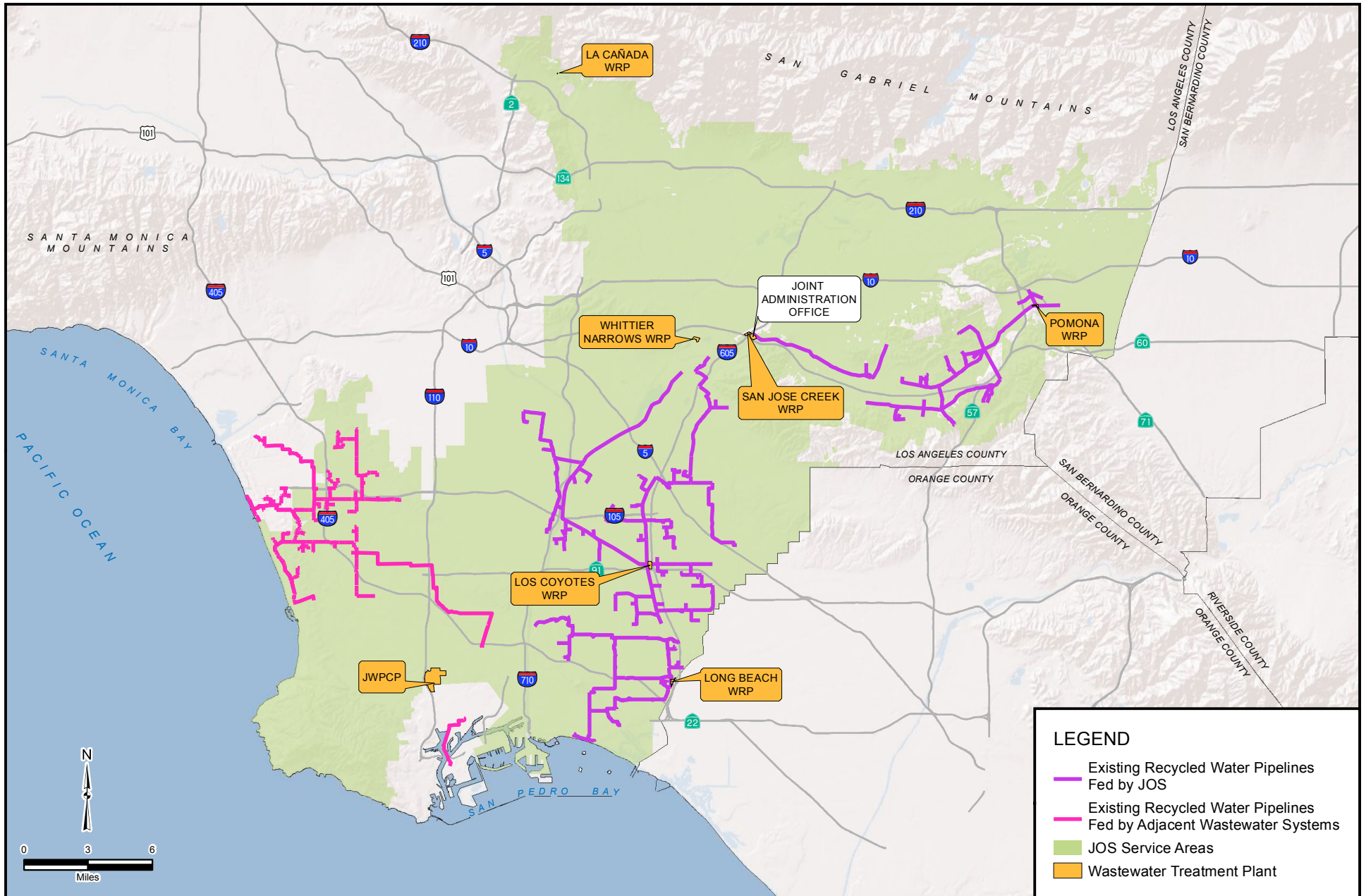

LEGEND

- Existing Recycled Water Pipelines Fed by JOS
- Existing Recycled Water Pipelines Fed by Adjacent Wastewater Systems
- JOS Service Areas
- Wastewater Treatment Plant

FIGURE 4-10

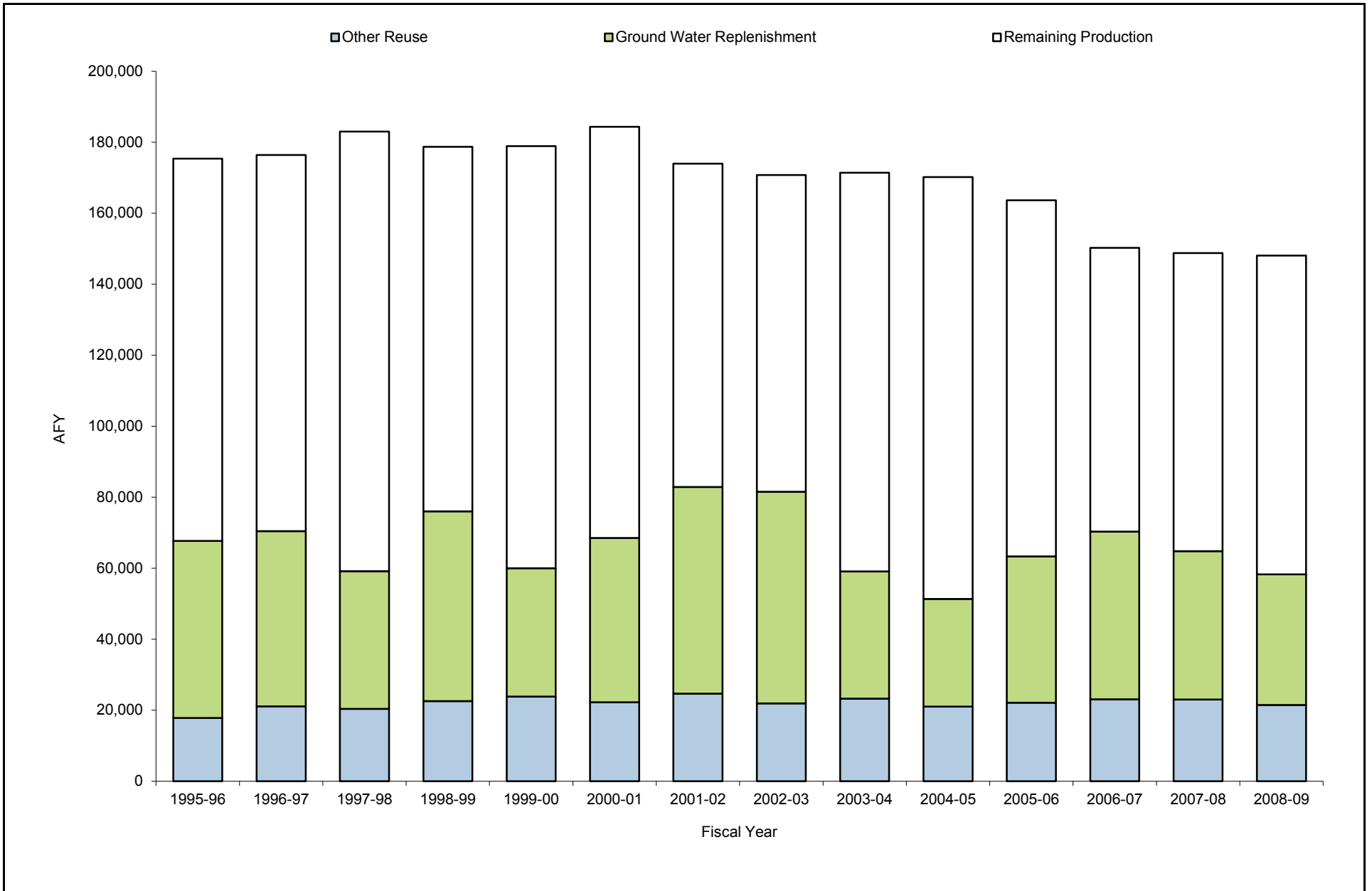

FIGURE 4-11



Historical Recycled Water Production and Total Usage

Source: Sanitation Districts of Los Angeles County 2011

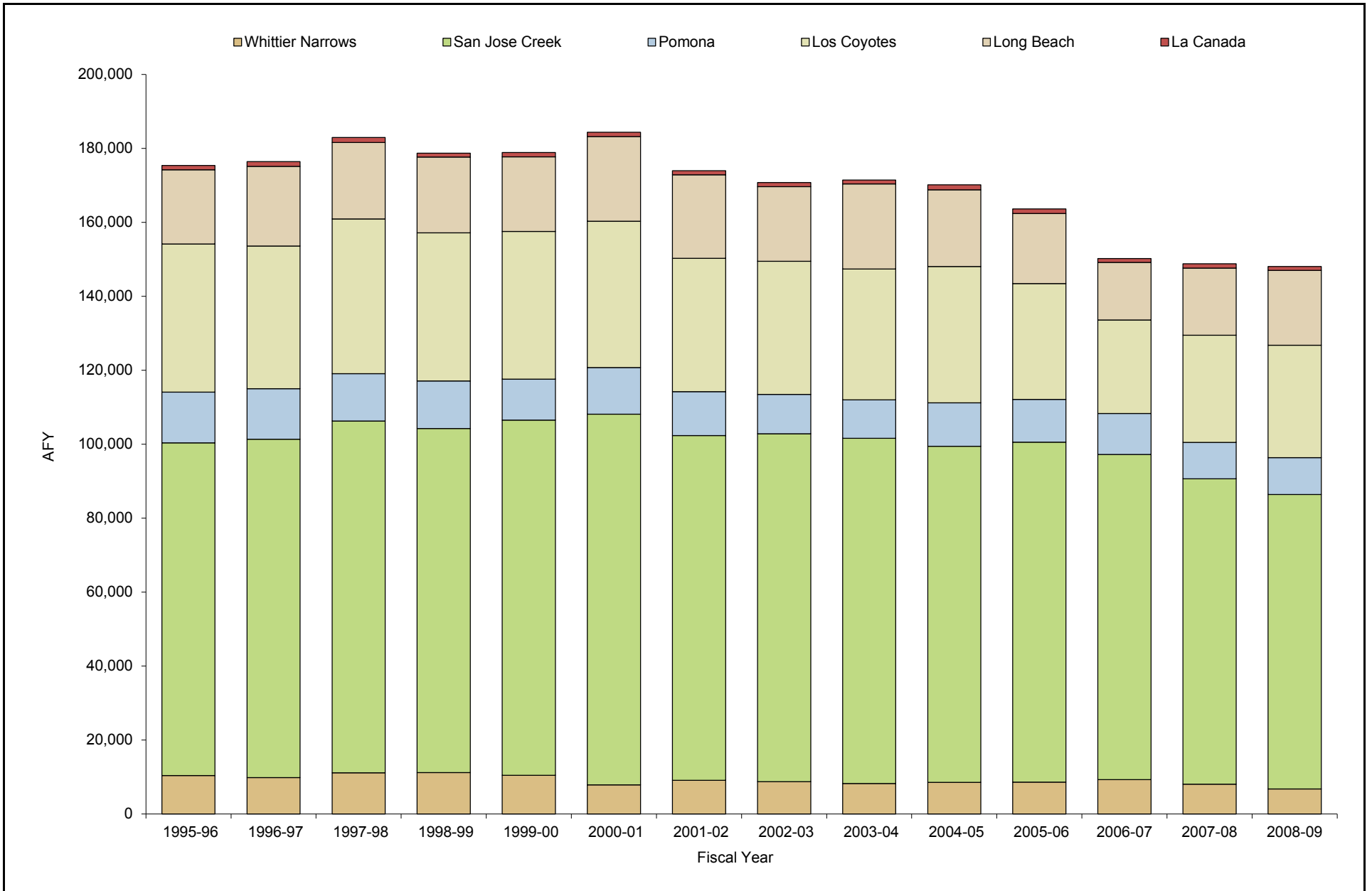

FIGURE 4-12



Historical WRP Recycled Water Production

Source: Sanitation Districts of Los Angeles County 2011

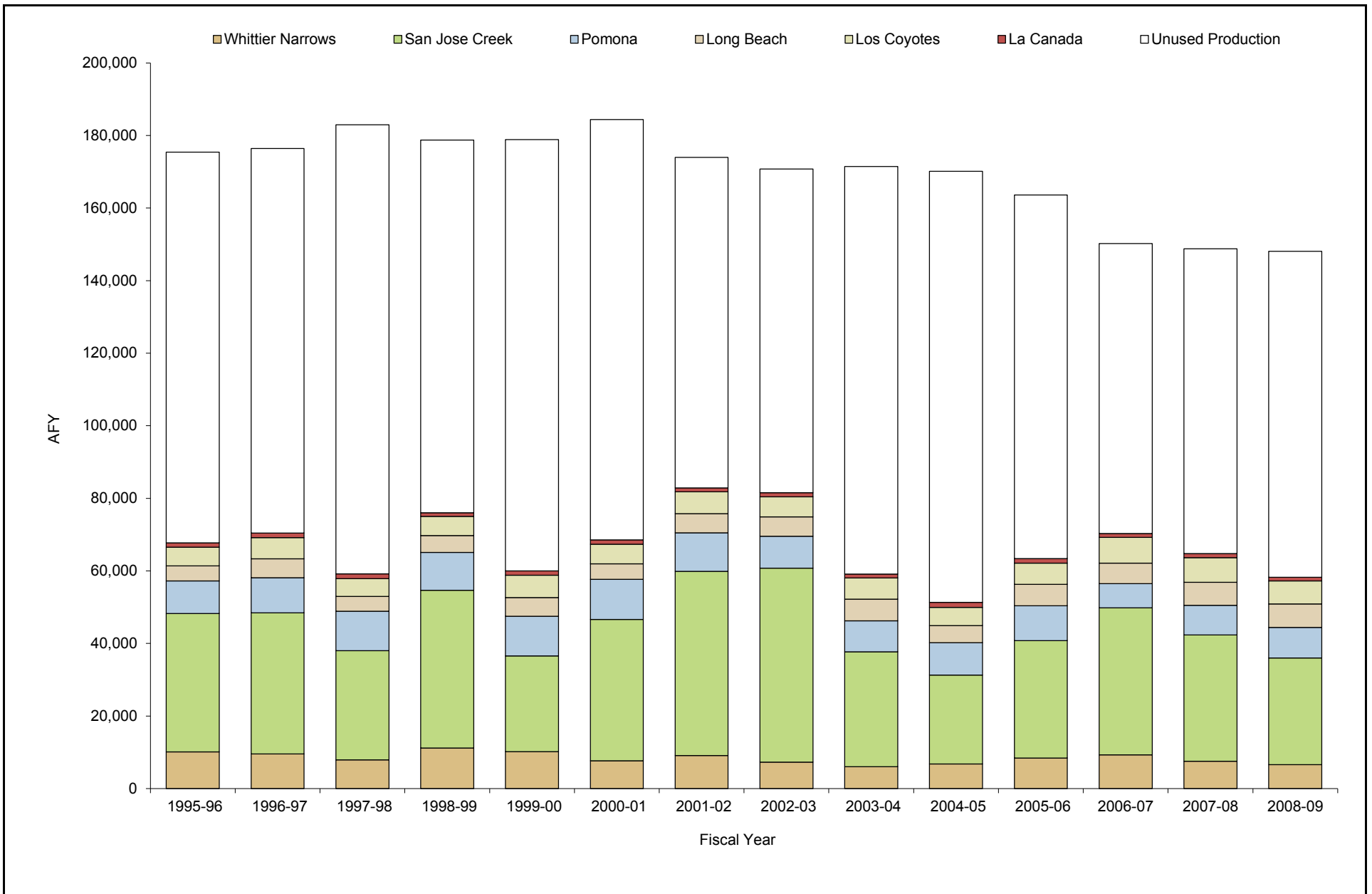

FIGURE 4-13



Historical Recycled Water Usage by WRP

Source: Sanitation Districts of Los Angeles County 2011

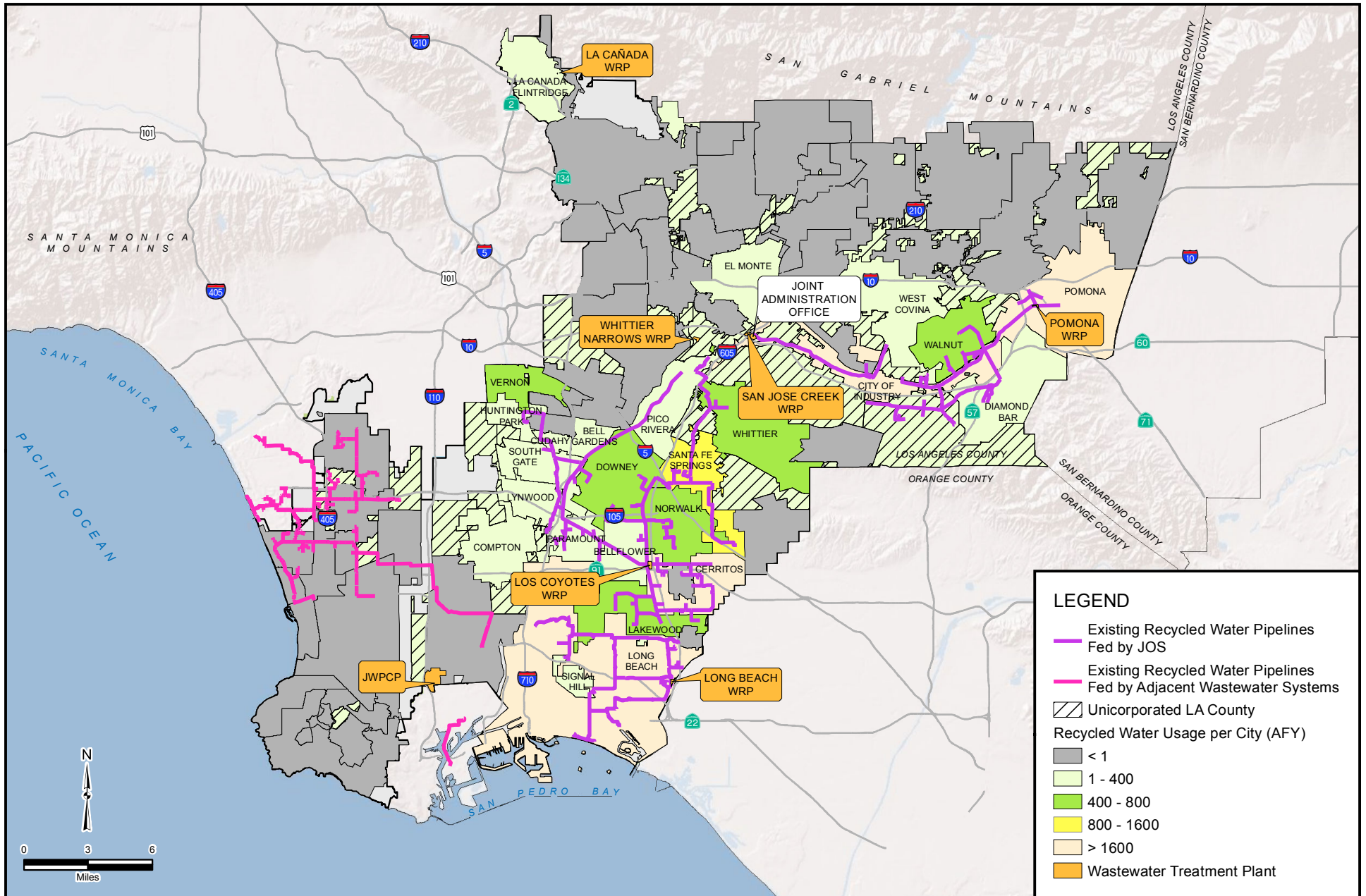

FIGURE 4-14

The location of the WRPs and the current recycled water pipelines within the JOS service area and in the immediate surrounding vicinity are shown on Figure 4-10.

The capacity, production, water reuse amount, and number of water reuse sites per WRP within the JOS drainage area for fiscal year 2009–10 are presented in Table 4-14. Processing at all the WRPs, with the exception of the LACAWRP, includes secondary treatment using activated sludge systems followed by tertiary filtration and disinfection. The percentage of recycled water that is reused by each plant is shown in Table 4-14.

Historical recycled water production and recycled water usage within the JOS are shown on Figure 4-11. The WRPs within the JOS have produced between 139,000 and 180,000 AFY of recycled water for most of the last 10 years. Recycled water usage has ranged between 50,000 and 80,000 AFY. Over the past 10 years, on average, approximately 40 percent of the recycled water produced has been reused in the JOS service area.

Table 4-14. Reuse by WRP for Fiscal Year 2009–10

Water Reclamation Plant	Permitted Capacity (MGD)	Water Produced		Water Reused		Percent Reused	Number of Reuse Sites
		Daily Avg. (MGD)	Annual (AFY)	Daily Avg. (MGD)	Annual (AFY)		
POWRP	15.0	8.4	9,400	7.4	8,200	88%	192
SJCWRP	100.0	68.6	76,800	44.0	49,300	64%	84
WNWRP	15.0	4.7	5,300	4.7	5,300	100%	3
LCWRP	37.5	24.2	27,100	5.2	5,900	22%	273
LBWRP	25.0	18.3	20,500	5.8	6,600	32%	56
LACAWRP	0.2	0.1	100	0.1	100	100%	1
Total	192.7	124.3	139,200	67.2	75,400	54%	609

MGD = million gallons per day
 AFY = acre-feet per year
 Source: Twenty-first Annual Status Report on Recycled Water, Fiscal Year 2009–10 (Sanitation Districts 2011)

Recycled water usage peaks between the 2001–02 and 2003–04 fiscal years are also shown on Figure 4-11. The peak usage in fiscal year 2001–02 was due to a combination of increased irrigation and groundwater replenishment. Dry weather and high temperatures in these years resulted in a significant increase of recycled water use for urban landscaping irrigation. The increase in groundwater recharge was due the conditions from previous years and the attempt to bring the 3-year total up to the permitted limit of 150,000 AF. The significant decrease in usage in fiscal year 2003–04 was due to reductions in groundwater recharge as compared to previous years, again to comply with the 3-year permitted limit of 150,000 AF.

Yearly recycled water production broken down by plant is presented on Figure 4-12. The SJCWRP has the highest production within the JOS service area. The maximum production since 1995 was 183,000 AF in fiscal year 2000–01. The maximum usage, 82,000 AF, occurred in fiscal year 2001–02.

The historical usage and the produced recycled water that was unused and discharged to surface waters by WRP are shown on Figure 4-13. A significant difference between the amount of water that is produced and the amount that is reused is shown on the figure. Much of that difference is explained by the seasonality of WRP inflows. The WRPs are more likely to receive and produce more flow during the winter due to rainfall runoff entering the sewer system while demands for recycled water are at a minimum. Flows not utilized to meet recycled water demands are ultimately released into the ocean via

the San Gabriel River and its tributaries. However, a significant amount of the discharge from the SJCWRP, WNWRP, and POWRP is conserved via groundwater recharge, even during the rainy season.

Besides the seasonal variation on demands, there is also a diurnal flow variation that affects the degree to which recycled water flows can be used. The WRPs were mainly designed to treat residential and commercial wastewater, and, therefore, peaks of flow occur between 8:00 a.m. and 10:00 p.m. corresponding to human activity. However, a major use of recycled water is for landscaping irrigation where peaks of demand occur during the night when evaporation is lower and public greenbelt areas (e.g., parks, schools, golf courses) are unoccupied. Typically, the flows and capacities of the WRPs are adequate to meet the diurnal demands of recycled water customers. In the event of increased demand for recycled water, increased flow equalization and/or recycled water diurnal storage facilities at some WRPs or within the water wholesalers/purveyors distribution system could be required.

The current recycled water usage over city areas within the JOS is shown on Figure 4-14. Typically, where infrastructure is available, there is significant recycled water use, as shown on the figure.

Another major user of the Sanitation Districts' recycled water is the Water Replenishment District of Southern California (WRD). The WRD purchased 4,600 AFY from the WNWRP and 44,000 AFY from the SJCWRP in fiscal year 2009–10. It is noteworthy that the largest use (58 percent) of recycled water from the Sanitation Districts' WRPs is for groundwater replenishment.

Groundwater recharge takes place in the Montebello Forebay spreading grounds adjacent to the Rio Hondo and the San Gabriel River. According to the requirements established by the LARWQCB detailed in Board Order No. 91-100, adopted on September 9, 1991, the WRD had been permitted to spread up to 60,000 AFY of recycled water in any given year, not to exceed 50 percent of the total inflow to the Montebello Forebay in that year. However, as noted previously, this permit was revised by the LARWQCB in April 2009 to allow recycled water to make up to 35 percent of the total inflow into the forebay during any 60-month period (Sanitation Districts 2011). This new permit requirement, while allowing for increased amounts of recycled water use, still limits the amount of groundwater recharge that can be achieved using recycled water. In addition, the Sanitation Districts have had to make continuous adjustments to their operations and discharges to meet water quality requirements that continue to evolve.

4.10.5 Future Reuse

A number of potential projects that may be developed in the future have been identified that may expand reuse opportunities within the JOS. Most of the information on future projects was found in the following documents: the Annual Status Report on Recycled Water (Sanitation Districts 2010, 2011) and the Summary of Recycled Water Plans within the County Sanitation District of Los Angeles County's (CSDLAC's) Service Area (LWA 2007), a compilation of information on recycled water projects from the 2005 UWMPs, Integrated Regional Water Management Plans, Integrated Watershed Management Programs, and the city of Los Angeles' Recycled Water Master Plan.

The following subsections provide a brief description of some potential major future projects in the JOS service area, summarized by the WRP that would provide the recycled water.

4.10.5.1 Pomona Water Reclamation Plant

The Walnut Valley Water District (WVWD) has identified approximately 4,550 AFY of additional recycled water demand for the proposed expansion of its recycled water distribution system (Sanitation

Districts 2011). It is expected that approximately 3,000 AFY of these demand could be realized by 2050, primarily from customers in Walnut Village and the city of Diamond Bar.

The city of Pomona's major recycled water user was a paper company, with an average annual recycled water demand of approximately 3,700 AFY that had remained fairly constant since 1992. However, this facility ceased operations and stopped taking recycled water in April 2007. The city has identified 900 AFY of near-term demand and 700 AFY of longer-term demand that could use a portion of this available recycled water by 2050, if funding sources to extend recycled water pipelines to these customers can be obtained.

4.10.5.2 San Jose Creek Water Reclamation Plant

A total of 23,000 AFY of recycled water was proposed to be diverted for advanced treatment from SJCWRP West to supply Phase 1 of the Groundwater Reliability Improvement Program (GRIP). A total of 18,000 to 46,000 AFY of product water was planned to be split between the WRD and Upper San Gabriel Valley Municipal Water District (USGVMWD) for replenishment of the Central and Main San Gabriel groundwater basins, respectively (Sanitation Districts 2011). However, in February 2011, the USGVMWD Board of Directors voted to remove USGVMWD from the GRIP Joint Powers Agreement in order to explore other means of using recycled water for recharge of the Main San Gabriel Basin. GRIP Phase 1 is still under consideration, but its size and scope may be reduced.

The expansion of the city of Industry's recycled water pipeline by the USGVMWD and the Rowland Water District is expected to serve approximately 7,600 AFY from the SJCWRP East by 2020 to customers in the Rowland Water District, Suburban Water Systems, the WVWD, and the city of Industry.

The Central Basin Municipal Water District's (CBMWD's) Southeast Water Reliability Project would loop the Rio Hondo (Torres) and Century (Ibbetson) systems for flow reliability via a pipeline being built from the city of Pico Rivera through the cities of Montebello, Commerce, and East Los Angeles to the city of Vernon. This would allow recycled water to be supplied to these systems from both the LCWRP and SJCWRP. However, hydraulic limitations may exist that could control how much supply could be served from either plant at a given time. Also, water quality differences between the two sources could impact how much recycled water can be used from either plant based on user needs. This project is expected to deliver 4,000 AFY in the near-term and another 2,400 AFY by 2050.

Effluent from this plant that is not delivered through any direct distribution system is discharged into the San Jose Creek or San Gabriel River for groundwater recharge of the Central Basin by the WRD.

4.10.5.3 Whittier Narrows Water Reclamation Plant

One major project is expected to be supplied from the WNWRP. This project is part of the USGVMWD's San Gabriel Valley Water Recycling Project - Phase III to serve potential irrigation customers in the cities of South El Monte, El Monte, Irwindale, and Arcadia. This project would include connections to the Santa Anita Racetrack, the Los Angeles County Arboretum, Arcadia High School, Los Angeles County's Santa Anita Golf Course, and other greenbelt areas. Approximately 740 to 2,000 AFY of recycled water has been identified for this project (Sanitation Districts 2010, 2011). Preliminary design efforts have been completed within the city of Arcadia, and the USGVMWD is completing a master plan of the area to focus preliminary design efforts for the project.

Effluent from this plant that is not delivered through any direct distribution system is discharged into the Rio Hondo or San Gabriel River for groundwater recharge of the Central Basin by the WRD.

4.10.5.4 Los Coyotes Water Reclamation Plant

The LCWRP supplies both the city of Cerritos' recycled water distribution system and the CBMWD's Century (Ibbetson) System, the latter currently distributing recycled water to the cities of Bellflower, Bell Gardens, Compton, Downey, Lakewood, Lynwood, Norwalk, Paramount, Santa Fe Springs, South Gate, and Vernon. CBMWD has recently begun exploring the possibility of expanding its existing system by approximately 1,200 to 1,500 AFY (Sanitation Districts 2010, 2011).

The city of Cerritos is currently a major user of LCWRP recycled water. The city could expand their recycled water use by approximately 140 AFY by 2030 (LWA 2007).

The city of Lakewood is considering an expansion of approximately 100 to 160 AFY to its recycled water distribution system, which is supplied from the Cerritos system (Sanitation Districts 2010, 2011).

4.10.5.5 Long Beach Water Reclamation Plant

The LBWRP has a current water reuse level close to 7,000 AFY. The Long Beach Water Department (LBWD) has identified approximately 6,000 to 7,000 AFY of additional recycled water demand for irrigation and industrial uses (Sanitation Districts 2010, 2011), and may implement phased-in expansions of their recycled water distribution system to reach these sites, depending on funding and the availability of recycled water at the LBWRP. The LBWD is also working with the WRD to supply approximately 4,000 AFY of additional recycled water for expanded operation of the Alamitos Barrier Recycled Water Project (LWA 2007).

4.10.5.6 La Cañada Water Reclamation Plant

All of the recycled water produced at the LACAWRP is currently being reused, and there are no new projects planned for the recycled water produced at the LACAWRP.

4.10.5.7 Joint Water Pollution Control Plant

The Sanitation Districts and the MWD are conducting a joint feasibility study to evaluate the replenishment and storage capacities of area groundwater basins with the potential to recycle 100 MGD (112,000 AFY), or more, of JWPCP effluent. The JWPCP effluent would need to undergo advanced treatment, which is not currently in place, prior to recharging the groundwater. As part of the study, a pilot plant comprising ultrafiltration/reverse osmosis (UF/RO) and membrane bioreactor/reverse osmosis (MBR/RO), both followed by ultraviolet irradiation/oxidation, has been operating at the JWPCP since July 2010 for the UF/RO and November 2010 for the MBR/RO. The feasibility study will also evaluate how this project could complement other proposed projects, including GRIP and the city of Los Angeles' Recycled Water Master Plan.

4.10.5.8 Summary of Future Demands

Total future low and high projections of recycled water reuse demands within the JOS by WRP are shown in Table 4-15. Low reuse projections are based on projects with a higher likelihood of being completed within the 2050 planning horizon. High reuse projections are based on the low projections plus conceptual projects that are much more technically, institutionally, and financially complicated and may require significant capital improvements at the WRPs to implement.

Table 4-15. Summary of Total Projected Recycled Water Use Within the JOS by 2050

Water Reclamation Plant	Total Projected Annual Reuse (AFY) ^a	
	Low Projection	High Projection
POWRP	16,000	17,000
SJCWRP	85,000	140,000
WNWRP	15,000	15,000
LCWRP	7,000	28,000
LBWRP	12,000	18,000
LACAWRP	100	100
Total	135,100	218,100

^a Values rounded and based on projected future recycled water projects.

4.10.6 Reuse Challenges

A number of challenges exist relative to the expanded use of recycled water produced within the JOS service area in the following areas:

- **Delivery Systems:** Current uses are closely tied to the existing recycled water delivery infrastructure. Additional users could require expansion of current systems (i.e., piping, pumping stations, and storage facilities), which may represent a significant capital investment.
- **Supply Availability:** As the demand for recycled water increases, there may be insufficient supply available at specific locations. In some cases, the shortfall may be a result of the diurnal variations between supply (peak flow into the WRPs) and demand (peak irrigation requirements, particularly during the summer months).
- **Quality:** Future users may require higher levels of water quality than currently available at existing facilities. An example may be the need for recycled water with lower TDS levels for such industrial processes as boiler feed. These types of water quality requirements could result in higher levels of treatment in the future.

Chapter 5

EXISTING FACILITIES DESCRIPTION AND NEEDS ASSESSMENT

5.1 Joint Outfall System Overview

The Sanitation Districts of Los Angeles County's (Sanitation Districts') Joint Outfall System (JOS), shown on Figure 5-1, consists of seven wastewater treatment plants, over 1,230 miles of sewers, and 50 pumping plants. The largest JOS treatment facility is the Joint Water Pollution Control Plant (JWPCP). The other facilities are water reclamation plants (WRPs) that draw from the upstream reaches of the collection system and produce effluent suitable for reuse. The JOS WRPs include the Pomona Water Reclamation Plant (POWRP), San Jose Creek Water Reclamation Plant (SJCWRP), Whittier Narrows Water Reclamation Plant (WNWRP), Los Coyotes Water Reclamation Plant (LCWRP), Long Beach Water Reclamation Plant (LBWRP), and La Cañada Water Reclamation Plant (LACAWRP). In addition to producing effluent suitable for reuse, the WRPs can bypass all or a portion of their influent flows to the JWPCP for treatment. Solids produced at the WRPs are sent to the JWPCP for centralized processing.

5.2 Conveyance System

The conveyance system comprises four types of sewers. Ranging from the smallest to the largest, these are:

- Lateral lines
- Local sewers
- District trunk sewers
- Joint Outfall (JO) trunk sewers

In general, wastewater generated within the JOS flows from the smallest lines (laterals and local sewers), through the next largest lines (district trunk sewers), and finally into the largest lines (JO trunk sewers). The JO trunk sewers are tributary to one of the WRPs and/or to the JWPCP. The length of the sewer lines within the JOS boundaries (excluding lateral lines), broken down by sewer type and individual district, is provided in Table 5-1.

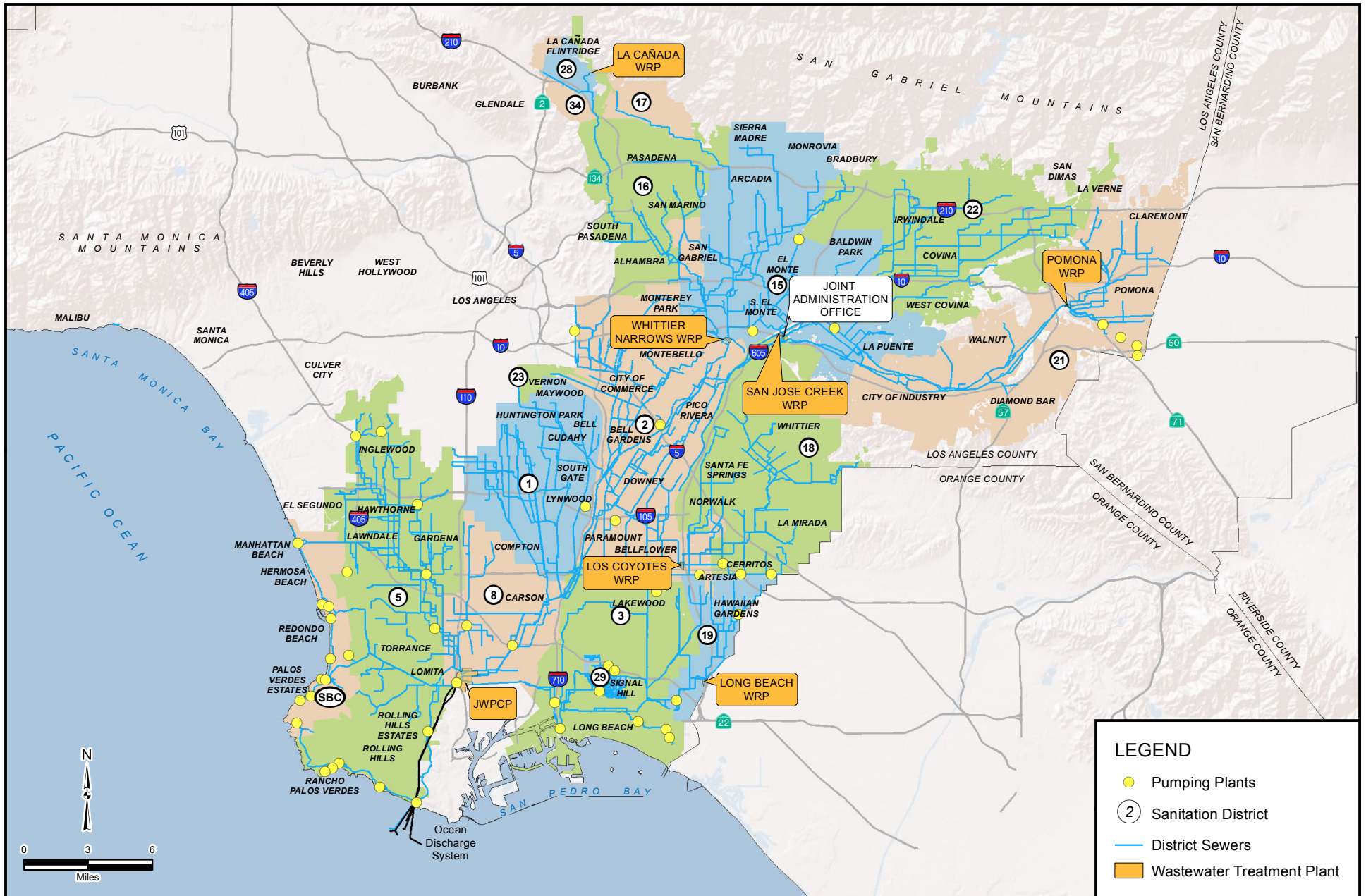

FIGURE 5-1

Joint Outfall System

Table 5-1. Lengths of Sewers Located in Each District

District No.	Local Sewers (miles)	District Trunk Sewers (miles)	JO Trunk Sewers (miles) ^a
1	697	69	31
2	976	125	90
3	788	27	45
5	1,098	128	61
8	292	38	47
15	1,028	62	80
16	539	30	17
17	108	5	0
18	726	69	17
19	199	15	19
21	961	51	34
22	732	75	26
23	21	0	2
28	35	2	2
29	1	38	2
34	1	0	0
SBC	277	19	6
Total	8,479	753	480

^a Does not include 30 miles of outfalls (lines that convey treated effluent).

5.2.1 Laterals and Local Sewers

The majority of sewer lines located within the JOS service area are the responsibility of private property owners or local jurisdictions. The privately owned lateral lines connect residences and business to the local sewer, which are operated and maintained by either the cities in which the lines are located or Los Angeles County's Consolidated Sewer Maintenance District (within the Department of Public Works).

5.2.2 District Trunk Sewers

District trunk sewers are owned, operated, and maintained by the individual districts in which they are located. The purpose of most of these lines is to collect wastewater from the local sewers and/or laterals and convey it to the larger JO trunk sewers.

5.2.3 Joint Outfall Trunk Sewers

JO trunk sewers form the backbone of the JOS conveyance system. These sewers are owned, operated, and maintained by the Joint Outfall Districts, which are the 17 independent districts within the JOS. The JO trunk sewers collect wastewater from the district trunk sewers or local sewers and convey it to one of the WRPs or the JWPCP for treatment and disposal. There are nine JO trunk sewer lines designated Joint Outfall A to Joint Outfall J. (There is no Joint Outfall I.) The JO trunk sewers are shown on Figure 5-2 and listed by district in Table 5-1 and by JO sewer line in Table 5-2.

Table 5-2. Lengths of District Trunk Sewers

Joint Outfall Trunk Sewers	Length (miles)^a
Joint Outfall A	108
Joint Outfall B	102
Joint Outfall C	45
Joint Outfall D	23
Joint Outfall E	16
Joint Outfall F	24
Joint Outfall G	13
Joint Outfall H	114
Joint Outfall J	35
Total	480

^a Does not include 30 miles of outfalls (lines that convey treated effluent).

5.2.4 Management Practices

5.2.4.1 Current System Operations

While the vast majority of the conveyance system is in continuously active service, there are several trunk sewers that are available but kept inactive for portions of the year. A few of these sewers are routinely returned to service, but most would require a significant amount of rehabilitation to keep in full time service. These are generally sewers that have been taken out of service when a new replacement sewer is constructed, but not permanently abandoned because their condition allows for their potential use. Some of these sewers are bulkheaded, or blocked off, and designated out of service but can be placed back into service; others are designated active in emergencies only and are available for use as needed (e.g., for wet weather flow management). During dry weather periods when extra capacity is not required, the Sanitation Districts minimize the use of inactive trunk sewers, thereby reducing maintenance costs.

Prior to each wet season, the JOS system configuration is slightly modified to take advantage of the additional capacity by adjusting stop logs, gates, and other flow control devices in the system. Once the projects that have been identified to provide the currently needed hydraulic relief are in place, wet season adjustments would be minimal because the capacity constraints that would trigger the adjustments will have been addressed.

Relief lines are typically designed to convey the ultimate design flows in conjunction with continued use of the existing sewer. Replacement lines are designed to provide the full ultimate design flow capacity; the existing lines can then be taken out of service, providing backup and flexibility for sewer system operations, such as wet weather flow management.

5.2.4.2 Condition Assessment and Improvements

The Sanitation Districts routinely monitor and evaluate individual sewer segments using closed-circuit television and physical inspections, as well as flow and level monitoring. Identified system deficiencies are addressed through sewer relief, repair, rehabilitation, and replacement projects. Therefore, the JOS conveyance system is in a continuous state of change as a balance is maintained between the aging of existing infrastructure and the implementation of sewer projects.

For decades, the Sanitation Districts have implemented a comprehensive program for identifying and relieving sewer capacity constraints. An element of this program includes the Sewer System Evaluation and Capacity Assurance Plan (SSECAP), which is now part of the Sewer System Management Plan (SSMP). The SSMP is required under the State Water Resources Control Board's (SWRCB's) Order No. 2006-0003 (Statewide General Waste Discharge Requirements for Sanitary Sewer Systems) (WDR Order No. 2006-0003).

As required by WDR Order No. 2006-0003, Subsection D.1(viii), the SSECAP results in a capital improvement plan (CIP) that "will provide hydraulic capacity of key sanitary sewer system elements for dry weather peak flow conditions, as well as the appropriate design storm or wet weather event." As part of the SSECAP, the sewer system is evaluated for hydraulic deficiencies, design criteria are established or enhanced as necessary, analysis is undertaken to establish short- and long-term CIP projects that address hydraulic deficiencies, and the identified CIP projects are scheduled.

The SSMP and SSECAP remain in draft status and are audited every 2 years and updated every 5 years. The following reports and procedures comprise the current Sanitation Districts' SSECAP:

- Capacity Conditions Assessment Report
- Description and Evaluation of Capacity Assessment Procedures
- Capacity Assurance Plan
- Report of Recommended Facility Improvements

Key findings found in each of these documents are incorporated into the most recent CIP.

5.2.4.3 Wet Weather Flow Management

Unlike many older parts of the United States that have combined sewer systems, most wastewater conveyance systems in Southern California, including that for the JOS, are separate from the storm drain system. Even so, the extent to which wet weather infiltration and inflow (I/I) affects the performance of the conveyance system is directly related to rainfall patterns. During normal or dry years, the volume of I/I is typically low; however, it increases in wet years. This increased I/I loading can lead to wet weather-related wastewater spills.

While the Sanitation Districts' design criteria for sewer sizing provide excess capacity to accommodate wet weather flow, approximately 87 percent of the total sewer system within the JOS service area is composed of local sewers outside the Sanitation Districts' purview. (Note that this percentage would be even higher if it were to include the privately owned laterals that connect residences and businesses to the local sewers.) As such, the Sanitation Districts can exert little direct control over the majority of sources of I/I. Therefore, I/I is a challenge that requires region wide collaboration. Nevertheless, the Sanitation Districts recognize that limiting the amount of I/I that enters into the sewerage system is a best practice to minimize sanitary sewer overflows and wastewater treatment costs.

The Sanitation Districts have instituted the following industry best management practices to reduce I/I:

- Conducting regular sewer system condition assessments
- Identifying, then rehabilitating and/or replacing deteriorated sewers
- Plugging manhole cover pick holes and sealing manhole cover frames subject to inflow
- Raising manhole covers in unimproved areas so that the cover is above the high water level

- Installing watertight caps on uncapped cleanouts
- Identifying and disconnecting illegal connections to the sewer system

Furthermore, the Sanitation Districts are actively engaged with the Los Angeles County Department of Public Works and the cities in the JOS service area to reduce I/I from entering local sewers. The Sanitation Districts have provided cork stoppers and silicone sealants for manholes to member cities free of charge. The Sanitation Districts are coordinating with local jurisdictions to educate public works employees that the practice of removing manhole covers as a means of flood control results in additional inflow into the sewer system and potential wastewater spills.

The wet-weather peaking factor (i.e., the increase in flows seen during and following major rain events) is approximately two times the average flows for the JOS.

The Sanitation Districts' current conveyance system management practices provide sufficient I/I control to compensate for sewerage infrastructure aging and deterioration. Therefore, additional I/I reductions that may be realized by these programs were not factored into the wet weather flow projections.

5.2.4.4 Storm Drain Diversion Management

Historically, sanitary agencies, including the Sanitation Districts, have not accepted urban runoff flows from the storm drains into their sanitary conveyance systems, which are separate systems. The reasons for this are to avoid (1) impacts from constituents in the runoff that could cause problems with the treatment processes and negatively impact the ability to meet effluent discharge requirements and (2) hydraulic capacity issues and the possibility of causing system overflows. More recently, consideration has been given to treating portions of the storm drain flows through publicly owned treatment works (POTWs) during periods of low flow within the sanitary systems. Low flow periods typically coincide with dry weather months and during non-peak hours of the day. This approach reduces the pollutant load from storm drain discharges to the ocean, providing benefits in terms of enhanced water quality.

Background

When areas become urbanized, much of the native ground surface is replaced by impervious paved surfaces. Water that was once absorbed into the ground then collects on these paved surfaces and flows into catch basins, storm sewers, and flood control channels, eventually makes its way out to the ocean. Wet weather urban runoff (WWUR) is generated when rainwater flows over urban surfaces such as rooftops, streets, and landscaping. Dry weather urban runoff (DWUR) is generated primarily through urban outdoor water use (e.g., landscape irrigation, car washing, and water pipe leaks). Both WWUR and DWUR can carry a number of pollutants including, but not limited to, oil and grease, sediments, nutrients, household chemicals, air pollutants captured in rainwater, pathogens, and pesticides. Urban runoff is a major source of pollution to the beaches and near-shore waters.

In 2007, the Sanitation Districts completed a report titled Supplemental Characterization of Los Angeles County Storm Drains. The study investigated the feasibility of diverting DWUR into the sewerage system or the use of alternative treatment for these flows. The report includes a listing of major storm drains with the potential for either diversion or treatment.

Sanitation Districts' Policy on Diversions

The Sanitation Districts do not accept WWUR into the sewerage system pursuant to the policy outlined in Guidelines for the Discharge of Rainwater, Stormwater, Groundwater, and Other Water Discharges (Sanitation Districts 2011). This policy was established under the provisions of Section 305 of the

Wastewater Ordinance, as amended in 1998. The Sanitation Districts require roofing and/or grading of open areas with possible connections to the sanitary sewer such that all WWUR is conveyed to the storm drain. If complete segregation is not feasible, the first 1/10 inch of rainwater may be discharged to the sanitary sewer by actively pumping from a pump well. Note that this initial 1/10 inch of rainfall on exposed industrial process areas is considered industrial wastewater and not WWUR. Rainfall above 1/10 inch must be diverted to the storm drain with an automatic rainwater diversion system that shuts down the pump and allows the rainwater to passively overflow from the pump well into the storm drain system. The Sanitation Districts currently permit approximately 400 of these rainwater diversion systems in their service area, which can equate to a total of approximately 5 MGD of flow into the conveyance system. Based on historical rainfall records, 36 rainfall events equal to or in excess of 1/10 inch are assumed to occur per year, resulting in a total of approximately 1,825 million gallons per year (MGY) of flow into the conveyance system.

The Industrial Waste Section of the Sanitation Districts has developed a policy for DWUR diversions titled Dry-Weather Urban Runoff Diversion Policy, dated July 2, 2007. The preamble provides a summary of the policy's intent:

In the interest of promoting better health and safety protection for those who engage in water contact activities in coastal areas bordered by the Sanitation Districts' service area, the Sanitation Districts have consented, where justified, to accept the diversion of dry-weather urban runoff into the sewer system.

The policy includes a listing of general requirements that apply to all diversions. Some of the major provisions include:

- All diversions must obtain an Industrial Wastewater Discharge Permit, comply with the Sanitation Districts' Wastewater Ordinance, and identify all National Pollutant Discharge Elimination System (NPDES) permitted flows tributary to the diversion point.
- Discharges are typically limited to the dry season, defined as May 1 to September 30 (though some exceptions are possible). Dry season discharges may only take place during non-peak times of day.
- Discharges are required to be pumped into the system and must receive pretreatment for trash and sediment removal. Rain detectors must also be installed for automatic pump shutdown.
- Appropriate sampling and testing must take place to ensure there are no constituents present in the storm drain flow that would have detrimental impacts on the Sanitation Districts' ability to meet discharge requirements.
- Sanitation Districts' personnel must have unencumbered access to the power source or controls.

The provisions of this policy are designed to substantially reduce the risks to the Sanitation Districts of either the entry of undesirable constituents into the system and the associated effluent quality impacts, or the acceptance of excessive flow volumes that can result in capacity issues/overflows within the system. These limited risks are offset by the substantial, continuous benefits of water quality improvements resulting from DWUR diversions.

Permitted Urban Runoff/Storm Drain Diversions

The Sanitation Districts currently accept dry weather storm drain diversions from 10 permitted diversion structures within its service area along the coast: Herondo Street in Hermosa Beach; Avenue I in Redondo Beach; Los Alamitos, Claremont, and Appian Way in Long Beach; and 28th Street, Pollywog

Park, and the Pier in Manhattan Beach. The specifics of these diversions are presented in Table 5-3. Several additional coastal projects are currently under consideration. All of the existing and proposed diversion locations are tributary to the JWPCP.

Table 5-3. Permitted Dry Weather Storm Drain Diversions

Facility Name	Physical Location	Comments	Average Daily Flow Discharged (GPD)	Peak Flow Discharged (GPM)	Allowed Discharge
Los Angeles County DPW/ Flood Maintenance Division (Alamitos Bay)	5425 Ocean Long Beach, CA 90803	Connect to: 8-inch diameter local sewer line on Ocean Blvd	29,000	120	24 hrs per day year round
City of Manhattan Beach (Manhattan Beach)	1 The Strand Manhattan Beach, CA 90266	Connect to: South Bay Cities Main Trunk (MH 30-0025)	6,200	15	24 hrs per day year round
Los Angeles County DPW/ Flood Maintenance Division (Polliwog Park)	1611 Manhattan Beach Manhattan Beach, CA 90266	Connect to: 18-inch diameter local sewer line running east- west in Manhattan Beach Blvd, between Redondo St. and Peck Ave	30,000	50	24 hrs per day year round
Los Angeles County DPW/ Flood Maintenance Division (Esplanade/Avenue I)	1621 Esplanade Redondo Beach, CA 90277	Connect to: 12-inch diameter local sewer line flowing north in S. Esplanade Ave at intersection with Avenue I	8,900	60	Year round from 10:00 p.m. to 6:00 a.m.
Los Angeles County DPW/ Los Angeles County Flood Control District (Herondo)	446 1/2 Herondo Hermosa Beach, CA 90254	Connect to: local sewer line running east-west in the north side of Herondo St	43,200	60 from 6:00 a.m. to 10:00 p.m. and 120 from 10 p.m. to 6:00 a.m.	Year round
Los Angeles County DPW (28th Street & The Strand)	2621 The Strand Manhattan Beach, CA 90266	Connect to: South Bay Cities Main Pumping Plant at 27 th St and The Strand	80,000	130	Year round from 8:00 p.m. to 6:00 a.m.
Los Angeles County DPW/ Flood Maintenance Division (Alamitos Bay)	222 Claremont Long Beach, CA 90803	Connect to: Anaheim Street Trunk Sewer (MH 03-0308)	20,000	60	Year round from 11:00 p.m. to 7:00 a.m.
Los Angeles County DPW/ Flood Maintenance Division (Apian Way Pump Station)	5871 Appian Long Beach, CA 90803	Connect to: Anaheim Street Trunk Sewer (MH 03-0308)	3,000	30	24 hrs per day year round
City of Long Beach DPW (Termino Avenue Drain)	Roswell Avenue (Between 7 th Street and 8 th Street) Long Beach, CA 90804	Connect to: Marina Relief Trunk, Section 1B (MH 03-0488)	23,000	100	Year round from 12:00 a.m. to 6:00 a.m.
City of Long Beach Parks, Recreation, and Marine Department (Colorado Lagoon)	W. 6 th St and Park Ave Long Beach, CA 90814	Connect to: Marina Relief Trunk, Section 1B (MH 03-0369)	80,000	300	Year round from 12:00 a.m. to 6:00 a.m.

GPD = gallons per day
GPM = gallons per minute
DPW = Department of Public Works
MH = manhole
hrs = hours

In addition, the Sanitation Districts' recently restored Bixby marshland, a 17-acre marsh area located on the JWPCP property, accepts DWUR and WWUR from the nearby Wilmington Drain. The marshland provides natural treatment to the water as it passes through. After flowing through the marshland, the DWUR and WWUR returns to the Wilmington Drain and eventually flows to the Los Angeles Harbor.

5.2.4.5 Planning Impacts

The impacts of the Sanitation Districts' policy for the acceptance of storm drain and urban runoff diversions are expected to be limited in terms of the future facilities' requirements and the present planning effort. Each of the main system components are reviewed as follows.

Conveyance System

The potential impacts to the conveyance system are minimal because the WWUR diversions are very limited (1/10 inch of rainwater), and the DWUR diversions are permitted only where sufficient hydraulic capacity exists within the system. DWUR diversions must be automatically suspended if rain occurs. With these provisions in place, there is no special consideration given in terms of current or future conveyance system sizing resulting from acceptance of these diversions.

Treatment Plants

Hydraulic considerations relative to treatment plants are addressed by the dry season, non-peak hour flows outlined for the conveyance system. The requirements for procurement of a permit and the provisions in place for pretreatment, testing, and monitoring of the diversion flow's composition control the amount of undesirable constituents entering the treatment plants. As such, there are no special considerations given to the sizing of, or processes provided for, the JOS treatment plants resulting from the inclusion of these diversions.

5.3 Water Reclamation Plants

The JOS WRPs are located upstream of the JWPCP and, with the exception of the LACAWRP, treat wastewater to a tertiary level. Recycled water produced at the WRPs may be beneficially reused or discharged to the San Gabriel and Rio Hondo tributaries that eventually flow to the Pacific Ocean. Five of the six WRPs (POWRP, SJCWRP, WNWRP, LCWRP, and LBWRP) discharge some or all of their treated effluent to the San Gabriel River watershed. The effluent from the LACAWRP is entirely reused at an adjacent country club.

The WRPs provide two principle benefits to the JOS. First, these plants make recycled water available to the locations where reuse demands are the greatest with minimal need for distribution systems and pumping. Second, the upstream locations of the WRPs provide hydraulic relief for the downstream wastewater conveyance system, which reduces the capital costs associated with constructing new relief sewers.

The WRPs have a number of unique operating features. The plants meet all water reclamation requirements (WRRs) and produce effluent that is suitable for beneficial reuse. Because they are part of the larger JOS, the WRPs have no solids handling capabilities; instead, all waste solids are discharged back to the JOS conveyance system for treatment at the JWPCP.

Production of effluent suitable for reuse requires multi-stage treatment. Except for the LACAWRP, the WRPs use primary sedimentation, nitrification-denitrification (NDN) reactors with secondary sedimentation, and effluent filtration. The main process differentiator between the individual WRPs is the

use of either the Step-Feed Anoxic (SFA) or the Modified Ludzack-Ettinger (MLE) reactor configurations for NDN. The two process types achieve the same effluent quality but with differing tank configuration, feed points, and internal recycle use. With the exception of the WNWRP, the WRPs provide disinfection utilizing hypochlorite and dechlorination with sodium bisulfite. The WNWRP primarily utilizes ultraviolet (UV) irradiation for disinfection, with hypochlorite disinfection and sodium bisulfite dechlorination as a backup. Each WRP is discussed in the following subsections. Flows cited represent the treated average daily flow for the year 2010.

5.3.1 Pomona Water Reclamation Plant

The POWRP is located at 295 Humane Way on a 14-acre site within the limits of the city of Pomona. The POWRP is bound by a railroad right of way to the north, the Humane Society to the south, Humane Way to the east, and Elephant Hill to the west. The surrounding land use is composed of industrial and commercial zones. Residential areas may be found further to the north of the railroad and further south of the Humane Society. An aerial view of the POWRP is shown on Figure 5-3.

The POWRP, originally known as the Tri-City Plant, was owned by the cities of Pomona, Claremont, and La Verne and placed into operation in 1926. Effluent reuse began in 1927. The Sanitation Districts took over operation of the POWRP in 1966 and completed Stage I of the existing configuration. Conversion of the original activated sludge system to an MLE process to achieve NDN was completed in 2004.

The permitted capacity of the POWRP is 15.0 million gallons per day (MGD). In 2010, the plant treated an average daily flow of 9.1 MGD, and 7.6 MGD of the effluent was beneficially reused at 192 individual sites. Reuse applications include irrigation and dust control at the Spadra Landfill and industrial use. The remainder of the effluent is discharged into the south fork of the San Jose Creek channel where it makes its way to the unlined portion of the San Gabriel River, a designated water of the United States (U.S.). Effluent that percolates into the groundwater at this location is monitored by the Water Replenishment District (WRD).

Primary solids, scum, and waste activated sludge generated by the POWRP are returned to the District 21 Interceptor for conveyance to the JWPCP for processing.

5.3.2 San Jose Creek Water Reclamation Plant

The SJCWRP is located at 1965 Workman Mill Road on a 51-acre site within unincorporated Los Angeles County, next to the city of Whittier. The SJCWRP is split by Interstate (I-) 605 into two independent, but hydraulically interconnected, plants. The east plant (SJCWRP East) discharges to both the San Gabriel River and San Jose Creek (a tributary of the San Gabriel River), while the west plant (SJCWRP West) discharges only to the San Gabriel River. The overall site is bound by San Jose Creek to the north, State Route (SR-) 60 to the south, Workman Mill Road to the east, and the San Gabriel River to the west. Easements owned by the city of Los Angeles, the Los Angeles Department of Water and Power, and the state of California run along the northern side of the property. Land uses surrounding the plant consist mostly of low-density residential areas, intermixed with an industrial area to the west and open recreational space to the east. An aerial view of the SJCWRP is shown on Figure 5-4.

The SJCWRP started operation in 1971. The combined permitted capacity of the SJCWRP is 100.0 MGD (62.5 at SJCWRP East and 37.5 at SJCWRP West). The activated sludge process was converted from a conventional step-feed nitrification process to an SFA NDN process in 2004.



FIGURE 5-3

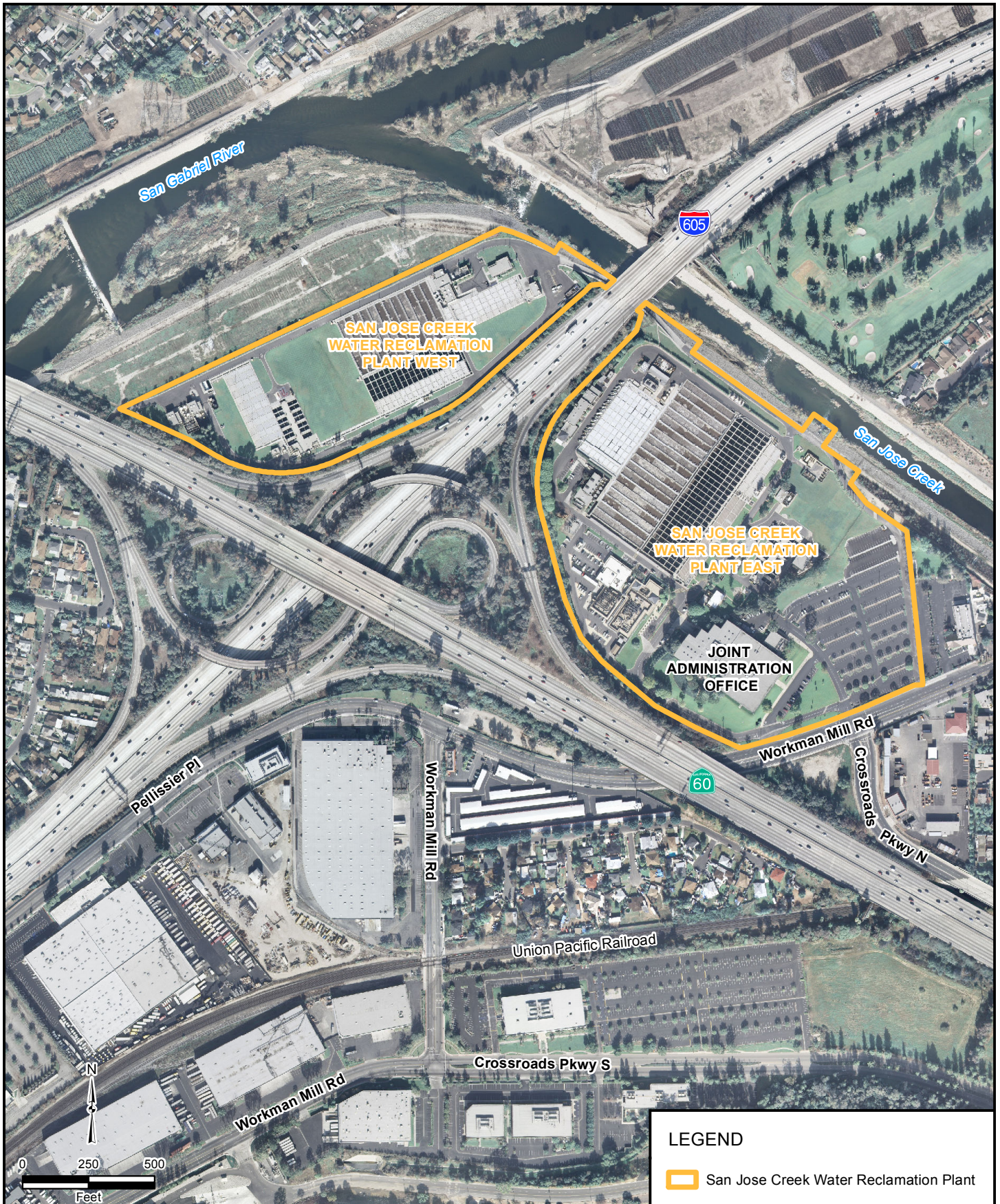

FIGURE 5-4

In 2010, the plants treated a combined average daily flow of 77.0 MGD, and 41.6 MGD of tertiary effluent was reused at 84 individual sites. Groundwater recharge remains the largest beneficial use of the effluent. Approximately 37 MGD of effluent was used by the WRD for groundwater recharge. Groundwater recharge is accomplished by sending effluent to the San Gabriel Coastal Spreading Grounds, the Rio Hondo Spreading Grounds, San Jose Creek, or the San Gabriel River. The remaining effluent is discharged to the lined portion of the San Gabriel River approximately 8 miles south of the SJCWRP.

Primary solids, scum, and waste activated sludge generated by the SJCWRP are returned to the Joint Outfall H trunk sewer for conveyance to the JWPCP for processing.

5.3.3 Whittier Narrows Water Reclamation Plant

The WNWRP is located at 301 N. Rosemead Boulevard near the city of South El Monte on a 27-acre site that the Sanitation Districts lease from the U.S. Army Corps of Engineers. The WNWRP surroundings are dominated by the Whittier Narrows Recreation Area to the north, undeveloped industrial areas to the south, Legg Lake and nurseries to the east, and a largely unused utility area to the west. The Rio Hondo cuts through the northwest corner of the site. Compared to the other WRPs, the site is relatively undeveloped. An aerial view of the WNWRP is shown on Figure 5-5.

The WNWRP was the first reclamation plant built by the Sanitation Districts for the purpose of demonstrating the feasibility of large-scale water reclamation. The original plant was placed in operation 1962 and consisted of primary and secondary treatment with conventional activated sludge. The activated sludge process was converted to a MLE process to achieve NDN in 1998.

The permitted capacity of the WNWRP is 15.0 MGD. In 2010, the WNWRP treated an average daily flow of 7.1 MGD, and 7.0 MGD of the effluent produced at the plant was used for groundwater recharge and irrigation at three individual sites. Treated effluent is discharged to the Rio Hondo, the Zone 1 Ditch, or the San Gabriel River. Effluent discharged to the Rio Hondo and Zone 1 Ditch flows south to the Rio Hondo Spreading Grounds, and effluent discharged to the San Gabriel River flows south to the San Gabriel Coastal Spreading Grounds.

Primary solids, scum, and waste activated sludge generated by the WNWRP are returned to the Joint Outfall B trunk sewer for conveyance to the JWPCP for processing.

5.3.4 Los Coyotes Water Reclamation Plant

The LCWRP is located at 16515 Piuma Avenue on a 34-acre site within the city of Cerritos. The treatment facilities occupy the lower southwest corner of the site. The remaining 20 acres are leased to the city of Cerritos for use as the Iron-Wood Nine Golf Course. The LCWRP is bound by Southern California Edison property to the north, SR-91 to the south, I-605 to the east, and the San Gabriel River to the west. Land uses surrounding the LCWRP consist of light industrial areas to the north and south, and residential areas to the east and west. Caruthers Park is located immediately west of the LCWRP. An aerial view of the LCWRP is shown on Figure 5-6.

The LCWRP was commissioned in 1970 with an initial capacity of 12.5 MGD. The LCWRP originally consisted of primary and secondary treatment with conventional activated sludge. The activated sludge process was converted to an SFA NDN process in 2008.



FIGURE 5-5



FIGURE 5-6

Los Coyotes Water Reclamation Plant

The current permitted capacity of the LCWRP is 37.5 MGD. In 2010, the plant treated an average daily flow of 26.8 MGD, and 5.1 MGD of the effluent produced at the plant was beneficially reused at 273 individual sites. Beneficial reuse applications include landscape irrigation of schools, golf courses, parks, nurseries, and greenbelts, and industrial applications at local companies for carpet dyeing and concrete mixing. The Central Basin Municipal Water District is the largest beneficial user, followed by the cities of Cerritos, Lakewood, and Bellflower. The majority of effluent is discharged to the lined portion of the San Gabriel River that flows directly to the Pacific Ocean.

Primary solids, scum, and waste activated sludge generated by the LCWRP are returned to the Joint Outfall F trunk sewer and conveyed to the JWPCP for processing.

5.3.5 Long Beach Water Reclamation Plant

The LBWRP is located at 7400 E. Willow Street on a 17-acre site within the city of Long Beach. Facilities are distributed evenly throughout the site with pockets of undeveloped areas. The LBWRP is bound by Willow Street to the north, Coyote Creek to the south and east, and the San Gabriel River to the west. El Dorado Park to the north and the El Dorado Municipal Golf Course to the west dominate the surrounding land. Residential areas may be found to the south and east of the LBWRP. An aerial view of the LBWRP is shown on Figure 5-7.

The LBWRP was commissioned in 1973. The activated sludge process was converted to an SFA NDN process in early 2008.

Immediately north of the LBWRP is the Leo J. Vander Lans Advanced Water Treatment Facility (AWTF), a state-of-the-art facility owned by WRD with a design capacity of 3 MGD (product water). The Leo J. Vander Lans AWTF supplies water to protect the Central Groundwater Basin from seawater intrusion. The high quality water is blended with imported water and pumped into the Alamitos Seawater Barrier, one of three seawater barrier systems within the WRD service area. The AWTF receives effluent from the LBWRP and provides further treatment via microfiltration, reverse osmosis, and ultraviolet disinfection.

The permitted capacity of the LBWRP is 25.0 MGD. In 2010, the plant treated an average daily flow of 18.4 MGD, and 5.7 MGD of the effluent produced at the plant was beneficially reused at 56 individual sites. The city of Long Beach used approximately 3.8 MGD of recycled water for landscape irrigation of schools, golf courses, parks, and greenbelts. The WRD used approximately 2.0 MGD of recycled water at the Leo J. Vander Lans AWTF. The majority of the effluent is discharged to the lined portion of Coyote Creek, which then joins the San Gabriel River and flows to the Pacific Ocean.

Primary solids, scum, and waste activated sludge generated by the plant and brine generated by Leo J. Vander Lans AWTF are returned to the Joint Outfall C trunk sewer and conveyed to the JWPCP for processing.

5.3.6 La Cañada Water Reclamation Plant

The LACAWRP is located at 533 Meadowview Drive on approximately 0.3 acre on the grounds of the La Cañada Flintridge Country Club golf course. An aerial view of the LACAWRP is shown on Figure 5-8.

The LACAWRP began operation in 1962 and provides extended aeration treatment. The plant has a permitted capacity of 0.2 MGD. In 2010, the LACAWRP treated an average daily flow of 0.1 MGD.

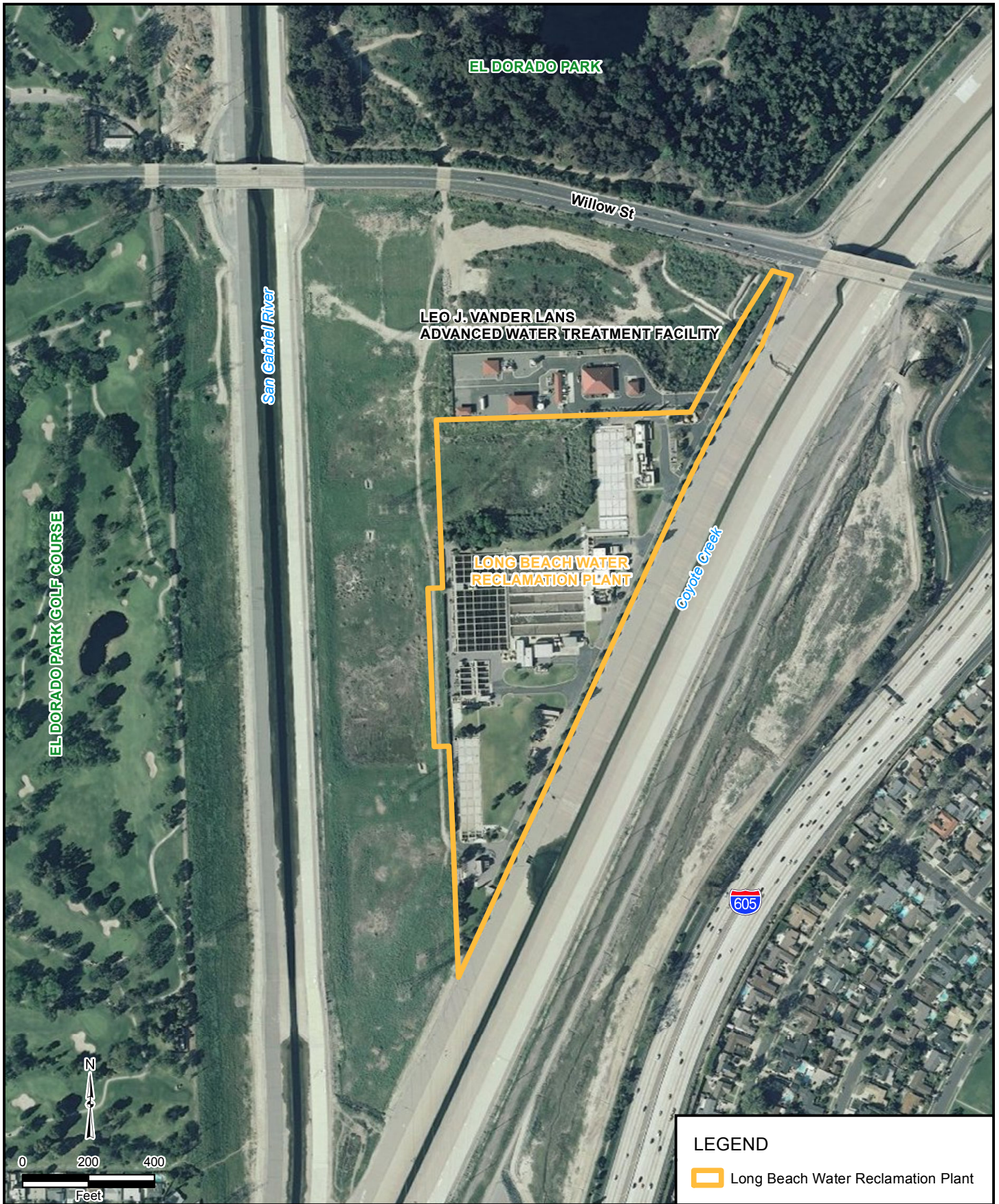

FIGURE 5-7



FIGURE 5-8

The LCAWRP serves the golf course and 425 surrounding homes. All of the disinfected, secondary effluent flows into irrigation system storage impoundments on the 105-acre golf course.

5.3.7 Water Reclamation Plant Process Capabilities

This section reviews the process capabilities of the WRPs. Specific information is provided for each plant in terms of:

- Process schematics
- Design criteria
- WRP capacities
- Future planning considerations

The LCAWRP is not included within these discussions because as the facility's capacity is very small (0.1 MGD) relative to the other WRPs. In addition, it does not have discharge to surface waters and, therefore, has different treatment requirements.

5.3.7.1 Process Schematics

The Sanitation Districts' WRPs share a generalized process schematic, as depicted on Figure 5-9. Some minor features are specific to particular treatment plants. For example, the POWRP does not have influent pumps or process air compressors that draw foul air from the headspace of the covered primary sedimentation tanks. The two nitrogen removal processes employed at the WRPs are the MLE process (Figure 5-10) at the WNWRP and POWRP, and an SFA process (Figure 5-11) at the SJCWRP, LCWRP, and LBWRP.

5.3.7.2 Water Reclamation Plant Design Criteria

The design criteria for each of the plants are summarized in Table 5-4. These criteria reflect the nitrogen removal process modifications. Also, since the SJCWRP includes two physically separate facilities, design criteria are provided for each.

Table 5-4. Water Reclamation Plant Design Criteria

Design Element	Unit	POWRP	SJCWRP East	SJCWRP West	WNWRP	LCWRP	LBWRP
Plant Flows							
Average	MGD	15	62.5	37.5	15	37.5	25
Peak Sanitary	MGD	20	90	60	20	60	34
Peak Storm	MGD	30	125	75	25	75	60
Equalized Waste Filter Backwash	MGD	0.9	1.6	-	-	-	-
Primary Sedimentation Tanks							
Number	-	3	8	5	2	4	4
Dimensions (LxWxD)	feet	100x20x10	300x20x12	300x20x12	300x20x12	300x20x12	300x20x12
Avg Overflow Rate	gpd/ft ²	2,200	1,300	1,300	1,250	1,560	1,042
Avg Detention Time	hours	0.85	1.65	1.65	1.70	1.38	2.07
Avg SS Removal	%	66	65	62	61	60	67
Avg BOD ₅ Removal	%	45	35	36	35	35	37

Table 5-4 (Continued)

Design Element	Unit	POWRP	SJCWRP East	SJCWRP West	WNWRP	LCWRP	LBWRP
Aeration Tanks							
Process Configuration	-	MLE	SFA	SFA	MLE	SFA	SFA
Number	-	3	20	12	3	12	8
Dimensions (LxWxD)	feet	260x30x15	225x30x15	225x30x15	300x30x15	225x30x15	225x30x15
Fraction Anoxic	%	22-33	25	25	22-33	25	25
Fraction Aerobic	%	67-78	75	75	67-78	75	75
Equipment Type	-	Fine Bubble	Fine Bubble	Fine Bubble	Fine Bubble	Fine Bubble	Fine Bubble
Make	-	Sanitaire	Sanitaire	Sanitaire	Sanitaire	Sanitaire	Sanitaire, Grey
HRT Total	hours	2.58	1.86	1.86	2.24	1.86	1.86
Process Air Compressors							
Number	-	3	5	3	3	5	4
Type	-	Centrifugal	Centrifugal	Centrifugal	Centrifugal	Centrifugal	Centrifugal
Capacity (per Unit)	cfm	13,300	3@44,000 2@20,000	44,000	1@5,500 2@11,100	3@20,000 2@60,000	2@20,000 2@10,000
Final Sedimentation Tanks							
Number, Total	-	6	30	18	6	18	13
Number Assigned to BWR	-	1	-	-	1	-	1
Dimensions (LxWxD)	feet	150x18x10	150x20x10	150x20x10	150x20x10	150x20x10	150x20x10
Avg Overflow Rate	gpd/ft ²	960	694	694	1,000	694	694
Avg Detention Time	hours	1.11	1.94	1.94	1.35	1.94	1.94
Filters							
Number	-	8	20	14	6	12	10
Type	-	Gravity – Mono	Gravity – Dual	Gravity – Mono	Gravity – Dual	Gravity – Dual	Gravity – Dual
Dimensions (LxWxD media)	feet	32x16x6	37x16x7.6	37x16x7.2	32x16x12	37x16x7.5	32x16x7.7
Avg SLR (All in Service)	gpd/ft ²	2.54	3.63	3.11	3.39	3.63	3.40
Filter Effluent Pumps							
Number	-	3	5	3	3	4	4
Type	-	Vertical Mixed Flow	Vertical Mixed Flow	Vertical Mixed Flow	Vertical Mixed Flow	Vertical Mixed Flow	Vertical Wet Pit
Capacity per Pump	gpm	7,000	2@22,800 1@22,000 1@12,200 1@13,800	23,000	2@6,000 1@5,500	2@13,800 2@22,800	2@7,500 2@8,650
Filter Backwash Pumps							
Number	-	2	2	2	2	2	2
Type	-	Centrifugal	Vertical Mixed Flow	Vertical Mixed Flow	Vertical Turbine	Vertical Mixed Flow	Vertical Wet Pit
Capacity per Pump	gpm	10,000	6,500	13,500	2,000	6,500	10,000
Filter Waste Backwash Recovery Tank							
Number	-	1	1	1	1	1	2
Volume (Effective)	gallons	200,000	136,925	135,000	224,000	137,000	224,000

Table 5-4 (Continued)

Design Element	Unit	POWRP	SJCWRP East	SJCWRP West	WNWRP	LCWRP	LBWRP
Chlorine Contact Tanks							
Number	-	3	4 (Series)	4	2 ^a	2	3
Dimensions (LxWxD)	feet	185x20x16	386x13x16	300x27x15	655x8.2x15	800x22x13	287.5x20x20

^a The existing chlorine contact tanks have been retrofitted for UV irradiation. The UV equipment is located within a portion of the tanks, which provides for use of the tanks as a backup disinfection process and for recycled water storage.

MGD = million gallons per day
 Avg = average
 gpd = gallons per day
 gpm = gallons per minute
 ft² = square feet
 cfm = cubic feet per minute
 MLE = modified Ludzack-Ettinger
 SFA = step-feed anoxic
 SS = suspended solids
 COD = chemical oxygen demand
 BOD₅ = biochemical (or biological) oxygen demand
 HRT = hydraulic retention time
 BWR = backwash recovery
 SLR = surface loading rate

5.3.7.3 Water Reclamation Plant Capacities

Treatment plant capacity was assessed in terms of:

- Permitted capacities
- Ultimate site capacities

Each of these is briefly reviewed in the following sections.

Permitted Capacities

In addition to the discharge requirements provided in terms of concentrations for various constituents, each of the WRPs has a permitted maximum flow capacity. This capacity cannot be exceeded without a change to the facility's NPDES permit. Treated flows for individual plants are monitored relative to the permitted capacity. As the flow approaches the permit capacity, the Sanitation Districts are required to submit reports to the regulatory authorities outlining their plans to accommodate additional flows. In the past, the most recent facilities plan documents have served this purpose.

Ultimate Site Capacities

Each WRP has a defined site property boundary. The site boundary limits the available area for future facilities and determines the ultimate capacity of the site. Ultimate site capacities for each WRP were determined by the Sanitation Districts as part of the JOS 2010 Master Facilities Plan (2010 Plan). These capacities were based on conventional activated sludge processes. None of the property boundaries have changed since that time and conventional activated sludge processes are still assumed, so the ultimate site capacities have not changed.

There may be other factors, not strictly related to land area, that could affect the ultimate site capacity of the WRPs. For instance, to achieve the ultimate 80 MGD site capacity at the WNWRP, extensive site improvements for flood protection and permitting would be required. The 125 MGD ultimate capacity of

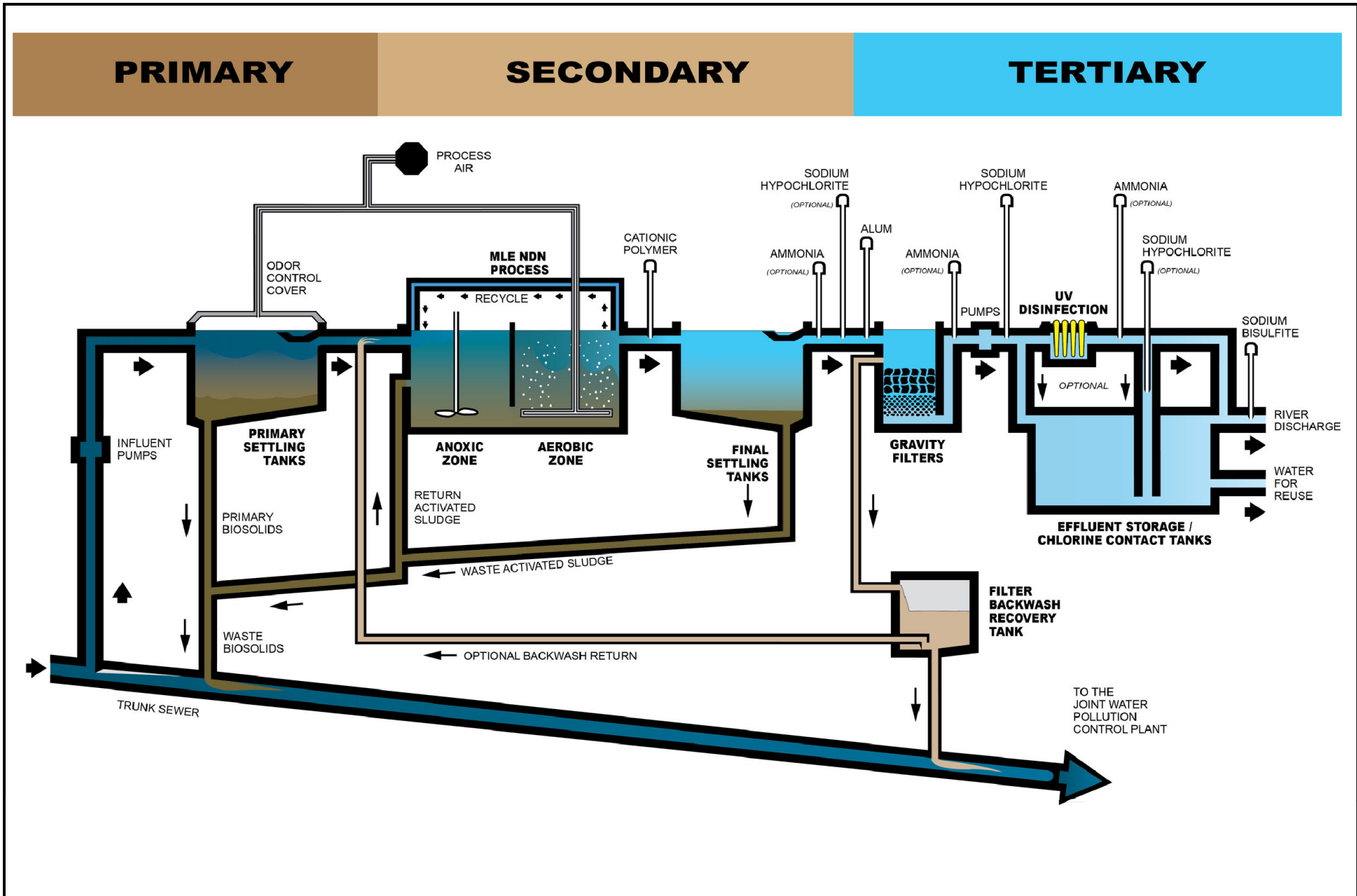

FIGURE 5-9

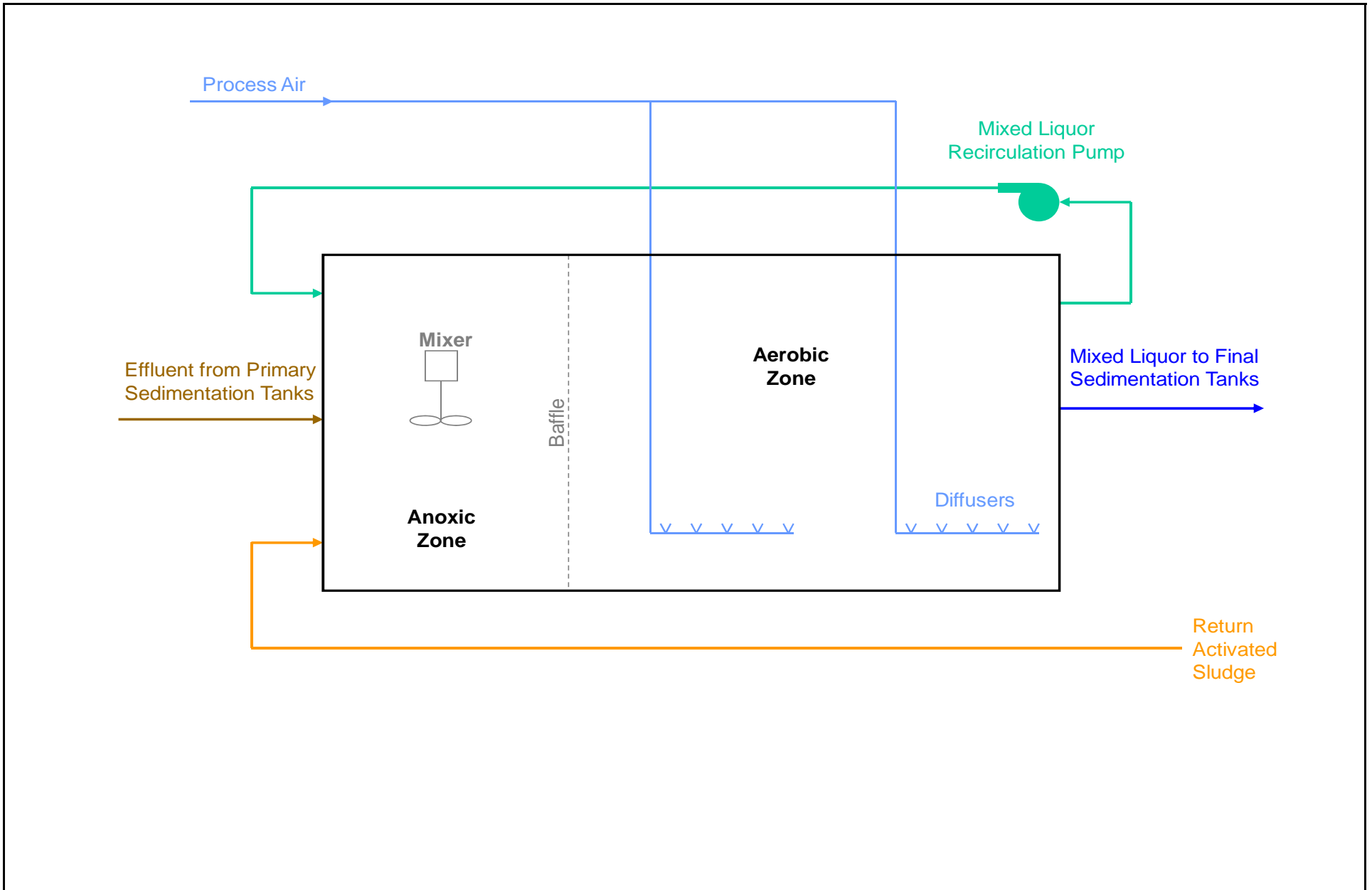

FIGURE 5-10

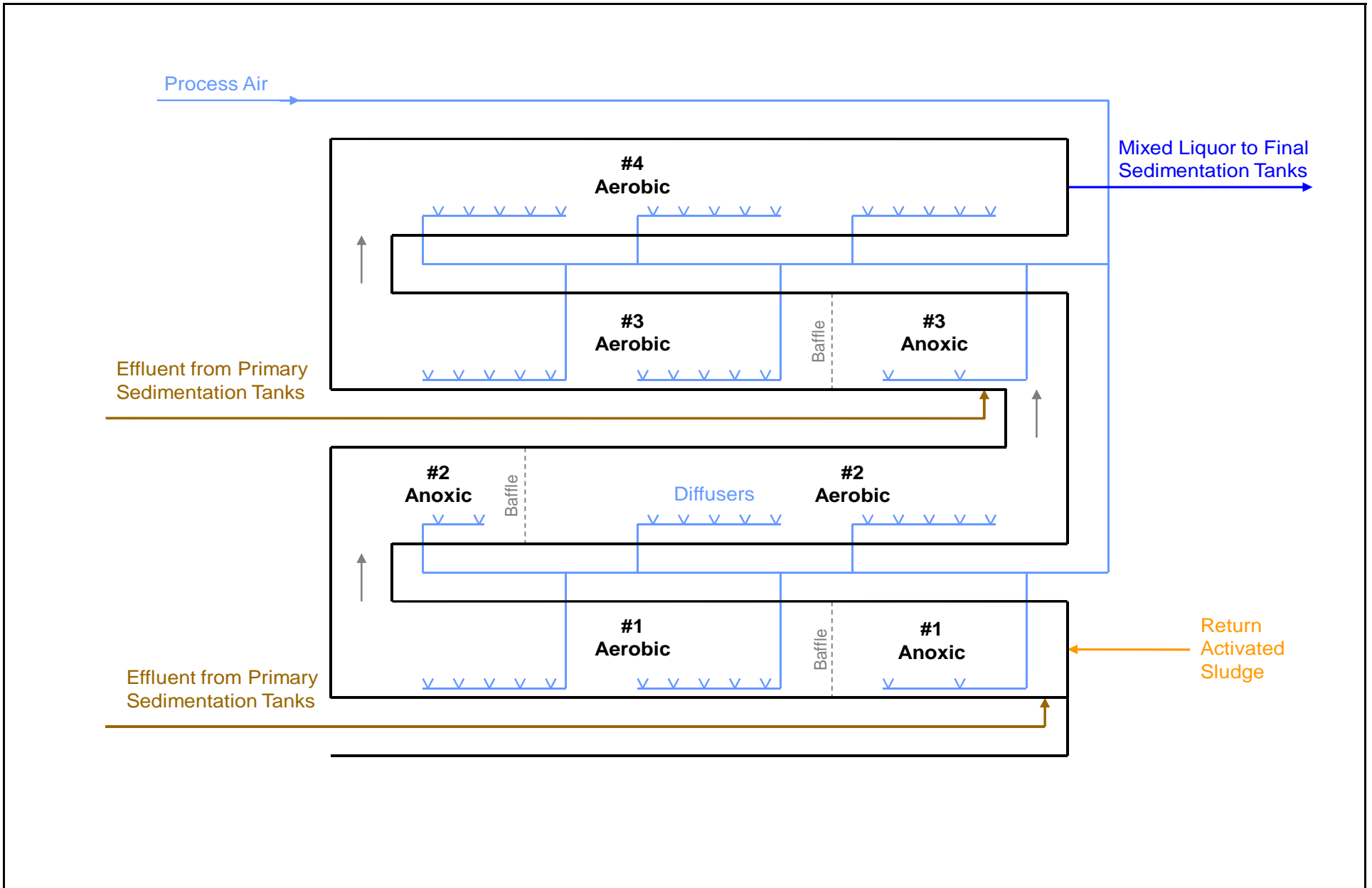

FIGURE 5-11

the LCWRP would require displacement of public recreational facilities that currently occupy the Sanitation Districts' property.

A summary of the permitted and ultimate site capacities for the WRPs is provided in Table 5-5.

Table 5-5. Water Reclamation Plant Permitted and Site Capacities

Water Reclamation Plant	Permitted Capacity (MGD)	Ultimate Site Capacity (MGD)
POWRP	15.0	30
SJCWRP	100.0	125
WNWRP	15.0	80
LCWRP	37.5	125
LBWRP	25.0	50

5.3.7.4 Planning Considerations

A plant's future treatment capabilities can be affected by a variety of factors such as current performance and future discharge requirements. Some of the considerations that affect current performance include nitrogen control improvements, ammonia removal and nitrogen limits, disinfection processes, and total dissolved solids (TDS). Each of these is briefly described in the following subsections.

Nitrogen Control Improvements

In response to more stringent discharge limits, the Sanitation Districts undertook a program to retrofit the existing JOS WRPs so that these facilities would consistently meet ammonia and total inorganic nitrogen objectives. The assessment of alternative approaches and the recommended plan was the subject of the Joint Outfall System Nitrification/Denitrification Facilities Plan, dated December 2001. The recommended plan involved the conversion of the plants' conventional activated sludge processes to multi-staged NDN systems. Five of the WRPs were converted to NDN between 1998 and 2008, and all currently operate in this mode.

Conversions to NDN systems have the potential to affect a WRP's treatment capacity in several ways. First, a portion of the reactor tankage is retrofitted from operating in an aerobic mode to an anoxic mode. This effectively decreases the detention time available for the aerobic reaction. In addition, the NDN process typically runs at a higher mixed liquor concentration. Higher mixed liquors result in higher solids loading to the secondary clarifiers, and can thereby affect the capacity of these systems. Systems operated with higher mixed liquor concentrations may also produce a sludge that does not compact or settle as readily when compared to solids produced in a process operating with a lower mixed liquor concentration. Overall, conversions to NDN systems can make WRPs more sensitive to peak hydraulic flows and nutrient loadings. Therefore, as flows approach the permitted capacities of the WRPs, it may be necessary to implement process optimization measures, such as the addition of flow equalization, to ensure that the Sanitation Districts continue to consistently meet permit conditions in anticipation of increasingly stringent regulatory requirements.

Ammonia Removal and Nitrogen Limits

Ammonia is a key parameter for assessing the WRPs' treatment capabilities. Reasons include:

- For nitrogen removal, nearly complete nitrification is necessary to allow for the anoxic denitrification processes to reduce the nitrates and nitrites to the required levels

- Ammonia levels are regulated in the effluents of each WRP and could be subject to more stringent limits in the future
- Ammonia concentrations within the treatment train impact the current disinfection process performance

As a result, influent ammonia concentrations and loading, coupled with effluent limitations for ammonia, total nitrogen, and disinfection byproducts can affect WRPs' treatment capacities.

Disinfection Processes

The disinfection process is a critical element for ensuring the public's health and safety relative to effluent discharges and beneficial reuse applications. Disinfection can affect a facility's treatment capabilities in terms of measures required to control byproduct formation, as well as achieving prescribed minimum requirements for disinfectant concentration and contact time.

Byproduct Formation. Chlorination using sodium hypochlorite or chlorine is used for disinfection at the WRPs. In the presence of ammonia, chloramines are formed and the resulting disinfection is referred to as chloramination. The Sanitation Districts have used chloramination at the WRPs to limit the production of trihalomethanes (THMs) to effluent concentrations of less than 20 micrograms per liter ($\mu\text{g/L}$), which is 4 times lower than the California drinking water standard (Tang, et al., CWEA Wastewater Professional, V 42, n 3, July 2006). To achieve this, ammonia has been added to the secondary effluent as necessary to provide 1 to 2 milligrams per liter (mg/L) ammonia at the point of hypochlorite addition, ahead of the tertiary filtration process. Reliable control of this process is best achieved with low secondary effluent ammonia concentrations.

While chloramination is effective in controlling the possible production of THMs, the process is also a potential source of N-nitrosodimethylamine (NDMA) formation. As NDMA is a constituent of concern, it is beneficial to reduce its potential formation by modifications to the disinfection process. As a result, the Sanitation Districts have evaluated the alternative disinfection strategies of UV irradiation and sequential chlorination. The latter is a modification of the chloramination process where low ammonia concentrations are maintained ahead of the initial hypochlorite addition point for free chlorination at the filters as a first step. The second step adds additional hypochlorite at the chlorine contact tank in the presence of a low, but controlled, ammonia concentration, with ammonia added as required, to complete the disinfection process by chloramination.

Low and consistent secondary effluent ammonia concentrations are important for process stability and reliable disinfection performance when employing either method of chlorination.

Application of UV. The Sanitation Districts have implemented UV irradiation at the WNWRP and are conducting full-scale evaluations of sequential chlorination. The UV system design concept developed for the WNWRP is based on the installation of the UV equipment within a portion of the existing chlorine contact tank (CCT). This approach requires no additional space at the site, provides for continued use of the remaining CCT as a backup disinfection process for peak flow or maintenance conditions, and provides for recycled water storage.

Chlorine Residual/Contact Time (CT) Requirements and Capacity. The California Title 22 regulations for reuse are specific regarding chlorination and require a minimum value for contact time multiplied by the residual chlorine concentration (CT value) of 450 $\text{mg}\cdot\text{min/L}$ with a minimum modal contact time of 90 minutes. Alternatively, and in accordance with the Title 22 regulations, a lower CT

value can be used if it is demonstrated that the combined filtration and disinfection process provides equivalent treatment.

Total Dissolved Solids

The presence of TDS in WRP effluent can limit potential reuse applications. Recently, the Sanitation Districts have evaluated the potential impacts of future regulations on TDS and, in particular, chloride concentration. It was concluded that microfiltration followed by reverse osmosis (MF/RO) presents a viable and proven process to reduce TDS and chloride concentrations, but at considerable expense. The MF/RO process would produce a highly purified product water and a brine side stream that would be conveyed to the JWPCP for ocean disposal. The Sanitation Districts are committed to working with the community using the recycled water produced at the WRPs to achieve cost-effective upgrades to treatment, as required, and support expanded reuse of this important resource. This would be accomplished within a framework that maintains consistency with regional salinity management plans.

5.4 Water Reclamation Plant Effluent Management

All treated effluent generated at the upstream WRPs within the JOS is managed in one of two ways:

- Discharge to a surface water
- Beneficial reuse

5.4.1 Surface Water Discharge

All of the WRPs, with the exception of the LACAWRP, include some form of surface water discharge as part of their effluent management systems. Recycled water is discharged to the San Gabriel River or one of its tributaries. In cases where the discharge is to an unlined channel or reach of the river, some level of groundwater recharge can be expected to take place in connection with the surface water discharge. In a number of cases, the surface water discharge serves as a means to convey the effluent to a downstream reuse application, such as groundwater recharge or irrigation.

5.4.1.1 Pomona Water Reclamation Plant

The POWRP discharges into San Jose Creek, which ultimately flows into the San Gabriel River. Portions of San Jose Creek, where this discharge takes place, and the section of the San Gabriel River into which San Jose Creek flows, are unlined. Almost all of the surface discharge from the POWRP results in incidental groundwater recharge.

5.4.1.2 San Jose Creek Water Reclamation Plant

The SJCWRP consists of two completely separate, independently operated plants: SJCWRP East and SJCWRP West. Between the two plants there are four discharge points. They are:

- SJC 001: This outfall can convey effluent from both the SJCWRP East and the SJCWRP West. Flow from this outfall discharges into a lined portion of the San Gabriel River approximately 8 miles south of the plant. Along the 8-mile stretch, the outfall line is tapped at a number of locations to provide recycled water for different reuse applications.
- SJC 001A: Approximately 3 miles downstream of the plant, along the outfall to SJC 001, there is a turnout that allows effluent to be conveyed to an unlined portion of the San Gabriel River. This allows for incidental percolation of recycled water to the groundwater.

- SJC 002: The SJCWRP East discharges effluent at this point to a portion of San Jose Creek that is unlined and then flows into the San Gabriel River. Effluent is allowed to recharge groundwater and is conveyed via various channels and diversion structures to either the Rio Hondo Spreading Grounds or the San Gabriel Coastal Spreading Grounds.
- SJC 003: The SJCWRP West discharges effluent from this point to the unlined San Gabriel River. Effluent is used to recharge groundwater and is conveyed via various channels and diversion structures to either the Rio Hondo Spreading Grounds or the San Gabriel Coastal Spreading Grounds.

5.4.1.3 Whittier Narrows Water Reclamation Plant

The WNWRP has four permitted discharge points, but only three are currently in use. The fourth discharge point is a groundwater test basin that was last used for research in 1981. The four discharge points are:

- WN 001: Discharges to the San Gabriel River and flows to San Gabriel Coastal Spreading Grounds
- WN 002: Discharges to the Zone 1 Ditch, which flows to the Rio Hondo and the Rio Hondo Spreading Grounds
- WN 003: Test Basin (not in use)
- WN 004: Discharges to the Rio Hondo and flows to the Rio Hondo Spreading Grounds

5.4.1.4 Los Coyotes Water Reclamation Plant

The LCWRP discharges tertiary-treated effluent into the concrete-lined portion San Gabriel River, which flows to the Pacific Ocean.

5.4.1.5 Long Beach Water Reclamation Plant

The LBWRP discharges tertiary-treated effluent into the concrete-lined portion of Coyote Creek, about 2,200 feet upstream from the confluence with the San Gabriel River. The San Gabriel River is also lined from the Coyote Creek confluence to the Pacific Ocean.

5.4.2 Reclamation and Reuse

Reuse is an integral component of the WRPs' effluent management systems. In 2010, the Sanitation Districts provided recycled water to 29 water wholesalers and purveyors for distribution and use. These wholesalers and purveyors make the recycled water available to over 600 individual sites in 30 cities for multiple applications that include irrigation, industrial use, agriculture, and groundwater recharge. Over 50 percent of the WRP effluent is beneficially reused. A discussion of beneficial reuse is presented in Chapter 4.

5.5 Joint Water Pollution Control Plant

The JWPCP has been in service longer than any other of the Sanitation Districts wastewater treatment plants and is its largest facility. It is also one of the largest such plants in the world. The JWPCP is

located downstream of the WRPs and receives all JOS flows not treated by the WRPs. In addition to these flows, all solids generated by wastewater treatment within the JOS are processed at the JWPCP.

5.5.1 Plant Description

The JWPCP is located at 24501 South Figueroa Street in the city of Carson. The JWPCP occupies approximately 420 acres, of which approximately 200 acres are used as a buffer area between the operational process areas and the surrounding residential neighbors. The buffer areas, some of which extend into the city of Los Angeles, include the Wilmington Boys and Girls Club, the Wilmington Athletic Complex, the Bixby Marshland, the Carson Depot Commercial Center, and landscaping and nursery areas. Most of the JWPCP's facilities are in an area bound by I-110 to the west, Main Street to the east, Sepulveda Boulevard to the north, and Lomita Boulevard to the south. The plant provides a secondary level of treatment and disinfection. All of the JWPCP effluent is discharged to the Pacific Ocean. An aerial view of the JWPCP is shown on Figure 5-12.

The JWPCP has a permitted capacity of 400 MGD. Influent flows to the JWPCP are initially screened to remove large debris and protect downstream equipment. After screening, the flow passes through grit chambers for the removal of heavy, inorganic materials to avoid accumulation in process tankage. Flows are then directed to primary sedimentation tanks where readily settleable solids are removed and floating materials are skimmed from the surface. The activated sludge process, which receives the primary treatment effluent, is used for secondary treatment to remove a large portion of the organic materials and much of the remaining solids. The JWPCP uses high purity oxygen in the aeration basins (biological reactors). Following these reactors, final sedimentation tanks separate the activated sludge solids from the mixed liquor. These solids are either recycled back to the activated sludge process or diverted for further treatment and processing. The effluent from the secondary treatment process is disinfected using sodium hypochlorite prior to ocean discharge.

The systems for effluent management, solids processing, and solids management at the JWPCP are discussed separately in Sections 5.6, 5.7, and 5.8, respectively.

5.5.2 Process Capabilities

This section reviews the JWPCP's process capabilities and provides:

- Process schematics
- Design criteria
- Site capacity
- Planning considerations

The plant's liquid process flow was described in Section 5.5.1. A process flow schematic for the entire plant is shown on Figure 5-13. Design criteria for the liquid process stream are provided in Table 5-6. Representative influent characteristics are also provided in this table.



FIGURE 5-12

Joint Water Pollution Control Plant

JOINT WATER POLLUTION CONTROL PLANT

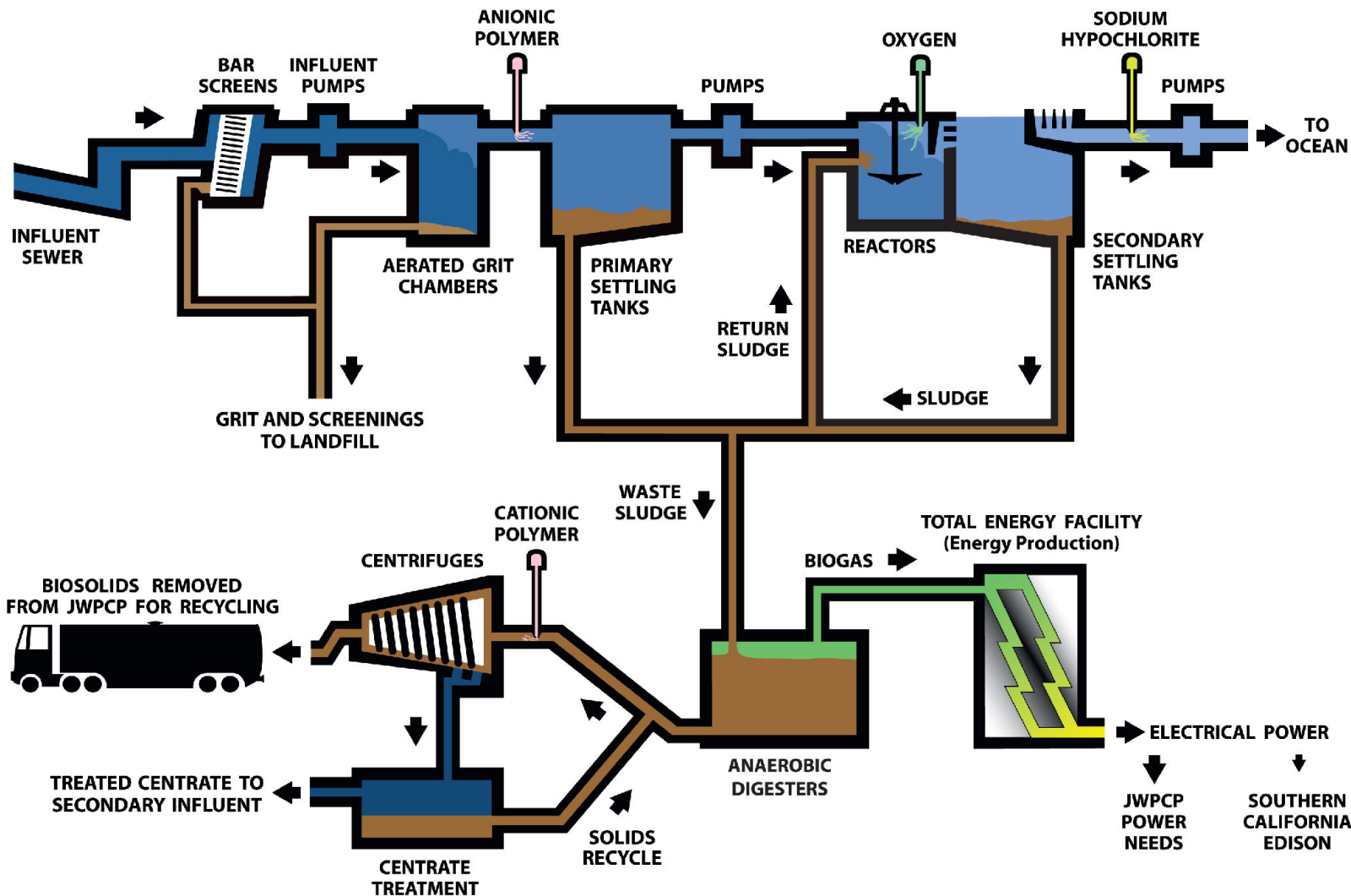

FIGURE 5-13

Table 5-6. Joint Water Pollution Control Plant Process Design Criteria Summary

Area	Criteria	Unit	Value
Influent Characteristics			
Plant Flows			
	Design Average Daily Flow	MGD	400
	Design Peak Sanitary	MGD	540
	Design Peak Storm	MGD	625
Influent Characteristics			
Design			
	Suspended Solids	mg/L	530
	Suspended Solids	ppd	1,769,140
	Biochemical Oxygen Demand	mg/L	425
	Biochemical Oxygen Demand	ppd	1,418,650
Actual (Annual Average)			
	Suspended Solids	mg/L	510
	Suspended Solids	ppd	1,383,184
	Biochemical Oxygen Demand	mg/L	410
	Biochemical Oxygen Demand	ppd	1,111,971
Influent Hydraulics			
Number of Pumps			
	Capacity – JO A (5 Pumps)	MGD	180
	Capacity – JO D (4 Pumps)	MGD	200
	Total Pumped Capacity	MGD	380
	Total Gravity Sewer Capacity – JO B	MGD	265
Headworks			
Barscreens			
	Type	-	Vertical
	Bar Spacing	inch	1
	Number	-	9
Grit Chamber			
	Number	-	6
	Type	-	Rectangular
	Average Detention Time	minutes	5
Primary Treatment			
Primary Sedimentation Tanks (PST)			
	Number of Tanks	-	52
	Dimensions, Range (W x L x D)	feet	18-21 x 240-300 x 8.5-12
	Average Detention Time	hours	1.4
	Average Overflow Rate	gpd/ft ²	1,400
	Estimated Solids Removal	%	75
Secondary Treatment			
Secondary Influent Pump Station (SIPS)			
	Number of Pump	-	5
	Capacity of Pumps – Each	MGD	170
	Total Pumping Capacity	MGD	850
	Total Pumping Capacity (w/Standby)	MGD	680

Table 5-6 (Continued)

Area	Criteria	Unit	Value
Aeration Reactors			
	Number of Modules	-	4
	Capacity per Module	MGD	100
	Total Capacity	MGD	400
	Aeration Type	-	Surface Aerators
	Number of Aerator per Module	-	18
	Average Detention Time	hours	2.5
	Average Detention Time (w/Recycle)	hours	1.9
	Total Oxygen Required	lbs O ₂ /day	720,000
Oxygen Generation System			
	Number of Cryogenic Plants	-	3
	Oxygen Generation Capacity, Peak	tpd	625
Final Sedimentation Tanks (FST)			
	FSTs per Module	-	52
	Total FSTs	-	208
	Dimensions (W x L x D)	feet	21 x 167 x 14
	Average Detention Time (w/Recycle)	hours	3.5
	Average Overflow Rate	gpd/ft ²	550
Return Activated Sludge (RAS) Pumps			
	Number of Pumps	-	24
	Pump Capacity – Each	MGD	18.75
	Total RAS Capacity (Excluding Standbys)	MGD	300
Secondary Effluent Pump Station			
	Number of Pumps	-	5
	Pump Capacity – Each	MGD	170
	Total Capacity	MGD	850
	Total Pumping Capacity(w/Standby)	MGD	680
Disinfection System			
Chlorination System			
	Type	-	Sodium Hypochlorite
	Average Condition (Flow/Dosage)		
	Dosage	mg/L	10
	Usage	ppd	33,380
	Maximum Conditions		
	Dosage	mg/L	17
	Usage	ppd	99,306

MGD = million gallons per day

mg/L = milligrams per liter

lbs = pounds

O₂ = oxygen

ppd = pounds per day

gpd = gallons per day

ft² = square feet

tpd = tons per day

Investigations have been undertaken to assess the ultimate site capacity of the JWPCP. Several assumptions were factored into these evaluations, including:

- Future processes and associated design criteria are similar to existing systems
- Consideration has not been given to existing technologies for compact treatment systems (e.g., double-deck clarifiers, ballasted flocculation reactors) to enhance site capacity
- New, more compact treatment technologies that may be developed in the future are not considered
- Areas identified for non-process facilities generally remain as such
- Areas identified for process facilities are not reduced
- There are no new, space-significant processes needed at the site as might be required by more stringent regulations or effluent disposal requirements

Based on these assumptions, the ultimate site capacity of the JWPCP is estimated at 700 MGD.

Considerations that could affect the JWPCP's operations, as well as any future system expansion or upgrades, are:

- Odor control
- Effluent reclamation and reuse

The Sanitation Districts are committed to making every effort to eliminate the migration of fugitive odors from the treatment plant to the surrounding community. To that end, the Sanitation Districts have invested in substantial facilities to reduce air emissions and resulting odors from the JWPCP. It is anticipated that additional control measures would be continuously evaluated and those providing effective emissions reduction would be implemented.

Currently none of the effluent from the JWPCP is beneficially reused, as the tributary flow to this plant is too high in TDS. In the future, with potential reductions in existing water supplies, coupled with increasing population, demand for recycled water in the vicinity of the JWPCP may be identified. There are a number of options for producing suitable recycled water. One is to treat the secondary effluent to a higher degree. A second approach is to hydraulically isolate the influent wastewater flow from specific trunk sewers with the lowest industrial contribution and lowest salinity content and treat that flow in a separate treatment train. These approaches would be evaluated in the future if recycled water demand is identified.

5.6 JWPCP Effluent Management

All disinfected, secondary treated effluent generated at the JWPCP is discharged to the Pacific Ocean through a system of tunnels and ocean outfalls. The existing ocean discharge system is shown on Figure 5-14. Two parallel tunnels extend from the JWPCP approximately 6 miles to a manifold structure located on the shoreline at Royal Palms Beach on the Palos Verdes Peninsula near White Point. There are four ocean outfalls that can be fed from the manifold by adjusting valve settings. Under normal operating conditions, the two largest outfalls are used; the other two smaller outfalls provide emergency backup capacity. The ocean outfalls extend up to one and a half miles offshore at a depth of approximately 200 feet below sea level.



FIGURE 5-14

**Joint Water Pollution Control Plant
Existing Ocean Discharge System**



Source: Sanitation Districts of Los Angeles County 2011, Thomas Bros 2011, ESRI 2011

The tunnel and ocean outfall system were constructed as a series of projects between 1934 and 1967. Neither of the tunnels has been inspected in nearly 50 years. Inspection of the tunnels is not possible due to their overall length, limited access, lack of hydraulic separation between the two, and continuous effluent flows. Repair and rehabilitation of these tunnels, should it be warranted, is not currently possible for the same reasons.

The ocean outfalls are more accessible for inspection, repair, and rehabilitation because they are located on the seafloor. Visual inspections are routinely performed using divers and remote operated vehicles. It has been determined that the smallest and oldest of the four outfalls has nearly reached the end of its useful life, so it cannot be relied upon to manage future flows. As part of this study, a total of 27 cast iron and 9 concrete core samples were taken from various locations on each of the three remaining outfalls. The samples underwent laboratory analysis and it was determined that these three outfalls are in good condition and, with minor re-ballasting and possible joint repairs, have a remaining useful life that will extend well beyond the 2050 planning horizon.

The primary components of the JWPCP ocean discharge system are described in Table 5-7.

Table 5-7. JWPCP Ocean Discharge System

Segment	Year Placed in Operation	Operational Status	Total Length (feet)	Material	Diffuser Length (feet)	Discharge Depth (feet)
8-foot Tunnel	1937	Operational	32,340	Reinforced Concrete	NA	NA
12-foot Tunnel	1958	Operational	32,340	Reinforced Concrete	NA	NA
60-inch Outfall	1937	Standby, only used during peak storm flows	4,900	RCP w/ CI Joints	400	110
72-inch Outfall	1947	Standby, only used during peak storm flows	7,150	RCP w/ CI Joints	666	160
90-inch Outfall	1957	Operational	10,394	RCP w/ CI Joints	2,416	196-210
120-inch Outfall	1966	Operational	11,880	RCP	4,440	167-190

RCP = reinforced concrete pipe

CI = cast iron

NA = not applicable

Source: Parsons 2011

5.6.1 Initial Tunnel and Ocean Outfalls

The Sanitation Districts' first tunnel and ocean outfall were placed in service in 1937. The 6-mile tunnel was horseshoe-shaped with a nominal diameter of 8 feet. It was lined with reinforced concrete, and to avoid the potential for sulfide corrosion, it was designed to flow full under all conditions. The accompanying outfall system was double-barreled past the surf zone. It consisted of two 60-inch diameter reinforced concrete pipelines with a wall thickness of 7 inches. These pipes were placed in a trench that was blasted through the subsurface rock formation. Both pipes were then embedded in concrete. Past the surf zone, one pipe was bulk-headed and reserved for a future expansion. The other line was extended about one mile offshore, becoming the 60-inch outfall. The hydraulic capacity of the

original ocean discharge system was approximately 52 MGD. All initial operations used gravity flow. In 1942, the first pumps were installed to increase the system's capacity.

As influent flows continued to increase, the need to expand the ocean discharge system was identified. Although the second barrel was originally planned to be extended with a 60-inch diameter pipeline, the determination was made to upsize the diameter to 72 inches. The 72-inch outfall was placed in service in 1947, discharging at a depth of approximately 100 feet. In 1953, this outfall was extended about one and a quarter miles from shore, reaching a depth of approximately 160 feet.

5.6.2 Subsequent Tunnel and Ocean Outfalls

As tributary flows to the JWPCP continued to increase, it became apparent that expansion of the ocean discharge system was required for JWPCP effluent management. The approach consisted of a second 6-mile tunnel and a new outfall. This second tunnel was constructed and commissioned in four separate segments. Work commenced on the 12-foot diameter tunnel in 1948. The four segments were phased into operation in April 1949, December 1950, March 1954, and April 1958.

Concurrently with the construction of the 12-foot tunnel, the Sanitation Districts built a third ocean outfall off White Point. It was a 90-inch diameter reinforced concrete pipeline that extended approximately one and a half miles offshore to a depth of 210 feet. The 90-inch outfall was placed in service in 1957.

The fourth and final ocean outfall was constructed and placed in service in 1966. This was a 120-inch diameter reinforced concrete pipeline extending approximately one and a half miles offshore to a depth of 190 feet.

With the 90-inch and 120-inch outfalls in service, the gravity flow capacity of the ocean discharge system at zero tide is approximately 415 MGD. The gravity flow capacity when all four outfalls are in service is 475 MGD at zero tide. The maximum hydraulic capacity of the tunnel and ocean outfall system with pumping is approximately 675 MGD.

5.6.3 Emergency Diversion

The JWPCP has an emergency discharge location upstream of the tunnels. The Wilmington Drain is owned and operated by the Los Angeles County Department of Public Works (LACDPW). It parallels the JWPCP boundary to the west. A diversion structure at the JWPCP allows for emergency discharge of secondary effluent to Wilmington Drain just north of Lomita Boulevard. However, during major wet weather events, there is very limited capacity in the drain for any additional flows. If sufficient capacity were not available in the Wilmington Drain, the sewers tributary to the JWPCP could overflow and untreated wastewater could enter various water courses, such as the Dominguez Channel and the Los Angeles River.

5.7 Solids Processing

5.7.1 Background

One byproduct of wastewater treatment and purification is residual solids. These solids, typically referred to as *sludge*, are further processed to convert organic matter into an energy-rich biogas and to produce a stabilized material, called *biosolids*, that is safe for various beneficial uses or disposal options.

This section discusses the primary systems employed for solids processing including:

- Sludge thickening
- Sludge stabilization
- Sludge dewatering
- Digester gas handling and power generation

Solids generation sources and solids processing systems are described in the sections that follow. A 5-year timeframe (2005 through 2009) was evaluated to obtain a representative perspective on solids processing and solids generation rates, which tend to vary with changes in population and economic conditions (i.e., industrial flow rates are generally lower during poor economic times). This 5-year data set provided recent information over a sufficient duration such that the results reflect the full spectrum of influent and operational scenarios impacting solids production.

5.7.2 Solids Sources

Within the JOS, the residual solids from each of the WRPs are returned to the JO trunk sewers and conveyed to the JWPCP along with tributary raw wastewater. Residuals from the WRPs consist of primary solids, skimmings, scum, and waste activated sludge (WAS). The wastewater treatment processes at the JWPCP remove nearly all of the influent- and process-generated solids prior to effluent disposal. The following are the major sources of solids.

- Primary Solids: Residuals removed from the primary sedimentation tanks consisting of solids settled out of the raw primary sludge (RPS) during primary treatment.
- Secondary Solids: WAS generated within the activated sludge process and separated from the secondary effluent in the final sedimentation tanks.

Skimmings and scum removed at different stages of wastewater processing are also included within the solids processing systems. The quantities of these materials, relative to RPS and WAS, are small and, therefore, are not evaluated in detail within this document. Other small quantities of solids, such as grit or screenings removed at the headworks, are managed separately from the primary and secondary solids.

5.7.3 Sludge Thickening

The thickening strategy for RPS and WAS differ. RPS is not thickened, while WAS is thickened using dissolved air flotation units. Polymer is added as a flotation aid to the units to enhance performance by increasing the solids concentration and percent capture.

There are a total of six dissolved air flotation units with a total surface area of 5,394 square feet (sf). The original four units make up 4,484 sf of area, with the two new units accounting for the remaining 910 sf. The design overflow rate is 1.84 gallons per minute (gpm)/sf; the design solids loading rate is 19.4 pounds per day (ppd)/sf. These units currently process close to 500,000 ppd of WAS. The WAS flow rate prior to thickening is approximately 6.3 MGD. The solids concentration of the WAS is increased from 1.0 percent to 5.5 percent by the dissolved air flotation thickeners. The product of this process is termed thickened waste activated sludge (TWAS) and represents a flow of approximately 1.1 MGD.

This thickening step is important in terms of reducing the volume of WAS to be handled in subsequent processes. The thickening systems have been recently upgraded and expanded.

5.7.4 Sludge Stabilization

Anaerobic digestion is used to stabilize RPS, TWAS, skimmings, and scum, collectively referred to as combined raw sludge (CRS), generated within the liquid treatment train. The digesters are operated as single-stage, high-rate units that use steam injection for heating and gas recirculation for continuous mixing. There are 24 conventional circular digesters, each with a volume of 500,000 cubic feet. This results in a combined volume of nearly 90 million gallons (MG). All of the JWPCP's original rectangular digesters have been removed from service and permanently decommissioned.

The average detention time is on the order of 15 to 18 days with two units out of service. Typically, at any time, there is one digester out of service for cleaning and another out of service on standby. The standby unit can be placed into service on short notice should there be a need to take any active digester off-line. Digesters are heated and mixed to optimize performance. The operating temperature is 96° Fahrenheit, providing a mesophilic environment. Biosolids produced meet Class B requirements for pathogen and vector attraction reduction.

The RPS flow to the digesters is approximately 3.4 MGD (474 dry tons per day [dtpd] at 3.32 percent solids); the TWAS flow to the digester is approximately 1.1 MGD (261 dtpd at 5.52 percent solids.) The CRS to the digesters has a volatile solids concentration of approximately 75 percent. Based on past performance, the volatile solids destruction in the digesters is about 53 percent (with the volatile solids being converted into biogas). The end product of digestion is stabilized sludge suspended in a liquid slurry.

5.7.5 Sludge Dewatering

Sludge dewatering reduces the volume of the material and changes its form from a liquid to a cake. This volume-reduction/form-change allows for the subsequent transport of biosolids by truck.

All digested sludge is mechanically screened prior to dewatering. Materials screened out are dewatered using a ram press. These screened materials, termed *unclassified solids*, are typically managed via landfilling. The majority of the digested sludge is dewatered using centrifuges with a polymer addition that improves solids recovery and increases the cake dryness. Of the 35 centrifuges now in use at the JWPCP, 27 are older units and eight are newer high-speed units that have a higher capacity and produce higher cake solids. (Note that four more new high-speed centrifuges are scheduled for installation in 2012.) The stabilized sludge from the digesters is approximately 2.2 percent solids. The solids cake produced from the centrifuges is approximately 26 to 28 percent solids. This represents a materials volume reduction of about 90 percent. The older low-speed, low-capacity centrifuges are being phased out of operation and replaced with newer technology systems, thereby increasing cake solids and reducing the overall volume of wet cake to be managed.

Dilution water is added to the centrate (the water removed during the dewatering process) to reduce the potential for scaling and deposition formation. Centrate flows are treated in dissolved air flotation units dedicated to this function. The underflow (liquid) can be returned to either the head of the plant, or upstream of the secondary treatment process. The float or skimmings (solids) are conveyed to the digested sludge wet well upstream of the dewatering centrifuges.

The cake produced by the centrifuges is transported by belt conveyors, stored in silos, and then loaded into trucks for offsite management. There are a total of 18 biosolids cake silos with a storage capacity of 500 wet tons per silo, resulting in a total storage capacity of 9,000 wet tons. At the recent (2005–2009) biosolids generation rate of approximately 1,470 wet tons per day (wtpd), about 6 days of storage is provided. There are three separate truck loading stations serving the JWPCP with loading rates of approximately 175 tons per hour.

Recently, facilities were placed into operation to control odors from the biosolids storage silo building, biosolids conveyors, and Truck Loading Station No. 3. The new systems include facilities for odor containment, foul air transport, and air treatment, using two independent biofilter treatment systems.

5.7.6 Gas Handling and Power Generation

A significant portion of the organic solids in the CRS is converted to gas through the anaerobic digestion process. This digester gas is approximately 63 percent methane and 37 percent carbon dioxide, capable of providing the Sanitation Districts with a significant fuel source. Approximately 6,900 cubic feet per minute (cfm) of gas is generated by the digesters. The digester gas is treated to reduce moisture and sulfur content prior to use. The purified gas is used to generate electricity by a combined cycle power plant.

First stage power generation uses gas turbines driving generators. This produces approximately 18 to 20 megawatts (MW) of electricity. Heat is recovered from the combustion turbines and used to generate steam. This steam is directed into a second stage steam turbine that drives a generator capable of producing 4 to 6 MW of electricity. The low grade residual steam and hot water from the outlet of this turbine, as well as low quality steam from boilers, are used for digester heating. The gas turbine generators were replaced and upsized in 2001. The steam turbine generator is being replaced with completion expected in late 2011. There are also flare stations at the JWPCP to assist in the management of the digester gas.

5.8 Biosolids Management

5.8.1 Biosolids Management History

After startup of the JWPCP in 1928, solids generated by the treatment processes were dewatered in open-air drying beds located on site. Recycling of these solids began in the same year when H.C. Kellogg entered into a contract with the Sanitation Districts to remove the dry material from the beds for use in a biosolids-based soil amendment product. In the 1930s, the Sanitation Districts constructed their first anaerobic digesters for solids stabilization, reducing the amount of solids needing to be managed and improving solids characteristics for both air-drying and reuse.

The first solids dewatering centrifuges were installed at the JWPCP in 1961. In 1972, the Sanitation Districts began windrow composting of biosolids at the JWPCP on a trial basis. Composting was found to accelerate the air-drying process, as well as producing a high-quality, stabilized soil amendment suitable for a wide range of agricultural and landscaping uses. The JWPCP composting operation continued until 1991, when it was moved offsite to a privately operated composting facility. Compost products were bagged for consumer use, and a portion was marketed in bulk quantities to plant growers. In addition to enabling windrow composting at the JWPCP, the installation of centrifuges also allowed for efficient transport of biosolids via truck. In the 1970s, the Sanitation Districts began co-disposal of

biosolids with refuse at the Puente Hills Landfill, which has continued to be a safe, reliable, and cost effective management option.

The 1972 Clean Water Act required secondary treatment for all effluent and included a prohibition of wastewater sludge discharge into navigable waters. At this time, the JWPCP was providing primary treatment, and the requirement for secondary treatment would result in greater quantities of wastewater sludge to be treated and managed. In 1974, the Sanitation Districts, the city of Los Angeles, and the Orange County Sanitation District, in association with EPA Region IX and the SWRCB, jointly developed a Regional Wastewater Solids Management Program for the Los Angeles/Orange County Metropolitan Area (also known as the LA/OMA Project).

The objective of the effort was to develop a long-term plan for the reuse and disposal of wastewater treatment residual solids. One key finding of this program for the Sanitation Districts was that future biosolids management strategies must include sufficient flexibility, through the incorporation of a diverse range of management options, to accommodate uncertainties inherent in biosolids management. This principle continues to serve as a guide for the Sanitation Districts' current and future plans. In addition, the Sanitation Districts co-dispose biosolids at the Puente Hills Landfill.

5.8.2 Biosolids Strategy

The Sanitation Districts' preferred approach to biosolids management is to implement a diverse and cost-effective program that includes beneficial use. Diversity is achieved in terms of multiple contractors, locations of use and application, additional offsite processing, a variety of products created, and different types of biosolids applications. To maintain this diversity, the Sanitation Districts' current philosophy of biosolids management is to have no more than 50 percent of their biosolids sent to any one vendor, or to any one location, including Sanitation Districts-operated facilities. The Sanitation Districts will continue to focus on the beneficial use of biosolids in the agricultural sector, develop uses in renewable energy as technology becomes readily available, and continue to utilize landfill co-disposal as a reliable, cost-effective solution for biosolids management.

5.8.3 Recent Management Practices

The Sanitation Districts' solids processing and biosolids management programs meet all regulatory requirements including those specified in 40 Code of Federal Regulations (CFR) Part 503. Biosolids generated at the JWPCP meet EPA Class B pathogen reduction requirements by Alternative 2, Use of Processes to Significantly Reduce Pathogens, through time and temperature requirements for anaerobic digestion. Vector Attraction Reduction requirements are met by Option 1, Reducing the Mass of Volatile Solids During Anaerobic Digestion. JWPCP biosolids are sampled monthly and analyzed for total metals concentrations. Since the 1993 promulgation of the 40 CFR Part 503 regulations governing biosolids management, the JWPCP biosolids have consistently complied with the most stringent requirements related to metals concentrations.

The majority of biosolids are beneficially reused in connection with agriculture as follows:

- Composting and production of soil amendment products marketed for bulk and bagged sale
- Composting and land application
- Lime stabilization and land application
- Land application of dewatered Class B biosolids

Biosolids produced at the JWPCP are further processed and beneficially reused at several regional locations as shown on Figure 5-15. Composting facilities utilized include the Inland Empire Regional Composting Facility in Rancho Cucamonga, California; South Kern Composting Facility in Kern County; and San Joaquin Composting in Kern County. Various composting technologies are employed at these facilities, such as windrow composting and aerated static pile composting. The Inland Empire Regional Composting Facility is an entirely enclosed composting facility.

JWPCP biosolids are also directly land applied to farmland for use as a soil amendment at several locations. Biosolids are applied at Honey Bucket Farms in Kern County, where the material is lime stabilized prior to land application. Direct land application of Class B biosolids operations are managed by EnerTech Environmental, LLC, on agricultural land in Arizona.

The Sanitation Districts have also entered into a long-term management agreement with EnerTech Environmental, LLC, to process biosolids into a renewable fuel product called eFuel. The facility, located in Rialto, California, utilizes EnerTech's patented SlurryCarb process, which is designed to efficiently create a renewable alternative to coal for power plant and cement kiln operations. This facility began operations in late 2008.

Until the recent economic downturn reduced the demand for cement, a small portion of the biosolids was used by the Mitsubishi Cement Corp. The biosolids were injected into a cement kiln to reduce emissions such as nitrous oxide. As economic conditions warrant, this management option may again be implemented in the future.

A summary of JOS biosolids management practices for the year 2010 is provided in Table 5-8.

Table 5-8. Biosolids Management Practices Summary

Contractor	Management Practice	Site	Percent of Total
McCarthy Family Farms, Inc.	Bulk Land Application Class A Compost Product	San Joaquin Composting Kern County, CA	16.8
Synagro-WWT, Inc.	Bulk Land Application Class A Compost Product	South Kern Industrial Center Composting Facility Kern County, CA	11.0
Inland Empire Regional Composting Authority	Bulk Land Application Class A Compost Product	Inland Empire Regional Composting Facility Rancho Cucamonga, CA	15.9
Honey Bucket Farms	Bulk Land Application Class A Lime Stabilized Material	Honey Bucket Farms Kern County, CA	11.0
EnerTech Environmental, LLC	Biosolids Conversion to Pelletized Fuel	Rialto SlurryCarb Facility San Bernardino County, CA	5.6
	Direct Land Application Class B Biosolids	Desert Ridge Farms Yuma County, AZ	9.2
Sanitation Districts of Los Angeles County	Landfill Co-disposal	Puente Hills Landfill Los Angeles County, CA	30.5

5.8.4 Landfill Co-Disposal

Co-disposal of biosolids with municipal solid waste at landfills continues to be a viable option for biosolids management. Landfills utilized are appropriately permitted for biosolids co-disposal. The focus of biosolids management will continue to be on beneficial reuse, while maintaining the ability to use landfilling. In 2010, approximately 31 percent of the total biosolids produced at the JWPCP were co-



FIGURE 5-15

disposed with municipal solid waste at the Puente Hills Landfill, where landfill gas (LFG) containing methane is extracted from decomposing refuse and utilized for electrical power generation. Although co-disposal is not considered a direct beneficial reuse, the inclusion of biosolids within a landfill can lead to increased methane production, and thereby lead to enhanced energy recovery.

5.8.5 Future Solids Management

During the planning period, the JOS biosolids generation rate is projected to increase nearly 30 percent, from 1,470 wtpd (2005–2009) to 1,850 wtpd (2050). This increase is attributable to several factors, including, but not limited to, the population increase within the Sanitation Districts' service area; increased JOS flows; changes in wastewater influent quality; and upgrades, optimization, and new technology at the JWPCP.

The Puente Hills Landfill, where nearly a third of the biosolids generated in the JOS are currently being managed, is scheduled to close in 2013, so the Sanitation Districts will need to rely more heavily on other management practices.

In addition to the recent biosolids management practices previously described, the Sanitation Districts' long-range plans for biosolids management include the ownership and operation of a new state-of-the-art composting facility in Kings County, California, called the Westlake Farms Composting Facility, shown on Figure 5-15. In 2001, the Sanitation Districts purchased 14,500 acres of land and entitlements to construct the composting facility. Using a covered aerated static pile composting technology, the Westlake Farms Composting Facility will compost Sanitation Districts' biosolids, green waste from Central Valley and Southern California communities, and agricultural wastes from the Central Valley. The compost product will be used on adjacent agricultural land. Agricultural wastes have specifically been included as feedstocks to improve air quality by providing an outlet for material that otherwise may have been open burned in the field. Biofilter technology will be used to control odors and air emissions from the facility, along with state-of-the-art covers designed specifically for odor and air emission control from aerated static piles.

The Westlake Farms Composting Facility is permitted to ultimately receive up to 500,000 wet tons per year (wtpy) of biosolids. Phase 1, which will be able to accommodate up to 100,000 wtpy of biosolids, is currently under construction and scheduled to begin operations in 2013. Future phases will be constructed in increments of 100,000 wtpy. The Westlake Farms Composting Facility will further diversify the Sanitation Districts' portfolio for biosolids beneficial uses, advancing the agency's long-term commitment to resource recovery.

The Sanitation Districts will continue to receive and analyze proposals from contractors to manage biosolids, and may enter into agreements for use of sites and technologies that will maintain a diversified portfolio of options. The Sanitation Districts may also continue to develop additional facilities to serve these same purposes, either individually or in partnership with the public and/or private sector. The Sanitation Districts may either own or jointly own any such facilities, and also may directly operate or contract for the operation of any such facilities.

Siting of these facilities would be located regionally, as determined by the participation of any private and public sector partners, the location of any materials needed for processing of biosolids, and the location for the reuse of any end products. These areas may include:

- All counties in the state of California

- The state of Arizona
- Other U.S. states and territories, if applicable
- Foreign countries that desire biosolids, or biosolids derived products, for reuse and/or processing

Transportation of biosolids to management facilities is currently handled by truck, but may be transported by rail or other modes of transportation in the future. The current locations of landfill and composting facilities within a 100-mile radius of the JWPCP that accept wastewater biosolids for beneficial use and disposal are listed in Table 5-9.

Table 5-9. Landfill and Composting Facilities Within a 100-Mile Radius of the JWPCP^a

Location	Estimated Distance	Types of Waste Accepted
Griffith Park Composting Facility 5400 Griffith Park Dr., Los Angeles, CA 90027	26.1	Sludge (Biosolids), Manure, Green Materials
Puente Hills Landfill 13130 Crossroads Pkwy South, Industry, CA 91746	27.7	Agricultural, Ash, Construction/Demolition, Industrial, Mixed Municipal, Sludge (Biosolids), Tires
Rancho Las Virgenes Composting Facility 3700 Las Virgenes Road, Calabasas, CA 91302	46.1	Sludge (Biosolids), Green Materials, Wood Waste
Simi Valley Landfill and Recycling Center 2801 Madera Road, Simi Valley, CA 93065	57.3	Construction/Demolition, Industrial, Mixed Municipal, Sludge (Biosolids)
Inland Empire Regional Composting Facility 12645 Sixth Street, Rancho Cucamonga, CA 91730	59.4	Green Materials, Sludge (Biosolids)
San Onofre Landfill 2.7 Miles East of Basilone Gate, Camp Pendleton (Mil Res), CA 92672	61.5	Industrial, Mixed Municipal, Construction/Demolition, Sludge (Biosolids)
Las Pulgas Landfill 1 Mile North of Camp Pulgas, Off Basilone Rd, Camp Pendleton (Mil Res), CA 92055	74.4	Construction/Demolition, Industrial, Mixed Municipal, Sludge (Biosolids)
California Street Landfill 2151 Nevada Street, Redlands, CA 92373	75.0	Mixed Municipal, Construction/Demolition, Sludge (Biosolids)
One Stop Landscape Supply Center 13024 San Timoteo Canyon Road, Redlands, CA 92373	77.9	Sludge (Biosolids), Agricultural, Wood Waste
Toland Road Landfill 3500 North Toland Road, Santa Paula, CA 93060	78.6	Mixed Municipal, Construction/Demolition, Agricultural, Industrial, Sludge (Biosolids)
San Timoteo Sanitary Landfill San Timoteo Canyon Road, Redlands, CA 92373	80.3	Agricultural, Construction/Demolition, Dead Animals, Industrial, Inert, Mixed Municipal, Sludge (Biosolids)
Lancaster Landfill and Recycling Center 600 East Avenue F, Lancaster, CA 93535	93.4	Agricultural, Construction/Demolition, Industrial, Mixed Municipal, Tires, Inert, Green Materials, Asbestos, Sludge (Biosolids), Contaminated Soil
Ojai Valley Waste Water Treatment Plant 1072 Tico Road, Ojai, CA 93023	94.0	Sludge (Biosolids)

^a Per the California Integrated Waste Management Board's website (as of November 1, 2008).

5.9 Joint Outfall System Needs Assessment

System needs can be determined by comparing existing capabilities against future projected requirements. The existing system capabilities are outlined within this chapter; projected requirements are summarized in Chapter 4. This assessment of needs forms the basis for options and alternatives formulation contained

within Chapter 6. With respect to projections, the future conditions of specific interest relate to anticipated growth within the JOS, as well as any potential new regulatory requirements that may affect the capabilities and adequacy of existing facilities.

This needs assessment is divided into five major facilities categories, as follows:

- Wastewater conveyance and treatment
- Solids processing
- Biosolids management
- WRP effluent management
- JWPCP effluent management

The needs identified and discussed are limited to those that may be associated with the construction of substantive, new improvements over the duration of the planning period. Needs associated with minor improvements or operational enhancements are not discussed.

5.9.1 Conveyance System

The conveyance system needs were developed by comparing the hydraulic carrying capacity of the JOS sewers to projected future flows. The conveyance system is distributed across the entire JOS service area such that individual pipeline segments must be compared to specific tributary flows. The assessment of flows versus capacity is complicated by the system's inherent flexibility that allows for flow diversions and thereby the ability to change tributary flows. In addition, the volumes extracted and treated by the WRPs also impact the flows seen by downstream conveyance facilities.

The Sanitation Districts have developed a static GIS conveyance system model that serves as a tool for analyzing the JOS conveyance system as well as providing a graphical display of the results. The model currently contains the JO trunk sewers and District trunk sewers but was calibrated with an emphasis on the JO trunk sewers. Calibration was conducted by comparing modeled flows against non-peak recorded flows (i.e., observed peak flows adjusted to reflect average daily flows), or estimated peak flows indicated on the sewer clearance diagrams. The modeled flows were based on average dry weather flows. The conveyance system configuration in the model (calibration configuration) reflects the current sewer system configuration.

The assessment of future needs was based on a comparison of projected tributary flows versus conveyance system capacity. The conveyance capacity was determined using the static GIS conveyance system model's baseline configuration. The baseline configuration consists of the calibrated configuration plus those projects previously identified and expected to be implemented within the near future (baseline projects). The addition of these projects also introduces a number of conveyance system configuration adjustments in terms of flow splits and diversion structure settings. A capacity need was identified as those pipeline segments for which the static GIS conveyance system model determined that the depth of peak dry weather flow (d) within the pipe was equal to, or greater than, 90 percent of the pipeline's diameter (D) (i.e., $d/D \geq 0.9$).

A detailed tabulation by pipeline segments and a graphical presentation were then developed from the static GIS model data. Using the static GIS conveyance system model and the criteria as discussed, potential areas where the conveyance system capacity may be exceeded have been identified. Overall, it is estimated that 43.7 miles of JO trunk sewers would need to be hydraulically relieved by the year 2050.

(Note that this estimate would be reduced if the increased wastewater flows were accommodated through expansion of one or more upstream WRPs rather than an expansion of the JWPCP.) The extent of capacity needs predicted for the JO trunk sewers is provided in Table 5-10 and graphically depicted on Figure 5-16.

Table 5-10. Projected Conveyance System Capacity Needs

JO Trunk Sewers	Total Length (miles)
Joint Outfall A	11.1
Joint Outfall B	15.5
Joint Outfall C	0.5
Joint Outfall D	1.0
Joint Outfall E	1.3
Joint Outfall F	3.5
Joint Outfall G	0.9
Joint Outfall H	9.7
Joint Outfall J	0.1
Total	43.7

Based on the duration of the planning period and the projected increase in system flows over that period, the extent of potential conveyance system capacity deficiencies identified by the static GIS conveyance system model appears to be a reasonable approximation. The projected conveyance system needs are comparable with the current rate of sewer improvement projects implemented annually. Actual future needs will vary depending upon a variety of factors such as future growth patterns and WRP expansions. As a result, the conveyance system improvements implemented will be based on continued monitoring of actual conveyance system performance and will represent the optimal combination of relief, rehabilitation, and replacement projects for the entire system.

5.9.2 Treatment Plants

The potential deficit in treatment plant processing capabilities was determined by calculating the difference between projected future tributary flows and the current JOS treatment capacity on a plant-by-plant basis. The results of this analysis are summarized in Table 5-11.

Table 5-11. Projected Joint Outfall System Treatment Plant Capacity Needs

Treatment Plant	Tributary Population	Current Permitted Capacity (MGD)	2050 Tributary Flow (MGD)	Treated Flow (MGD)	Bypassed/Exceeded Flow (MGD)
POWRP	129,919	15.0	13	13	0
SJCWRP	1,396,684	100.0	135	100	35
WNWRP	481,926	15.0	44	15	29
LCWRP	398,819	37.5	41 ^a	38	3
LBWRP	264,773	25.0	23	23	0
JWPCP	3,180,740	400.0	423 ^b	400	23
JOS Treated Flow				589	
JOS Exceed Flow				23	
JOS Total	6,257,614	592.5		612	

^a LCWRP inflow includes 10 percent of WRNP bypass flow, with the remainder of the WRP bypass flow contributing to JWPCP inflow.

^b JWPCP flow is the sum of the projected flow for the JWPCP tributary area plus upstream WRP bypassed flows.



FIGURE 5-16

Conveyance System Needs

Overall, the current combined permitted capacity of the JOS treatment plants is 592.5 MGD. Taking into account the total system's existing capacity versus the 612 MGD JOS flow projection for 2050 (derived in Chapter 4), it is estimated that a minimum of approximately 20 MGD of additional treatment capacity is required during the planning period. Depending on the flows tributary to specific treatment plants and the capacities associated with modular plant expansions, the future combined system capacity in some cases may need to exceed this minimum value. As shown on Figure 5-17, it is anticipated that the permitted treatment capacity of the JOS plants will not be exceeded until between 2040 and 2050.

In addition, the recent addition of NDN at the WRPs has made the plants more sensitive to peak hydraulic flows and nutrient loadings. Therefore, as flows approach the permitted capacities of the WRPs, it may be necessary to implement process optimization measures, such as the addition of flow equalization, to ensure that the Sanitation Districts continue to consistently meet permit conditions in anticipation of increasingly stringent regulatory requirements.

5.9.3 Solids Processing

The solids processing systems of principal concern are:

- Sludge thickening
- Sludge stabilization
- Sludge dewatering
- Gas handling and power generation

Each of these is discussed separately in terms of projected future capacity needs, potential facilities, and the timing for implementation.

5.9.3.1 Sludge Thickening

The capacity of the existing dissolved air flotation thickener system is estimated to be 11.32 MGD. The projected future WAS flow for 2050 is 7.80 MGD, resulting in a surplus thickening processing capacity of 3.52 MGD. Therefore, it is concluded that no additional thickening systems will be required over the duration of the planning period.

5.9.3.2 Sludge Stabilization

The capacity of the existing anaerobic digestion system is estimated to be 4.58 MGD. This means that the existing system is close to or at capacity. The projected future CRS flow for 2050 is 5.62 MGD, resulting in a processing deficit of 1.04 MGD. To accommodate this processing deficit, six additional anaerobic digesters will be required. It is anticipated that additional capacity would be in the form of units of similar design to those existing. The timing for construction of these facilities is dependent upon the future trending of sludge production at the JWPCP.

5.9.3.3 Sludge Dewatering

The projected future digested sludge flow for 2050 is 5.62 MGD. Sludge dewatering is currently being handled by a mix of centrifuges of various ages. The total capacity of the JWPCP sludge dewatering system can handle the projected flow. The Sanitation Districts should continue the existing program of replacing aging centrifuges as needed throughout the duration of the planning period.

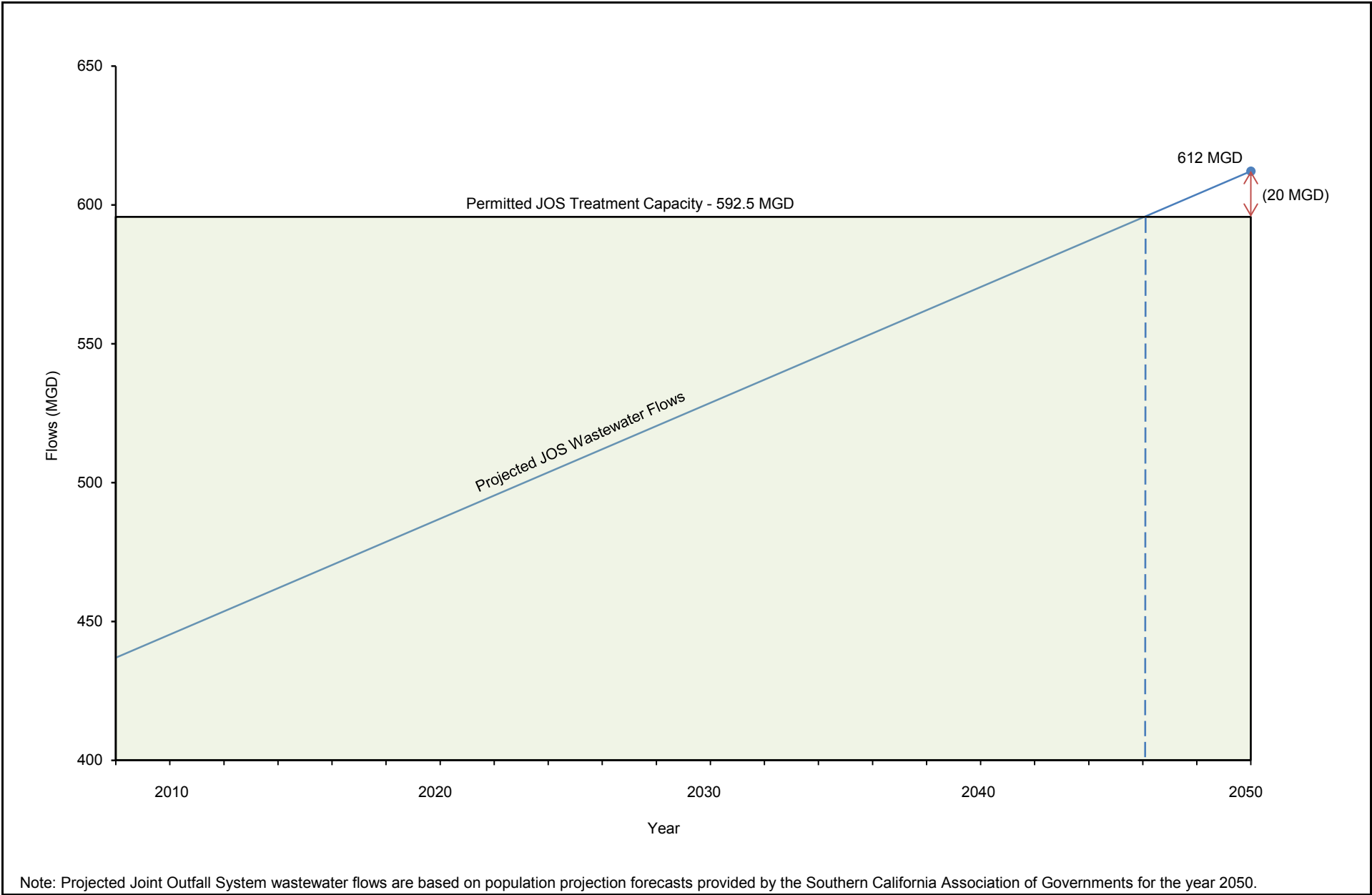

FIGURE 5-17



Projected 2050 JOS Flows Versus Total Existing Permitted Capacity

Source: Sanitation Districts of Los Angeles County 2011

5.9.3.4 Gas Handling and Power Generation

The power plant at the JWPCP currently utilizes two turbines that run on digester gas, a third turbine that is used for standby, four boilers that create steam from digester gas for process heating, and twelve flares that burn excess digester gas. Additional gas resulting from an increased number of digesters could be managed by these facilities. The turbines are currently supplemented with natural gas. As digester gas increases, it could be used in lieu of natural gas.

5.9.4 Biosolids Management

During the planning period, it is projected that the JOS biosolids generation rate will increase nearly 30 percent, from 1,470 wtpd (2005–2009) to 1,850 wtpd (2050), as shown on Figure 5-18. The Sanitation Districts currently have a robust and diverse system in place to address the projected increase. This includes a collection of different private contractors who provide for beneficial use of the biosolids product. These contractors employ a variety of post-dewatering treatments, with biosolids being applied at a range of locations, using a number of different application methods. The Sanitation Districts also have the ability to co-dispose biosolids in landfills, but this option will become more restrictive with the scheduled closure of the Puente Hills Landfill in 2013. However, the planned 500,000-wtpy Westlake Farms Composting Facility should be operating at 20 percent of permitted capacity by the same year, and can be expanded in phases if and when future needs arise. Therefore, it is anticipated that there is no additional physical infrastructure required to accommodate future biosolids management. The Sanitation Districts should continue to explore options that provide for additional biosolids management diversity and further optimize the beneficial use of these materials.

5.9.5 Water Reclamation Plant Effluent Management

The existing system of WRP effluent management is effective and provides the Sanitation Districts flexibility with respect to providing recycled water for reuse and discharging any excess flows to surface waterways. All indications are that the demand for recycled water will continue to increase over time. This increase could also result in the potential need for storage and possibly higher levels of treatment. While there are no capacity limitations associated with surface water discharges, if more restrictive effluent requirements are implemented in the future by state and federal regulatory agencies, the current plant capacities and/or treatment process trains could be affected.

5.9.6 Joint Water Pollution Control Plant Effluent Management

JWPCP effluent management relies entirely on ocean discharge. With pumping and both tunnels and all four ocean outfalls in operation, the maximum hydraulic capacity of the JWPCP ocean discharge system is 675 MGD, which was nearly exceeded during a series of storms in January 1995. JOS flows are projected to increase by the year 2050. If the JWPCP reaches its permitted treatment capacity of 400 MGD, the associated peak wet weather flows are projected to reach 927 MGD. If the increased wastewater flows were accommodated through expansion of the JWPCP rather than one or more upstream WRPs, the associated peak wet weather flows are projected to be even higher.

Furthermore, the 60-inch diameter ocean outfall has nearly reached the end of its useful life, so it cannot be relied upon to manage future flows. Also, it is currently not possible to remove either of the tunnels from service to inspect their condition and make any necessary repairs. Neither of the tunnels has been inspected in over 50 years, and one of the tunnels has been in service for over 70 years. The Sanitation

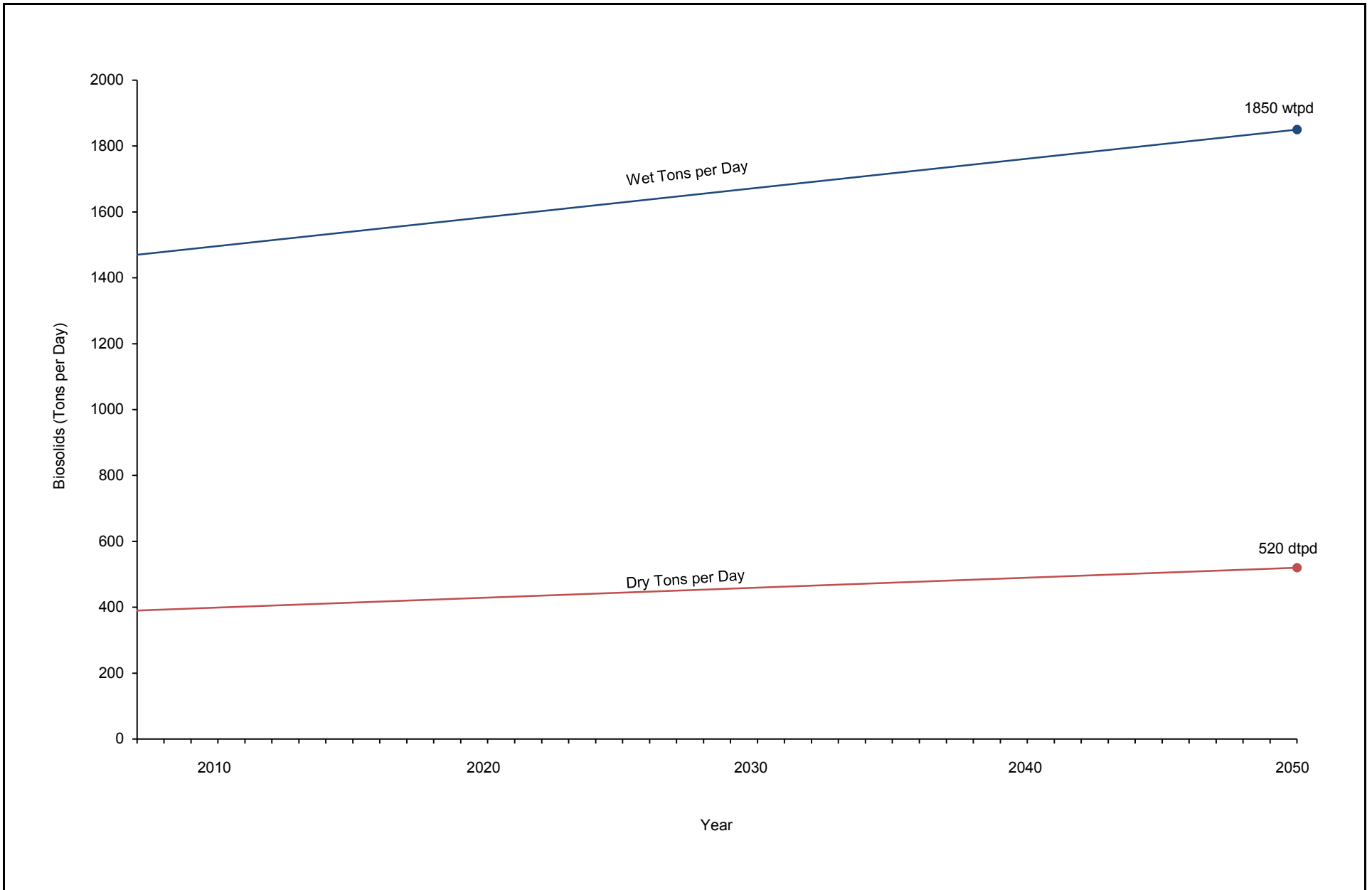

FIGURE 5-18



Projected 2050 JOS Biosolids Generation Rates

Source: Sanitation Districts of Los Angeles County 2011

Districts believe it is prudent to address this aging infrastructure concern in order to reduce the potential for the catastrophic failure of a key system component and provide redundancy for critical infrastructure.

Chapter 6

ALTERNATIVES ANALYSIS

6.1 Introduction

The overall goal of the Clearwater Program Master Facilities Plan (MFP) is *to identify a recommended plan that is protective of public health and will best meet the needs of the Joint Outfall System (JOS) through the year 2050 in a cost-effective and environmentally sound manner*. Recommendations consist of system improvements, upgrades, and expansions to accommodate projected future conditions within the service area. The future conditions of specific concern include anticipated growth within the system, an aging infrastructure, emerging demands for recycled water, and potential new regulatory requirements. This chapter presents the development, analysis, and screening of program-wide and project-specific alternatives within the framework of the regulatory requirements, existing conditions, and projected future conditions that have been established in the preceding chapters.

6.1.1 Chapter Organization

In this chapter, both program-wide and project-specific options and alternatives are analyzed. First, the program-wide options/alternatives are developed for the entire JOS. Second, project-specific options/alternatives are developed in connection with a single component area—Joint Water Pollution Control Plant (JWPCP) effluent management. Finally, the two sets of alternatives are grouped into plan alternatives and ranked, with a *recommended plan* being identified at the conclusion of the chapter.

6.1.2 Planning Objectives

The MFP is necessary to ensure adequate JOS wastewater system capacity, reliability, sustainability, and compliance through the year 2050. Specifically, the recommended plan in the MFP would need to meet the following objectives:

- *Provide adequate system capacity to meet the needs of the growing population*
- *Provide for overall system reliability by allowing for the inspection, maintenance, repair, and replacement of aging infrastructure*
- *Provide support for emerging recycled water reuse and biosolids beneficial use opportunities*
- *Provide a long-term solution for meeting water quality requirements set forth by regulatory agencies*

6.1.3 Managing Uncertainty

Planning efforts must always deal with some degree of uncertainty relating to projected future conditions versus the range of possibilities of what may actually occur. While projections are based on current available information and sound judgment, the limitations of these projections must be recognized, and flexibility should be incorporated into recommendations. Examples of the types of uncertainty and future changes that impact facilities planning include:

- **Regulatory:** Chapter 3 reviews current regulatory requirements. The potential exists for future additional constituents to be identified and regulated. Future requirements may also be more restrictive than current standards for existing regulated constituents.
- **Wastewater and Reuse:** Chapter 4 summarizes current and projected wastewater flows and characteristics, as well as recycled water reuse. Future projections are based on predictions of residential, commercial, and industrial growth; wastewater generation rates; and water reuse plans and studies. All these are subject to change over time.
- **Treatment and Technology:** Chapter 5 provides an overview of existing systems and projected needs. These needs may be affected by not only regulations and flows but also the treatment technologies that may be developed and available in the future.

The keys to managing these types of uncertainties relative to future conditions is to avoid narrowly tailored solutions that have limited capabilities to cope with change and to ensure that recommended systems have sufficient flexibility to accommodate a reasonable range of future conditions. This approach would permit the monitoring of actual future conditions against projected conditions and would allow appropriate adjustments as needed.

6.1.4 Public Input

Public input was an integral part of the overall alternatives development and analysis process. An extensive public outreach effort was conducted in conjunction with the Clearwater Program MFP and environmental impact report/environmental impact statement (EIR/EIS). Prior to conducting the alternatives analysis that follows in this chapter, the Sanitation Districts of Los Angeles County (Sanitation Districts) conducted a series of public workshops to solicit input on the plan objectives, screening criteria, and various program and project elements. Project engineers also met with over 500 community leaders, civic groups, public officials, regulatory agencies, environmental groups, and businesses. In addition, thousands of project newsletters were circulated, and a telephone information line and a website (www.ClearwaterProgram.org) were established to allow public input throughout the planning process.

6.1.5 Terminology

A set of nomenclature was developed to describe different elements of the alternatives analysis process. The basic terminology is outlined in the following sections.

6.1.5.1 Program Versus Project

The term *program* is used in reference to options or alternatives that are broad in nature and do not have a high level of detail. A program would be implemented in the long term. The term *project* is used to describe a specific component of the comprehensive plan. A project would be implemented in the short term, and a greater level of detail is required for its analysis in the MFP and the associated EIR/EIS. An example of a program would be the continuation of the Sanitation Districts' current biosolids management practices throughout the duration of the 2050 planning horizon. An example of a project would be the construction of a new or modified ocean discharge system within the next 10 years to address the effluent management needs of the JWPCP.

6.1.5.2 Program Component Areas

For the purposes of both needs assessment and options formulation, the JOS was divided into five program *component areas* based on primary functionality. These are:

- Wastewater conveyance and treatment
- Solids processing
- Biosolids management
- Water reclamation plant (WRP) effluent management
- JWPCP effluent management

These program component areas will be described in greater detail in subsequent sections. A similar breakdown was used for the project elements.

6.1.5.3 Options Versus Alternatives

Based on specific needs identified within the different program component areas, individual *options* were formulated and subjected to multiple levels of screening. The remaining options from each of the five program component areas were combined into logical, system-wide *alternatives*, which were subjected to additional screening.

6.2 Program Analysis by Program Component Area

The process for alternatives formulation and screening is described in Section 6.2.1. The rules and regulations with which all planned wastewater facilities must comply are outlined in Chapter 3. The projected future wastewater flows and characteristics are summarized in Chapter 4. The capabilities of existing systems, as well as potential needs based on projected future conditions, are provided in Chapter 5. The subsections that follow outline alternative approaches to meet the Clearwater Program objectives based on regulatory requirements, projected future conditions, and identified system needs.

6.2.1 Alternatives Development and Analysis Process

A large number of approaches were considered to meet the identified future needs of the JOS. Determination of the optimal approach in the form of a recommended plan required the systematic assessment, ranking, and screening of options and alternatives. This process is graphically depicted on Figure 6-1. Starting with a large number of potential approaches grouped into one of five program component areas, the total number of options/alternatives was reduced by a formal evaluation, screening, and ranking process resulting in a recommended plan.

6.2.1.1 Conceptual Options

The identification of specific needs by the program component areas of the JOS is provided in Chapter 5. On the basis of the identified needs, *conceptual options* were developed for each program component area. In the development of these options, approaches were formulated with respect to alignment with the Sanitation Districts' organizational values embodied within:

- The Sanitation Districts' mission statement
- The Clearwater Program's overall goal and objectives

JOINT OUTFALL SYSTEM – PROGRAM COMPONENT AREAS

**Conveyance/
Treatment**

**Biosolids
Management**

**Solids
Processing**

**WRP Effluent
Management**

**JWPCP Effluent
Management**

Conceptual Options – By Program Component Areas

LEVEL 1 SCREENING

PROGRAM OBJECTIVES

Preliminary Options – By Program Component Areas

LEVEL 2 SCREENING

COMPONENT
AREA SCREENING
CRITERIA

Viable Options – By Program Component Areas

COMBINE COMPONENT
AREA OPTIONS
INTO SYSTEM
ALTERNATIVES

Viable Program Alternatives

LEVEL 3 SCREENING

ALTERNATIVES
EVALUATION CRITERIA

Ranked Feasible Program Alternatives

ENVIRONMENTAL
ANALYSIS (EIR/EIS)

RECOMMENDED PROGRAM

FIGURE 6-1

The Sanitation Districts' mission statement is *to protect public health and the environment through innovative and cost-effective wastewater and solid waste management, and in doing so convert waste into resources such as recycled water, energy, and recycled materials*. The Clearwater Program's overall goal and objectives are provided in Section 6.1 and 6.1.2, respectively. The conceptual options represent a reasonable range of options available to the Sanitation Districts in providing comprehensive wastewater management within the JOS.

6.2.1.2 Level 1 Screening

The conceptual options by program component areas were evaluated with respect to compliance with Level 1 screening parameters.

Level 1 Screening Parameters

The Level 1 screening parameters were used to assess the conceptual options. Each of these parameters is briefly discussed in the paragraphs that follow.

Protection of Public Health

The Sanitation Districts are committed to the protection of public health. The evolution of proper sanitary practices, including wastewater management, has virtually eliminated waterborne disease in the United States and contributed to a longer life expectancy. The tertiary-treated recycled water produced by the Sanitation Districts essentially meets or exceeds state and federal drinking water standards and is safe for indirect potable reuse and unrestricted direct human contact. Because the continued protection of public health is an underlying goal of the MFP, a conceptual option must meet this screening parameter to be carried forward into the alternatives analysis.

Environmentally Sound and Cost-Effective Wastewater Management

An environmentally sound approach to wastewater management includes avoiding and/or minimizing potentially adverse impacts on the environment. During the initial stages of the planning process, the Sanitation Districts retained ICF International to begin preparing the associated EIR/EIS. ICF International also performed preliminary environmental impact assessments in support of alternatives analysis for the MFP.

A cost-effective approach to wastewater management entails taking into account total life-cycle costs of future infrastructure improvements and operations and maintenance (O&M) changes being considered for the JOS. External funding opportunities must also be identified and pursued. By planning in a fiscally responsible manner, the Sanitation Districts are able to ensure the continuation of affordable user rates.

In order to be further considered in the alternatives analysis process, a conceptual option must be both environmentally sound and cost effective.

System Capacity to Meet JOS Population Growth

The recommended plan must provide wastewater management facilities capable of handling flows generated within the JOS through the year 2050. In general, wastewater flows are expected to increase in proportion to population growth within the JOS service area. Population forecasts are derived from projections by the Southern California Association of Governments (SCAG). These projections are then converted to flows using a per capita generation rate. Contract and industrial flows are separately projected and added into the projected flow totals. Recent (2007–2009) average JOS flows were approximately 437 million gallons per day (MGD). Projected average JOS flows for the year 2050 are estimated at 612 MGD, representing a 40-percent increase. Peak wet weather JOS flows are also projected to increase during the planning period. The conceptual options for wastewater conveyance,

treatment, effluent management, and solids management must be capable of effectively handling the projected flows and loadings for the planning period to be carried forward into the analysis.

Maintaining Aging Infrastructure to Ensure System Reliability

Proper operation and maintenance of JOS assets is critical to protecting public health and safeguarding the environment. Ensuring reliable levels of service requires the means to routinely inspect and maintain infrastructure components and to repair, rehabilitate, or replace assets as determined necessary. System components and associated maintenance varies considerably. Structural elements, such as pipelines, buildings, and tanks, typically have longer useful life expectancies than other components. Mechanical systems, including pumps and blowers, can experience significant wear and tear, requiring system redundancy and routine rehabilitation or replacement. Electrical and control components, such as switchgear and distributed control systems, can similarly experience deterioration, or become technically dated, requiring upgrading or replacement. As a result, some level of asset redundancy is needed for all types of components to provide reliable operation in case of an unplanned outage as well as the ability to routinely inspect and maintain systems to prevent any interruption of service. Critical elements of the systems must, therefore, be capable of being removed from service for inspection and maintenance without negatively affecting the system's overall functional integrity. Seismic considerations, such as retrofits and redundancy, should also be provided for vital system components. If a conceptual option did not allow for inspections and necessary replacement, repair, or rehabilitation of vital system elements, it was eliminated from further consideration.

Accommodating Emerging Water and Biosolids Recycling Opportunities

Recognizing water supply limitations in a semi-arid, drought-prone area such as Southern California, the Sanitation Districts have actively engaged in water recycling and reuse for over half a century. Water reuse applications include landscape and agricultural irrigation, industrial uses/processes, recreational impoundments, wetland creation and river habitat, groundwater recharge, and seawater barrier creation. The Sanitation Districts do not directly distribute recycled water to individual customers. Agreements are negotiated with local water purveyors who, in turn, provide recycled water to their customer base.

The processing of solids and conversion of these materials into recyclable biosolids also provides environmental benefits. These benefits include the creation of soil amendment products and alternative fuels. These aspects of solids processing and biosolids management contribute to enriching the land, reducing irrigation demands, and improving air quality.

A conceptual option must not impede emerging recycling opportunities to reach the next stage of the alternatives analysis process.

Compliance With Applicable Regulations

The management of JOS wastewater treatment and effluent discharges is subject to an array of federal, state, and local regulations. The regulations of principal concern are outlined in the National Pollutant Discharge Elimination System (NPDES) permits and/or Waste Discharge Requirements (WDRs) for each plant and discharge location. These requirements and permits are consistent with federal and statewide regulations and are promulgated by the Los Angeles Regional Water Quality Control Board (LARWQCB). A conceptual option would need to allow for continued compliance with applicable regulations to be carried forward into the alternatives analysis process.

Application of Screening Parameters

Conceptual options were qualitatively assessed for consistency with the Level 1 screening parameters by applying professional judgment based on experience and readily available information. The conceptual

options that were determined to be impractical and/or unreasonable were eliminated from further consideration.

6.2.1.3 Preliminary Options

The smaller, more specific set of *preliminary options* for each program component area that were determined to be consistent with the Level 1 screening parameters were carried forward into the alternatives analysis.

6.2.1.4 Level 2 Screening

The preliminary options by program component areas were then evaluated for compliance with Level 2 screening parameters.

Level 2 Screening Parameters

For this stage of the assessment, program component area screening criteria were utilized. While a number of these criteria are common to all program component areas, some criteria are associated with specific program component areas. The application of a specific criterion was based on both its relevance to the program component area as well as its significance with respect to differentiating between the options under consideration. As an example, the conveyance systems impacts criterion is relevant to the wastewater conveyance and treatment (CT) program component area, and serves to differentiate between the options within that grouping. However, while the available land or right-of-way is relevant to the CT program component area, all of the CT options under consideration have facilities either located in public right-of-way or on Sanitation Districts' land. Therefore, this criterion provides no differentiation between options and, therefore, was not incorporated into the CT options analysis.

Each of Level 2 screening parameters is briefly discussed in the paragraphs that follow.

Conveyance System Impacts

The population projections for growth result in additional flows generated within different portions of the JOS. In some instances, depending on the JOS conveyance system configuration, these flows may be tributary to one or more WRPs, or could be bypassed to the JWPCP. In analyzing conveyance system impacts of the options put forward, the differential sewer relief requirements of these options were evaluated. The evaluation identified the tradeoffs between upstream WRP expansion and necessary sewer relief projects. A static geographic information systems (GIS) conveyance system model was an integral part of this evaluation process. When feasible, the Sanitation Districts generally give preference to options that provide for expansion to the WRPs in lieu of relief of the downstream sewer system. Large sewer relief projects increase project costs and can generate adverse environmental impacts during construction. Conversely, the WRP expansions provide substantial benefits in the form of increased availability of recycled water supplies for application to reuse opportunities. Options were compared relative to the magnitude of conveyance projects associated with implementation.

Treatment Plant Impacts

The primary impacts from treatment plants are associated with either capacity expansion to accommodate increased flow quantities or upgrades that provide for process optimization. The JOS plants have different capabilities to accept additional flows. Differences include:

- Currently available, unused capacity at a plant
- Differences in unit costs for expansion
- Non-cost considerations related to construction and plant expansion

The options assessment and scoring reflect the Sanitation Districts' preferences of providing capacity expansion/plant upgrades at the facilities with the lowest unit cost for improvements, minimizing the number of plants affected, and mitigating the non-cost impacts of expansions/upgrades to the extent required. One non-cost consideration evaluated in the assessment was impacts related to plant capacity expansions for facilities where competing uses exist for land space (e.g., recreational uses or flood control).

Resource Reuse

The primary resources generated within the JOS that are available for reuse are:

- Recycled water
- Digester gas
- Biosolids

Maximizing recycled water generally favored options that expand capacity at the WRPs rather than at the JWPCP. Some WRP expansion options were differentiated with respect to the location of a given WRP versus the location of the projected future recycled water demand. For reuse of digester gas, a byproduct of solids processing, all options are equal. Biosolids management options that provide a reliable, diversified program have the greatest potential for full reuse (e.g., composting and land application).

Sustainability

The term sustainability was applied in a relatively inclusive manner. Within the context of options analysis, the primary focus was the comparative evaluation of options related to the following considerations:

- Does the option in question increase or decrease the consumption of fixed resources relative to other options?
- Are products generated (e.g., recycled water) that can be used to avoid new resource consumption?
- Are there significant energy usage impacts and accompanying carbon footprint implications of an option?
- Are there substantial environmental and/or ecosystem impacts (i.e., beneficial or detrimental)?
- Are there significant socio-economic development impacts?

Options that create reusable products (e.g., recycled water) and are energy-efficient were preferred.

Available Land/Right-of-Way

While the land requirements and rights-of-way are important to any public works project, this parameter was only applied to the JWPCP effluent management options because of the implications associated with tunnel and ocean outfall options. The ability to procure land, easements, rights-of-way, permits, and approvals for both construction and operation were factored into the analysis. The areas with greatest potential for impacts are the shaft site locations. In general, options that minimize overall land requirements and the number of right-of-way procurements were ranked as preferred options under this criterion.

Institutional Feasibility

Institutional feasibility refers to the Sanitation Districts' ability to independently effect the implementation of the project, and the difficulty or feasibility of developing a project that is not wholly within the Sanitation Districts' control. The implementation of any of the options under consideration

necessitates the involvement and cooperation of a number of entities. Many of the requirements for reviews, approvals, and permits needed to implement specific options are outside the immediate purview of the Sanitation Districts. The fewer reviews, approvals, and permits required, the greater the institutional feasibility of an option. The anticipated level of cooperation of these external entities in providing reviews, approvals, and permits was factored into the relative options assessment. The need for inter-agency agreements was also included within this evaluation.

Regulatory Compliance

Much of regulatory compliance revolves around the procurement of discharge and/or reuse permits and the ability to maintain compliance with permit standards. Compliance was assessed with respect to the following criteria:

- The ability to meet all of the current requirements
- The ability to meet potential future requirements
- The need to negotiate permit limits or perform extensive research to justify alternative standards

While there is limited certainty associated with predicting future regulatory requirements, it is highly likely that the Sanitation Districts will face more stringent standards than those currently in place. Constituents identified as having the greatest potential for current and future impacts were N-nitrosodimethylamine (NDMA), total dissolved solids (TDS), ammonia, nutrients, emerging contaminants, and pesticides. These constituents were factored into consideration under this criterion. Those options with the least potential to require any type of exception to existing requirements and are most likely to meet new requirements were provided the most favorable assessment.

Public Acceptability

Public acceptability was used to compare options relative to their perceived level of support or opposition from different groups representing public opinion. Groupings included:

- Public officials
- Civic groups and individuals
- Business community
- Public agencies
- Environmental groups

It should be noted that the assessments represent a composite evaluation because different groups may have differing perspectives on the same option. Input was received from the public during the planning effort using public workshops, group and individual meetings, and the responses received from different informational media.

Operational Flexibility, Reliability, and Familiarity

Options were reviewed in terms of a number of operations-related criteria. Flexibility is an essential component of operations, allowing personnel to react to, and adjust for, changing conditions such as flow increases or influent quality variations. Within the wastewater collection system, this could consist of the ability to route flows to optimize the system's overall capacity. Such flexibility could become important in the case of a localized, high intensity storm event within one portion of the conveyance system. The ability to balance flows through diversions and bypasses could be critical to overflow prevention. In the case of treatment plants, flexibility relates to the ability to adjust process operational parameters to accommodate varying conditions. This could be as straightforward as having the ability to accommodate

higher constituent loading during a specific peak period. In general, the Sanitation Districts' preference is to implement systems with good operational flexibility, while avoiding a cost premium for such.

In general, all options developed for wastewater conveyance and treatment incorporate similar levels of reliability in terms of standby mechanical systems, redundancy of critical facilities, power supply backup, and instrumentation and control flexibility. As a result, there was not much differentiation with respect to reliability for conveyance/treatment options. However, in the evaluation of effluent and solids management options, reliability assessment was a more prominent consideration. The ability to reliably manage effluent and biosolids under a variety of different scenarios was assessed for these options.

The cost, reliability, and overall effectiveness of facilities' operations are significantly affected by the operational staff's familiarity with the systems involved. New facilities that are consistent with existing systems and processes were judged more favorably. Options that incorporated systems that were significantly different, or considerably more complex, than existing systems were evaluated less favorably.

Cost Effectiveness

The comparison between options relative to cost effectiveness included consideration of both initial capital costs and ongoing operation and maintenance costs.

These cost elements were combined and the different options compared in terms of their relative total present worth, or total life-cycle costs. (Detailed cost estimates were not developed for each option at this stage of the alternatives analysis process.) The ability to obtain potential external funding to defray cost impacts on ratepayers was also factored into this assessment. Options with comparatively lower life-cycle costs received more favorable assessments.

Application of Level 2 Screening Parameters

The options were scored against the previously discussed parameters and rated on a scale of plus, zero, and minus:

- + Rated superior with respect to other program component area options for a specific parameter
- 0 Rated neutral with respect to other program component area options for a specific parameter
- Rated inferior with respect to other program component area options for a specific parameter

The screening parameters are used as measures of an individual program component area option's relative merits in comparison to other options in that area, and scored accordingly. The scores were summed to develop a total score for each option.

6.2.1.5 Viable Options

Preliminary options that had the lowest total score or had a total score that was negative were eliminated from further consideration. Those with a higher total score were moved forward in the process and are termed *viable options*.

6.2.1.6 Level 3 Screening

Two of the program component areas produced more than one viable option: wastewater conveyance and treatment and JWPCP effluent management. For these program component areas, a third level of screening was performed. In the case of the CT program component area, the viable options were ranked against a set of criteria as described in Section 6.2.2.7. For the JWPCP effluent management program

component area, a separate project-level alternatives analysis was conducted as described in Section 6.3. The results from the Level 3 screening were a set of ranked feasible options for each program component area.

6.2.1.7 Plan Alternatives

Program component area options represent the building blocks for comprehensive, system-wide alternatives. In this step of the process, individually ranked feasible options were combined into plan alternatives. These plan alternatives were ranked based on the results of the program-level and project-level alternatives analyses. The recommended plan represents the top-ranked alternative as identified in Section 6.4 and detailed in Chapter 7.

6.2.2 Wastewater Conveyance and Treatment (CT)

6.2.2.1 Conceptual Options

The primary function of the conveyance and treatment system is to collect, convey, and treat all existing and future wastewater flows within the JOS to a level consistent with discharge and water reuse requirements. Options were separately formulated for the conveyance and treatment program elements. The conveyance options were formulated in support of specific treatment strategies. For the purposes of the MFP, options related to conveyance were limited to major new interceptors and relief sewers that impact the JOS' overall capabilities and operations. Therefore, tradeoffs between WRP expansion and increases to downstream interceptor capacity can be evaluated. Additional interceptor capacity would be provided where hydraulic constraints are identified under peak dry weather flow conditions within the Joint Outfall (JO) trunk lines. The addition of conveyance capacity could result from:

- Identified capacity deficits within the existing conveyance system related to current or future projected flows
- Needing to change the flow distribution among the various WRPs and the JWPCP
- Maintaining the routing of low quality flow around the WRPs so as to maximize the reclamation potential of the WRPs

The treatment variables that may affect requirements for new sewer capacity include the site capacity of a WRP, the anticipated future reuse demands near the site, and the expansion costs relative to other WRPs. Because of this dependency on selected treatment approaches to establish conveyance options, no independent conceptual options were formulated for the conveyance program element.

Chapter 4 provides the basis for projecting future flows and characteristics, and Chapter 5 provides an assessment of current capabilities relative to future needs. Taking into account the system's total capacity relative to projected flows, it is estimated that approximately 20 MGD of additional treatment plant capacity is required for the 2050 planning horizon. Four conceptual options for conveyance and treatment have been formulated to manage these additional flows. These are:

- **CT 1 JWPCP Expansion:** All flows beyond the combined current treatment capacity of the existing WRPs would be directed to and treated at the JWPCP. This would require expansion of the JWPCP to accommodate system flow increases.
- **CT 2 WRP Expansion – Existing:** All flows beyond the current treatment capacity of the JWPCP would be intercepted by and treated at existing WRPs. This would require expansion to some of the WRPs to accommodate system flow increases.

- **CT 3 WRP Expansion – New:** All flows beyond the existing facilities' (WRPs and the JWPCP) combined current treatment capacity would be directed to and treated at a new WRP. System flow increases would be accommodated by the new WRP.
- **CT 4 WRP Expansion – Existing and New:** All flows beyond current capacity of the JWPCP would be intercepted by and treated at a combination of expanded existing WRPs and a new WRP.

Each of these conceptual options is described in the following subsections. For options that involve the expansion of existing facilities, consideration is given to increasing capacity by way of either conventional expansions or incorporating some degree of process optimization to existing process trains. For a new WRP, consideration is given to the potential application of new processes and technologies that differ from existing systems (process modifications).

CT 1 JWPCP Expansion

This option would utilize all of the WRPs up to their existing capacities for treatment of tributary flows, with all flows in excess of these combined capacities directed to and treated at the JWPCP. The JWPCP would be expanded as required, with no expansions of the existing WRPs undertaken. The JWPCP is a 400-MGD pure oxygen activated sludge wastewater treatment plant. No significant changes to current discharge requirements are anticipated. Taking into account the facility's current operational effectiveness and efficiency of treatment, consideration of either a new process or significant changes for process optimization are not warranted nor included in this option. As such, any future expansion at the JWPCP would be consistent with current processes and configurations.

This option would minimize the number of plants (i.e., limited to just one) affected by construction activities associated with treatment capacity expansion. It also may represent one of the lower unit cost approaches due to plant scale and level of treatment. However, this option would require the greatest level of conveyance system improvements to accommodate the transportation of flows to the JWPCP.

CT 2 WRP Expansion – Existing

This option would use the JWPCP up to its current treatment capabilities. Flow beyond this would be treated at the WRPs. The accommodation of these future flows would require capacity expansion of the WRPs. As stated in the Sanitation Districts' previous planning documents, including A Plan for Water Reuse (1963), the JOS Facilities Plan (1977), and the JOS 2010 Master Facilities Plan (1995), it is the general preference of the Sanitation Districts to expand upstream WRPs in lieu of major relief projects for the downstream conveyance system where practical. Large conveyance system projects can be very expensive and generate adverse environmental and community impacts during construction. The WRPs, on the other hand, provide substantial benefits in the form of increased water supplies by providing water recycling and reuse opportunities.

With six WRPs under consideration, a large number of potential WRP capacity expansion combinations that could be evaluated in connection with this option exist. The design of the WRPs is modular and, as such, any facilities expansion contemplated would follow the planned framework for plant expansion. For the Pomona Water Reclamation Plant (POWRP) and the Whittier Narrows Water Reclamation Plant (WNWRP), the modules are 5 MGD. For the San Jose Creek Water Reclamation Plant (SJCWRP), Los Coyotes Water Reclamation Plant (LCWRP), and Long Beach Water Reclamation Plant (LBWRP), the modules are 12.5 MGD. No additional flows are tributary to the La Cañada Water Reclamation Plant (LACAWRP) are projected, so no further evaluation of this plant is provided within this chapter.

Processes employed at the WRPs are primary sedimentation followed by fine-bubble, air activated sludge secondary treatment that includes nitrification and denitrification. Secondary treatment is followed by

tertiary filtration and disinfection. All solids and residuals are returned to the conveyance system for treatment at the downstream JWPCP. With this approach, the economies of scale associated with using the WRP facilities for expansion as originally planned would apply. Consistency with existing systems and the resulting familiarity with plant operations would also be provided.

For options that include expansion of the existing WRPs, consideration of process optimization is warranted. Process optimization consists of modifications within the existing plant to ensure that the Sanitation Districts continue to consistently meet permit conditions in anticipation of increasing regulatory requirements. While there are a variety of potential approaches to optimizing current treatment at the WRPs, such as treatment system modifications and other in-plant upgrades, the inclusion of flow equalization, or partial flow equalization, could provide the greatest number of potential benefits. With this approach, storage capacity is provided to attenuate peak plant flows and/or loadings. Flow equalization:

- Promotes conditions for consistent ammonia removal
- Accommodates influent ammonia concentration variations and spikes
- Balances diurnal flow variations and thereby maximizes reuse potential
- Reduces peak flows to the tertiary processes (filtration and disinfection)
- Potentially increases the amount of recycled water that can be produced and used during low influent flow conditions (i.e., which are typically at night, when landscape demands for recycled water are highest)

Flow equalization can be implemented at a variety of locations within the treatment process train. For this conceptual option, consideration is provided for the equalization of effluent from the primary sedimentation tanks. The Sanitation Districts have a positive track record with primary effluent equalization at other facilities outside the JOS (i.e., the Valencia and Saugus WRPs). This approach can improve the reliability and stability of downstream processes while retaining a reasonable level of system maintenance.

The volume of equalization storage provided varies depending on plant-specific requirements. In some cases, partial attenuation of the peak loading would be sufficient to provide stable and reliable process operation for systems such as secondary treatment. The other extreme is providing complete equalization of the entire influent flow to eliminate hydraulic peaking and thereby reduce both the hydraulic and organic peak loading to all downstream processes. For the JOS WRPs evaluated as part of this conceptual option, process optimization through flow equalization of the primary effluent for peak loading attenuation will be evaluated.

Facilities expansion would use the existing process train, with the addition of primary effluent flow equalization facilities, and follow the planned expansion module capacity (5 MGD at the POWRP and WNWRP, and 12.5 MGD at the SJCWRP, LCWRP, and LBWRP).

CT 3 WRP Expansion – New

This option would utilize the JWPCP and the existing WRPs up to their current capacities for treatment of tributary flows, with all flows in excess of this total combined capacity directed to and treated at a new WRP. Such an approach would provide the opportunity to:

- Accommodate flow increases resulting from population growth
- Relieve hydraulic constraints within the conveyance system

- Provide additional opportunities for reuse
- Reduce peak wet weather hydraulic loads to the JWPCP

Property considered as a site for a new WRP must comply with the following requirements:

- **Availability:** The land must be available for purchase, and there should not be any conflicting current uses of the property
- **Area:** There must be sufficient area available and the land configured in a geometry that would accommodate the needs of a WRP
- **Zoning:** The current zoning must be compatible with the intended use or zoning changes must be reasonably available
- **Access:** The property must have sufficient vehicular access to initially allow for construction activities and subsequently allow for plant operation access (e.g., employees, equipment, consumable deliveries)
- **Acceptability:** The location selected must be such that its use would not create significant public opposition from individuals or groups
- **Wastewater Source:** The site must have both the quality of wastewater and the quantity needed for the intended use
- **Effluent Management:** The site must have access to a suitable location for effluent disposal, typically a surface water discharge point
- **Reuse Potential:** The site must be located as close as reasonably possible to reuse opportunities

The treatment train employed by a new WRP could be similar to that used at the existing WRPs, or new processes and technologies that differ from existing systems could be considered. Application of a different process would be warranted if there are more stringent discharge/reuse regulations or site limitations associated with the new WRP. Any number of process modifications could be considered for a new WRP ranging from fixed film reactors to the use of pure oxygen secondary reactors. For the purposes of this MFP, membrane bioreactors (MBRs) were evaluated as a potential system for a new WRP.

The MBR process employs the suspended growth activated sludge treatment process with membrane filtration equipment. The membranes provide the critical solids/liquids separation normally accomplished with secondary clarifiers. The activated sludge system is operated with mixed liquor concentrations of approximately 5,000 to 10,000 milligrams per liter (mg/L). The membrane type can be either microfiltration or ultrafiltration. These membranes are usually configured as submerged units with suction applied to draw in liquid with solids remaining in the source tank. Coarse bubble air is used around the membranes for both mixing and scouring. The resultant effluent quality is typically superior to that from a conventional activated sludge system followed by tertiary filters. This approach would:

- Provide a more compact facility
- Produce very high quality effluent, with no need for tertiary filtration
- Generate an effluent that is suitable for direct feed to reverse osmosis systems if required by future reuse demands
- Lessen impacts from poor settling sludges and maintain higher mixed liquor suspended solids (MLSS) concentrations

At this stage in the planning process, no decision relative to the specific process train employed at a new WRP is required. The ultimate decision, should this be a component of the recommended plan, would be driven by a wide variety of factors such as effluent discharge limitations, reuse opportunities, site constraints, economics, operational considerations, and public acceptability.

CT 4 WRP Expansion – Existing and New

This option would utilize the JWPCP up to its current capacity. Flows beyond this would be treated by a combination of an expansion of the existing WRPs and a new WRP.

The actual division of flows between the existing WRPs and a new WRP would be influenced by a number of factors that would ultimately be incorporated into the development of specific options. The types of factors that would be considered may include maximizing the usage of existing facilities' capacities, minimizing conveyance system modifications and associated construction disruption, optimizing the availability of recycled water based on projected demands, lessening the potential for impacts on public use facilities, and impacting the fewest number of treatment plant sites with construction activities.

For this option, increasing the capacities of the WRPs would consider the incorporation of process optimization. Also, for this option, a new WRP would include consideration of new processes and technologies that differ from those at the existing WRPs (i.e., process modification).

6.2.2.2 Options Eliminated Through Level 1 Screening

Within the CT program component area, all of the options examined revolved around the expansion of WRP capacity. Of the four conceptual approaches to WRP expansion reviewed, three were eliminated on the basis of the considerations described in the following.

CT 1 JWPCP Expansion: This option provides a straightforward approach to increasing treatment capacity by the expansion of only one plant, the JWPCP. Implementation of this option, however, would result in the greatest requirement for additional conveyance system improvements along with the associated costs and related adverse community and environmental impacts during construction. This conceptual option is also in direct conflict with the Clearwater Program objective of accommodating emerging markets for recycled water reuse.

CT 3 WRP Expansion – New: This option would site a new facility to accommodate all system flow increases. The ability to locate an available site, obtain the support of the surrounding community, and procure the necessary permits to proceed with implementation remains questionable. In addition, the cost of a new facility and all associated development would be considerably higher than expansion of the existing WRPs. Potentially, there is land available at the JWPCP on which to construct a new WRP. However, the influent flows to the JWPCP are not reclaimable without utilizing a costly advanced level of treatment to reduce the high TDS levels.

CT 4 WRP Expansion – Existing and New: This option would result in the expansion of at least one of the existing WRPs to accommodate a portion of the system flow increases and the construction of a new WRP to accommodate the remaining flow increases. Although the new WRP would not need to accommodate the entire 20 MGD of increased flows, a smaller WRP would still be subject to the same concerns raised with respect to the CT 3 WRP Expansion – New option.

6.2.2.3 Preliminary Options

Of the four conceptual options evaluated, one remains. The preliminary option for conveyance and treatment is:

- **CT 2 WRP Expansion – Existing**

In the formulation of options involving the expansion of the existing WRPs, two potential constraints must be factored into the analysis. First, based on current property boundaries, each existing WRP has an associated site capacity that cannot be exceeded. There are no plans to extend any of the current sites through property acquisition. Second, the WRPs are limited to accepting only those flows tributary to that plant. In some cases, however, tributary flows can be adjusted by changing settings in upstream flow diversion structures such as stop logs or other conveyance system modifications. For the purposes of this analysis, tributary flows were estimated based on the current conveyance system configuration and settings. The site capacities and projected 2050 tributary flows for each JOS treatment plant are presented in Table 6-1.

Table 6-1. Projected 2050 Tributary Flows and Site Capacities (MGD)

	POWRP	SJCWRP	WNWRP	LCWRP	LBWRP	JWPCP	Total
Projected Tributary Flows	13	135	44	38	23	359	612
Estimated Plant Site Capacities	30	125	80	125	50	700	1110

Conveyance and treatment options were formulated and defined in terms of capacity expansions to meet projected future flows at different treatment plants within the JOS. Flows intercepted and treated at the WRPs upstream of the JWPCP can decrease the hydraulic loading to the trunk sewers downstream of these WRPs, and thereby reduce the requirements for conveyance system hydraulic improvement projects. The first step in developing a comparative assessment of CT options with respect to conveyance system impacts was to establish the definition of when a sewer pipe segment has reached or exceeded its capacity and requires some type of hydraulic relief. For the purposes of this analysis, a capacity limitation, or project need, was identified as those pipeline segments for which the depth of peak dry weather flow (d) within the pipe was projected to be equal to or greater than 90 percent of the pipeline's diameter (D) (i.e., $d/D \geq 0.9$) when conveying future flows.

The next step in conducting the conveyance system assessment was to create a baseline configuration. This baseline can then be used to develop quantifiable, comparative impacts for each of the CT options relative to the baseline. The baseline configuration represents the existing conveyance system plus those projects currently identified and expected to be implemented within the MFP planning horizon (i.e., by the year 2050). In the baseline configuration, the flows intercepted and treated at the different WRPs were limited to the existing plant capacities; all flows in excess of current WRP capacities would be diverted around the WRPs and ultimately be tributary and conveyed to the JWPCP. With respect to identifying conveyance system constraints, this represents a worst-case scenario. CT options that expand capacity at any existing WRP would provide some downstream conveyance system hydraulic relief compared to this baseline configuration.

The assessment of conveyance system capabilities and determination of capacity limitations, as defined by the d/D criterion for both the baseline configuration and CT options, was accomplished using the Sanitation Districts' static GIS conveyance system model. The application of this modeling tool permits the assessment of conveyance system capacity constraints based on a variety of flows and plant treatment capacities within the system. Using the previously defined baseline configuration and applying projected 2050 JOS flows, conveyance system potential capacity limitations are summarized in Table 6-2. The

table lists the total lengths of these capacity constraints by each of the JO trunk sewer lines. The JO trunk sewers were previously depicted on Figure 5-16, with those having identified capacity limitations highlighted in red based on the criterion and methodology described above.

Table 6-2. Baseline Model Versus 2050 Flow – Identified Potential Joint Outfall Trunk Sewer Capacity Limitations

Joint Outfall (JO) Trunk Sewers	Length (miles)						Total
	Dia ≤ 24"	Dia > 24" to 36"	Dia > 36" to 48"	Dia > 48" to 56"	Dia > 56" to 72"	Dia > 72"	
JO A ^a	0.4	1.5	2.4	1.6	5.1	0.1	11.1
JO B	2.4	1.1	0.3	4.6	7.1	< 0.1	15.5
JO C	0.3	0.1	0.0	0.0	0.1	0.0	0.5
JO D	0.0	< 0.1	< 0.1	1.0	< 0.1	0.0	1.0
JO E	0.5	0.6	0.1	0.1	0.0	0.0	1.3
JO F	< 0.1	0.1	0.9	0.1	2.5	0.0	3.6
JO G	0.0	0.3	0.6	< 0.1	0.0	0.0	0.9
JO H	0.2	2.4	1.6	2.0	3.3	0.2	9.7
JO J	0.1	0.0	0.0	0.0	< 0.1	0.0	0.1
Total	3.9	6.1	5.9	9.4	18.1	0.3	43.7

^a Joint Outfall A includes JOA-1A sewers.

Dia = diameter

A similar conveyance system capacity assessment was conducted for each CT preliminary option. For the purposes of this analysis, the conveyance system needs identified for each option were compared to the conveyance system needs identified for the baseline configuration.

In the initial formulation of CT preliminary option CT 2, all feasible combinations of JOS treatment plant expansions capable of providing at least 612 MGD of total system treatment capacity were systematically identified. The development of these potential treatment scenarios was based on the following:

- The treatment capacity per expansion module is 12.5 MGD for the SJCWRP, LCWRP, and LBWRP, and 5 MGD for the POWRP and WNWRP
- The POWRP tributary flow can be increased up to 24 MGD by upstream sewer diversions; therefore, the expansion capacity at the POWRP is limited to 25 MGD
- The LBWRP tributary flow can be increased to match its 50-MGD site capacity by some combination of upstream sewer diversions, new interceptors, and pumping station modifications

The results of this analysis are a total of 18 potential treatment scenarios, as depicted in Table 6-3.

Table 6-3. Potential Treatment Scenarios

Scenario	Treatment Plant Expansion (MGD)				
	POWRP	WNWRP	SJCWRP	LCWRP	LBWRP
1	-	20	-	-	-
2	5	15	-	-	-
3	10	10	-	-	-
4	-	10	12.5	-	-
5	5	5	12.5	-	-
6	10	-	12.5	-	-
7	-	10	-	12.5	-
8	5	5	-	12.5	-
9	10	-	-	12.5	-
10	-	10	-	-	12.5
11	5	5	-	-	12.5
12	10	-	-	-	12.5
13	-	-	25	-	-
14	-	-	12.5	12.5	-
15	-	-	12.5	-	12.5
16	-	-	-	25	-
17	-	-	-	12.5	12.5
18	-	-	-	-	25

A number of the depicted scenarios may not be practical in terms of identified constraints for existing treatment plants and the current conveyance system capabilities. In addition, some of the scenarios may not be consistent with the basic planning objectives outlined for the Clearwater Program. The planning objective of greatest relevance in the comparative assessment of treatment scenarios is to provide a wastewater treatment and effluent management program that accommodates and promotes emerging recycled water reuse and biosolids beneficial use opportunities.

With respect to reuse, the greatest projected demands for recycled water are associated with the SJCWRP. It is estimated that long-term demands for recycled water at the SJCWRP will exceed the plant's ultimate site capacity. Therefore, to achieve the maximum levels of water reuse consistent with the planning objectives, CT preliminary options examined were limited to those scenarios that included expansion at the SJCWRP. The seven practical and consistent CT preliminary options evaluated that provide a minimum of 20 MGD throughout the JOS are presented in Table 6-4. CT 2A-F represent the six sub-options for CT 2. Each of the CT preliminary options outlined in this table is discussed in the subsections that follow.

Table 6-4. CT Preliminary Options

Option Number	Number of WRPs Constructed/Expanded	Option Designation	Scenario From Table 6-3
CT 2A	1	SJC	13
CT 2B	3	SJC/PO/WN	5
CT 2C	2	SJC/PO	6
CT 2D	2	SJC/WN	4
CT 2E	2	SJC/LC	14
CT 2F	2	SJC/LB	15

Option CT 2A – SJC

In this option, the SJCWRP would be expanded by 25 MGD. This expansion would consist of the addition of two treatment modules. The plant capacities and associated expansions for this option are presented in Table 6-5.

Table 6-5. Option CT 2A – SJC: Modules and Flows

	POWRP	SJCWRP	WNWRP	LCWRP	LBWRP	JWPCP	Total
Existing Number of Modules	3	8	3	3	2	8	-
Number of New Modules Required	0	2	0	0	0	0	-
Total Number of Modules	3	10	3	3	2	8	-
Projected Plant Flows (MGD)	15	125	15	37.5	25	394.5	612

As shown in Table 6-5, the expansion would provide a total system capacity consistent with that required for the JOS in 2050. This approach would also provide additional high quality recycled water in areas of identified potential future demands. Option CT 2A would require the addition of multiple modules. It is likely that these would be staged over time based on flow increases experienced.

The conveyance system impacts have been analyzed using the static GIS conveyance system model and applying the previously described d/D criterion and evaluation methodology. The potential capacity limitations identified by this approach are listed in Table 6-6 by JO trunk sewers. For the purposes of comparison, the totals for the baseline configuration are also shown in Table 6-6.

Table 6-6. Option CT 2A – SJC: Identified Potential Joint Outfall Trunk Sewer Capacity Limitations

Joint Outfall (JO) Trunk Sewers	Length (miles)						Total
	Dia ≤ 24"	Dia > 24" to 36"	Dia > 36" to 48"	Dia > 48" to 56"	Dia > 56" to 72"	Dia > 72"	
JO A ^a	0.4	1.5	1.9	1.6	4.8	0.1	10.3
JO B	2.4	1.1	0.1	3.9	4.1	0.0	11.6
JO C	0.3	0.1	0.0	0.0	< 0.1	0.0	0.4
JO D	0.0	< 0.1	< 0.1	1.0	< 0.1	0.0	1.0
JO E	0.5	0.6	0.1	0.1	0.0	0.0	1.3
JO F	< 0.1	0.1	0.9	0.1	1.5	0.0	2.6
JO G	0.0	0.3	0.6	< 0.1	0.0	0.0	0.9
JO H	0.2	2.4	1.5	< 0.1	0.2	< 0.1	4.3
JO J	0.1	0.0	0.0	0.0	< 0.1	0.0	0.1
Total	3.9	6.1	5.1	6.7	10.6	0.1	32.5
Baseline Total	3.9	6.1	5.9	9.4	18.1	0.3	43.7
Difference	0.0	0.0	0.8	2.7	7.5	0.2	11.2

^a Joint Outfall A includes JOA-1A sewers.

Dia = diameter

Option CT 2B – SJC/PO/WN

In this option, the SJCWRP would be expanded by 12.5 MGD. This expansion would consist of the addition of one treatment module. The remaining required treatment capacity would be obtained by expanding both the POWRP and the WNWRP by 5 MGD. The POWRP would be expanded by one treatment module; the WNWRP would also be expanded by one treatment module. The plant capacities and associated expansions for this option are presented in Table 6-7.

Table 6-7. Option CT 2B – SJC/PO/WN: Modules and Flows

	POWRP	SJCWRP	WNWRP	LCWRP	LBWRP	JWPCP	Total
Existing Number of Modules	3	8	3	3	2	8	-
Number of New Modules Required	1	1	1	0	0	0	-
Total Number of Modules	4	9	4	3	2	8	-
Projected Plant Flows (MGD)	20	112.5	20	37.5	25	397	612

As shown in Table 6-7, the expansions would provide a total system capacity consistent with that required for the JOS in 2050. This approach would also provide additional high quality recycled water in areas of identified potential future demands. Option CT 2B would require the addition of multiple modules. It is likely these would be staged over time based on flow increases experienced.

The conveyance system impacts have been analyzed using the static GIS conveyance system model and applying the previously described criterion and methodology. The system potential capacity limitations identified by this approach are listed in Table 6-8 by JO trunk sewers. For the purposes of comparison, the totals for the baseline configuration are also shown in Table 6-8.

Table 6-8. Option CT 2B – SJC/PO/WN: Identified Potential Joint Outfall Trunk Sewer Capacity Limitations

Joint Outfall (JO) Trunk Sewers	Length (miles)						Total
	Dia ≤ 24"	Dia > 24" to 36"	Dia > 36" to 48"	Dia > 48" to 56"	Dia > 56" to 72"	Dia > 72"	
JO A ^a	0.4	1.0	1.9	1.6	4.8	0.1	9.8
JO B	2.4	1.1	0.1	4.0	4.6	0.0	12.2
JO C	0.3	0.1	0.0	0.0	0.1	0.0	0.5
JO D	0.0	< 0.1	< 0.1	1.0	< 0.1	0.0	1.0
JO E	0.5	0.6	0.1	0.1	0.0	0.0	1.3
JO F	< 0.1	0.1	0.9	0.1	1.5	0.0	2.6
JO G	0.0	0.3	0.6	< 0.1	0.0	0.0	0.9
JO H	0.2	2.4	1.5	0.4	0.7	< 0.1	5.2
JO J	0.1	0.0	0.0	0.0	< 0.1	0.0	0.1
Total	3.9	5.6	5.1	7.2	11.7	0.1	33.6
Baseline Total	3.9	6.1	5.9	9.4	18.1	0.3	43.7
Difference	0.0	0.5	0.8	2.2	6.4	0.2	10.1

^a Joint Outfall A includes JOA-1A sewers.

Dia = diameter

Option CT 2C – SJC/PO

In this option, the SJCWRP would be expanded by 12.5 MGD. This expansion would consist of the addition of one treatment module. The remaining required capacity would be obtained by a 10 MGD expansion of the POWRP. The POWRP would be expanded by the addition of two treatment modules. The plant capacities and associated expansions for this option are presented in Table 6-9.

Table 6-9. Option CT 2C – SJC/PO: Modules and Flows

	POWRP	SJCWRP	WNWRP	LCWRP	LBWRP	JWPCP	Total
Existing Number of Modules	3	8	3	3	2	8	-
Number of New Modules Required	2	1	0	0	0	0	-
Total Number of Modules	5	9	3	3	2	8	-
Projected Plant Flows (MGD)	25	112.5	15	37.5	25	397	612

As shown in Table 6-9, the expansions would provide a total system capacity consistent with that required for the JOS in 2050. This approach would also provide additional high quality recycled water in areas of identified potential future demands. Option CT 2C would require the addition of multiple modules. It is likely these would be staged over time based on flow increases experienced.

The conveyance system impacts have been analyzed using the static GIS conveyance system model and applying the previously described criterion and methodology. The system potential capacity limitations identified by this approach are listed in Table 6-10 by JO trunk sewers. For the purposes of comparison, the totals for the baseline configuration are also shown in Table 6-10.

Table 6-10. Option CT 2C – SJC/PO: Identified Potential Joint Outfall Trunk Sewer Capacity Limitations

Joint Outfall (JO) Trunk Sewers	Length (miles)						Total
	Dia ≤ 24"	Dia > 24" to 36"	Dia > 36" to 48"	Dia > 48" to 56"	Dia > 56" to 72"	Dia > 72"	
JO A ^a	0.4	0.9	1.9	1.6	4.8	0.1	9.7
JO B	2.4	1.1	0.1	4.3	4.6	0.0	12.5
JO C	0.3	0.1	0.0	0.0	0.1	0.0	0.5
JO D	0.0	< 0.1	< 0.1	1.0	< 0.1	0.0	1.0
JO E	0.5	0.6	0.1	0.1	0.0	0.0	1.3
JO F	< 0.1	0.1	0.9	0.1	1.5	0.0	2.6
JO G	0.0	0.3	0.6	< 0.1	0.0	0.0	0.9
JO H	0.2	2.4	1.5	0.3	0.4	< 0.1	4.8
JO J	0.1	0.0	0.0	0.0	< 0.1	0.0	0.1
Total	3.9	5.5	5.1	7.4	11.4	0.1	33.4
Baseline Total	3.9	6.1	5.9	9.4	18.1	0.3	43.7
Difference	0.0	0.6	0.8	2.0	6.7	0.2	10.3

^a Joint Outfall A includes JOA-1A sewers.

Dia = diameter

Option CT 2D – SJC/WN

In this option, the SJCWRP would be expanded by 12.5 MGD. This expansion would consist of the addition of one treatment module. The remaining required capacity would be obtained by a 10 MGD expansion of the WNWRP. The WNWRP would be expanded by the addition of two treatment modules. The plant capacities and associated expansions for this option are presented in Table 6-11.

Table 6-11. Option CT 2D – SJC/WN: Modules and Flows

	POWRP	SJCWRP	WNWRP	LCWRP	LBWRP	JWPCP	Total
Existing Number of Modules	3	8	3	3	2	8	-
Number of New Modules Required	0	1	2	0	0	0	-
Total Number of Modules	3	9	5	3	2	8	-
Projected Plant Flows (MGD)	15	112.5	25	37.5	25	397	612

As shown in Table 6-11, the expansions would provide a total system capacity consistent with that required for the JOS in 2050. This approach would also provide additional high quality recycled water in areas of identified potential future demands. Option CT 2D would require the addition of multiple modules. It is likely that these would be staged over time based on flow increases experienced.

The conveyance system impacts have been analyzed using the static GIS conveyance system model and applying the previously described criterion and methodology. The system potential capacity limitations identified by this approach are listed in Table 6-12 by JO trunk sewers. For the purposes of comparison, the totals for the baseline configuration are also shown in Table 6-12.

Table 6-12. Option CT 2D – SJC/WN: Identified Potential Joint Outfall Trunk Sewer Capacity Limitations

Joint Outfall (JO) Trunk Sewers	Length (miles)						Total
	Dia ≤ 24"	Dia > 24" to 36"	Dia > 36" to 48"	Dia > 48" to 56"	Dia > 56" to 72"	Dia > 72"	
JO A ^a	0.4	1.5	1.9	1.6	4.8	0.1	10.3
JO B	2.4	1.1	0.1	4.0	4.6	0.0	12.2
JO C	0.3	0.1	0.0	0.0	0.1	0.0	0.5
JO D	0.0	< 0.1	< 0.1	1.0	< 0.1	0.0	1.0
JO E	0.5	0.6	0.1	0.1	0.0	0.0	1.3
JO F	<0.1	0.1	0.9	0.1	1.5	0.0	2.6
JO G	0.0	0.3	0.6	< 0.1	0.0	0.0	0.9
JO H	0.2	2.4	1.5	1.8	0.9	< 0.1	6.8
JO J	0.1	0.0	0.0	0.0	< 0.1	0.0	0.1
Total	3.9	6.1	5.1	8.6	11.9	0.1	35.7
Baseline Total	3.9	6.1	5.9	9.4	18.1	0.3	43.7
Difference	0.0	0.0	0.8	0.8	6.2	0.2	8.0

^a Joint Outfall A includes JOA-1A sewers.

Dia = diameter

Option CT 2E – SJC/LC

In this option, the SJCWRP would be expanded by 12.5 MGD. This expansion would consist of the addition of one treatment module. The remaining required capacity would be obtained by a 12.5 MGD expansion of the LCWRP. The LCWRP would be expanded by the addition of one treatment module. The plant capacities and associated expansions for this option are presented in Table 6-13.

Table 6-13. Option CT 2E – SJC/LC: Modules and Flows

	POWRP	SJCWRP	WNWRP	LCWRP	LBWRP	JWPCP	Total
Existing Number of Modules	3	8	3	3	2	8	-
Number of New Modules Required	0	1	0	1	0	0	-
Total Number of Modules	3	9	3	4	2	8	-
Projected Plant Flows (MGD)	15	112.5	15	50	25	394.5	612

As shown in Table 6-13, the expansions would provide a total system capacity consistent with that required for the JOS in 2050. This approach would also provide additional high quality recycled water in areas of identified potential future demands. Option CT 2E would require the addition of multiple modules. It is likely these would be staged over time based on flow increases experienced and the optimal approach in terms of overall construction costs and facilities disruption.

The conveyance system impacts have been analyzed using the static GIS conveyance system model and applying the previously described criterion and methodology. The system potential capacity limitations identified by this approach are listed in Table 6-14 by JO trunk sewers. For the purposes of comparison, the totals for the baseline configuration are also shown in Table 6-14.

Table 6-14. Option CT 2E – SJC/LC: Identified Potential Joint Outfall Trunk Sewer Capacity Limitations

Joint Outfall (JO) Trunk Sewers	Length (miles)						Total
	Dia ≤ 24"	Dia > 24" to 36"	Dia > 36" to 48"	Dia > 48" to 56"	Dia > 56" to 72"	Dia > 72"	
JO A ^a	0.4	1.5	1.9	1.6	4.8	0.3	10.5
JO B	2.4	1.1	0.2	4.6	5.0	0.0	13.3
JO C	0.3	0.1	0.0	0.0	0.1	0.0	0.5
JO D	0.0	< 0.1	< 0.1	1.0	< 0.1	0.0	1.0
JO E	0.5	0.6	0.1	0.1	0.0	0.0	1.3
JO F	< 0.1	0.1	0.9	0.1	0.3	0.0	1.4
JO G	0.0	0.3	0.6	< 0.1	0.0	0.0	0.9
JO H	0.2	2.3	1.5	2.0	1.0	< 0.1	7.0
JO J	0.1	0.0	0.0	0.0	< 0.1	0.0	0.1
Total	3.9	6.0	5.2	9.4	11.2	0.3	36.0
Baseline Total	3.9	6.1	5.9	9.4	18.1	0.3	43.7
Difference	0.0	0.1	0.7	0.0	6.9	0.0	7.7

^a Joint Outfall A includes JOA-1A sewers.

Dia = diameter

Option CT 2F – SJC/LB

In this option, the SJCWRP would be expanded by 12.5 MGD. This expansion would consist of the addition of one treatment module. The remaining required capacity would be obtained by a 12.5 MGD expansion of the LBWRP. The LBWRP would be expanded by the addition of one treatment module. The plant capacities and associated expansions for this option are presented in Table 6-15.

Table 6-15. Option CT 2F – SJC/LB: Modules and Flows

	POWRP	SJCWRP	WNWRP	LCWRP	LBWRP	JWPCP	Total
Existing Number of Modules	3	8	3	3	2	8	-
Number of New Modules Required	0	1	0	0	1	0	-
Total Number of Modules	3	9	3	3	3	8	-
Projected Plant Flows (MGD)	15	112.5	15	37.5	37.5	394.5	612

As shown in Table 6-15, the expansions would provide a total system capacity consistent with that required for the JOS in 2050. This approach would also provide additional high quality recycled water in areas of identified potential future demands. Option CT 2F would require the addition of multiple modules. It is likely these would be staged over time based on flow increases experienced.

The conveyance system impacts have been analyzed using the static GIS conveyance system model and applying the previously described criterion and methodology. The system potential capacity limitations identified by this approach are listed in Table 6-16 by JO trunk sewers. For the purposes of comparison, the totals for the baseline configuration are also shown in Table 6-16.

Table 6-16. Option CT 2F – SJC/LB: Identified Potential Joint Outfall Trunk Sewer Capacity Limitations

Joint Outfall (JO) Trunk Sewers	Length (miles)						Total
	Dia ≤ 24"	Dia > 24" to 36"	Dia > 36" to 48"	Dia > 48" to 56"	Dia > 56" to 72"	Dia > 72"	
JO A ^a	0.5	1.5	1.9	1.6	4.8	0.1	10.4
JO B	2.4	1.1	0.2	4.6	5.0	0.0	13.3
JO C	0.3	0.1	2.7	0.0	0.1	0.0	3.2
JO D	0.0	< 0.1	< 0.1	1.0	< 0.1	0.0	1.0
JO E	0.5	0.6	0.1	0.1	0.0	0.0	1.3
JO F	< 0.1	0.1	0.4	0.0	0.8	0.0	1.3
JO G	0.0	0.3	0.6	< 0.1	0.0	0.0	0.9
JO H	0.2	2.4	1.5	2.0	1.0	< 0.1	7.1
JO J	0.1	0.0	0.0	0.0	< 0.1	0.0	0.1
Total	4.0	6.1	7.4	9.3	11.7	0.1	38.6
Baseline Total	3.9	6.1	5.9	9.4	18.1	0.3	43.7
Difference	-0.1	0.0	-1.5	0.1	6.4	0.2	5.1

^a Joint Outfall A includes JOA-1A sewers.

Dia = diameter

In addition to the capacity limitation within existing trunk sewers presented in Table 6-16, in order to obtain sufficient influent flows as the LBWRP consistent with the option, an additional interceptor would be required. This interceptor would be approximately 5 miles in length and 42 inches in diameter. Flows would be diverted from the area currently tributary to the LCWRP to the tributary area for the LBWRP.

CT Options Summary

A total of six CT preliminary options have been formulated and presented. These options represent a wide range of alternatives relative to distribution of flows to the different treatment plants and the associated facilities expansion resulting from increased tributary plant flows. A summary of treatment plants and projected flows in 2050 for each of the options identified is presented in Table 6-17. In addition to the expansions identified, all of the options include process optimization at the SJCWRP, POWRP, LCWRP, and LBWRP.

Table 6-17. Preliminary CT Options Summary

Preliminary Options	Projected Treatment Plant Flows (MGD)						Total
	POWRP	SJCWRP	WNWRP	LCWRP	LBWRP	JWPCP	
CT 2A SJC	15	125	15	37.5	25	394.5	612
CT 2B SJC/PO/WN	20	112.5	20	37.5	25	397	612
CT 2C SJC/PO	25	112.5	15	37.5	25	397	612
CT 2D SJC/WN	15	112.5	25	37.5	25	397	612
CT 2E SJC/LC	15	112.5	15	50	25	394.5	612
CT 2F SJC/LB	15	112.5	15	37.5	37.5	394.5	612

6.2.2.4 Level 2 Screening

The Level 2 screening parameters for the CT program component area are:

- Conveyance system impacts
- Treatment plant impacts
- Regulatory compliance
- Public acceptability
- Operational flexibility, reliability, and familiarity
- Cost effectiveness

The application of the Level 2 screening parameters is shown in Table 6-18.

Table 6-18. Comparison of Preliminary CT Options to Level 2 Screening Parameters

	Conveyance System Impacts	Treatment Plant Impacts	Regulatory Compliance	Public Acceptability	Operational Flexibility, Reliability, and Familiarity	Cost Effectiveness	Score	Ranking
CT 2A SJC	+	+	0	0	0	+	+3	1
CT 2B SJC/PO/WN	+	-	0	0	0	0	0	3
CT 2C SJC/PO	+	0	0	0	0	0	+1	2
CT 2D SJC/WN	+	0	0	0	0	0	+1	2
CT 2E SJC/LC	0	0	0	0	0	+	+1	2
CT 2F SJC/LB	-	0	0	-	0	-	-3	4

6.2.2.5 Options Eliminated Through Level 2 Screening

All of the options examined revolved around increasing total WRP capacity by expansion of existing plants. Of the six preliminary options put forth for consideration to expand the WRPs, the one option with a negative score was eliminated from further consideration:

CT 2F SJC/LB: The considerations that contributed to this scoring/ranking were:

- **Conveyance System Impacts:** This option would require the construction of approximately 5 miles of new major interceptor line. This would be in addition to the baseline conveyance system improvements that would be common to all options.
- **Public Acceptability:** The construction of this interceptor would create significant disruption in public rights-of-way and would be unfavorably viewed by those parties directly affected during construction.
- **Cost Effectiveness:** While all of the options under consideration would involve the construction of additional treatment capacity, the eliminated option is the only one that would require a significant additional investment in conveyance system infrastructure.

6.2.2.6 Viable Options

Of the six preliminary options evaluated, five remain. The viable options for conveyance and treatment are:

- **CT 2A SJC**
- **CT 2B SJC/PO/WN**
- **CT 2C SJC/PO**
- **CT 2D SJC/WN**
- **CT 2E SJC/LC**

6.2.2.7 Level 3 Screening

The viable options were evaluated in terms of compliance with Level 3 screening parameters to develop a set of ranked feasible options.

Level 3 Screening Parameters

Screening parameters were selected and defined to provide measurable, comprehensive, and independent results. Each option was scored on a system from zero (worst) to ten (best). Each of these parameters is briefly discussed in the paragraphs that follow.

Environmental Impacts

Environmental impacts consider both the short-term (construction) and long-term (operational) impacts related to the subject alternative. This parameter takes into account both the extent of construction as well as the sensitivity of areas affected. Long-term impacts also include any potential benefits related to water quality or resource use derived from facilities operation. The scores for this parameter range from zero, for a high degree of impacts and a high level of mitigation required, to ten, for limited impacts and no mitigation required.

Public Acceptability/Institutional Feasibility

The public acceptability/institutional feasibility parameter considers the relative degree of public acceptance anticipated for each of the alternatives. This includes views of individuals as well as community groups. Inasmuch as public institutions represent the interests and views expressed by elected officials, the support of these institutions is factored into the analysis. The need for, and the ability to, procure permits and approvals from other agencies are also incorporated into this parameter. The scores for this parameter range from zero, for a high degree of public opposition and extensive permits and approvals, to ten, for positive public perceptions and support and no outside permits or approvals needed.

Operational Considerations

Operational considerations assess the impact of new facilities on current plant O&M. The assessment includes examination of impacts on operational flexibility, plant reliability, and the operations staffs' current familiarity with treatment systems under consideration. The ability to consistently meet all discharge requirements is also included within this parameter. The scores for this parameter range from zero, for limited experience with systems under consideration, to ten, for a high degree of flexibility, reliability, and familiarity.

Promote Reclamation/Reuse

Promote reclamation/reuse considers the potential for increased recycling and reuse of plant effluent over the planning period. This is affected by the location of effluent generation (which WRPs are expanded) as well as the projected future reuse demands that may exist in a particular area within a reasonable proximity of the plant. The scores for this parameter range from zero, for least reuse potential, to ten, for greatest reuse potential.

Cost Effectiveness

Cost effectiveness considers the capital costs associated with the implementation of each alternative. The capital costs are divided into three major component costs: conveyance improvements, process optimization, and treatment plant expansions. The scores for this parameter range were based on the ratio of that option's cost against the lowest cost alternative, with the lowest cost alternative receiving a ten.

The scores for the parameters were then weighted according to the values in Table 6-19 and combined to determine a weighted score for each option. The evaluation and screening process employed a multi-criteria decision support software tool to facilitate the overall assessment effort. The software provided the flexibility to investigate a wide range of evaluation approaches and allowed for a sensitivity analysis of outcomes.

Table 6-19. Level 3 Screening Parameters and Weighting

Parameter	Weight (Percent)
Environmental Impacts	25
Public Acceptability/Institutional Feasibility	20
Operational Considerations	15
Promote Reclamation/Reuse	20
Cost Effectiveness	20

The scoring summary of the viable options, including the relative rankings, is presented in Table 6-20.

Table 6-20. Viable Options Scoring Summary

Option	Weighted Score	Relative Ranking
CT 2A SJC	9.25	1
CT 2B SJC/PO/WN	6.45	4
CT 2C SJC/PO	8.40	2
CT 2D SJC/WN	6.25	5
CT 2E SJC/LC	7.95	3

6.2.2.8 Viable Options Eliminated

On the basis of the assessment of viable options and the application of Level 3 screening parameters, four of the five viable options were eliminated from further consideration. Option CT 2A SJC scored the

highest in all five of the screening parameters and had the highest weighted score. Therefore, it will be carried forward as the only feasible option. The factors contributing to the elimination of the other options are discussed in the following paragraphs.

CT 2B SJC/PO/WN: This option has a significant potential for environmental impacts. These impacts are related to the construction at the WNWRP within a flood plain area and adjacent to a possible wetland habitat composed of riparian scrub. Expansion of the WNWRP would also likely require a fairly extensive effort with respect to permitting and obtaining approval from the U.S. Army Corps of Engineers (Corps) for modification of the flood plain site. The complexity of construction in a flood plain also results in relatively high capital costs. This option also requires construction and would result in impacts at three separate treatment plant sites.

CT 2C SJC/PO: This option has additional environmental impacts related to a slightly longer length of conveyance improvements than the recommended option and construction and resulting impacts at two separate treatment plant sites. This option results in higher capital costs.

CT 2D SJC/WN: This option has a significant potential for environmental impacts. These impacts are related to the construction at the WNWRP within a flood plain area and adjacent to a possible wetland habitat composed of riparian scrub. Expansion of the WNWRP would also likely require a fairly extensive effort with respect to permitting and obtaining approval from the Corps for modification of the flood plain site. The complexity of construction in a flood plain also results in relatively high capital costs. This option also requires construction and would result in impacts at two separate treatment plant sites.

CT 2E SJC/LC: This option has additional environmental impacts related to a longer length of conveyance improvements than the recommended option, impacts on recreational areas, and construction and resulting impacts at two separate treatment plant sites. There is greater reuse potential with the recommended option. This option also results in higher capital costs.

6.2.2.9 Ranked Feasible Options

Of the five viable options evaluated, one remains. The only feasible, thus top-ranked, option for conveyance and treatment is:

- CT 2A SJC

6.2.3 Solids Processing (SP)

6.2.3.1 Conceptual Options

The primary objective of the solids processing systems is to convert the treatment process residuals from a liquid sludge to a more stable, substantial material that is termed *biosolids*. Processes employed in connection with this conversion include thickening, stabilization, and dewatering. All solids from the WRPs and the JWPCP are currently treated at the JWPCP.

SP 1 Centralized Processing at the JWPCP

This option would continue the existing practice of treating all solids at the JWPCP. Solids generated at the upstream WRPs would continue to be returned to the conveyance system and removed and treated at the JWPCP. Any new facilities for solids processing required in terms of level of treatment or expansion of capacity would be implemented at the JWPCP. Such an approach provides continuity with existing practice and avoidance of major investments in new systems and/or property acquisition.

SP 2 Processing at Source Plants

In this option, the solids processing would take place at the plants where the materials are generated. This would result in solids processing systems at each of the WRPs; the systems at the JWPCP would remain in place but would operate at a lower capacity reflecting the reduced loading. This approach would increase conveyance capacity for raw wastewater by removing the solids currently returned to the system and eliminate the double removal (first at the WRPs and then at the JWPCP) of these materials within the treatment systems. The land used for solids processing facilities at the WRPs would not be available for additional wastewater treatment facilities.

SP 3 Centralized Processing – New Sites

In this option, all solids from the WRPs would be returned to the JOS conveyance system and ultimately removed at the JWPCP. The subsequent processing of these materials, however, would take place at a new site, remote from the existing facility. All solids generated would be collected, pumped, and conveyed to the new site via a dedicated sludge pipeline. Systems employed for processing would be the same as currently used. This option would reduce potential impacts associated with solids processing to the community immediately surrounding the JWPCP. These community impacts, however, would essentially be transferred to the area surrounding the new solids processing site. The removal of this function from the existing plant would also free these areas for alternative uses.

6.2.3.2 Options Eliminated Through Level 1 Screening

Three solids processing conceptual options were examined. Of these, the following two options were eliminated from further consideration:

SP 2 Processing at Source Plants: A number of significant limitations exist relative to consideration of processing solids at the WRPs. Many of these sites are space-limited and could not accommodate the areas required for solids processing within their current footprint. If the Sanitation Districts sought to acquire additional adjacent land for plant expansion, significant opposition to such an arrangement could be anticipated from nearby property owners. As a result, the ability to procure required permits, as well as obtain environmental clearances for implementation, is likely to be significantly challenged. If the solids processing facilities were implemented within the WRPs' current footprints, it would significantly reduce the availability of property for water recycling facilities. This would, in turn, effectively reduce plant capacity and, thereby, not accommodate future recycled water reuse opportunities. The costs of duplicating existing systems would be considerable, limiting the relative cost effectiveness of such an arrangement.

SP 3 Centralized Processing – New Site: The primary limitations associated with this option are similar to those cited for Option SP 2. Finding a suitable location where there would not be significant community opposition is unlikely. As a result, the ability to procure the required permits, as well as obtain environmental clearances for implementation, is questionable. The costs of duplicating existing systems would be considerable, and, therefore, this approach does not provide a cost-effective means of solids management.

6.2.3.3 Preliminary Options

Of the three conceptual options evaluated, one remains. The only preliminary option for solids processing is:

- **SP 1 Centralized Processing at the JWPCP**

This option represents continuation of existing practices. Within the context of this preliminary option, the existing processes for thickening, stabilization, and dewatering will be examined to determine if they represent the most appropriate technologies for the future, or if changes are warranted. Sub-options representing further elaboration of this concept are discussed in the subsections that follow. While both options involve processing solids at the JWPCP, the systems employed would be different.

SP 1A Continue Existing Solids Processing Systems

The existing systems at the JWPCP for solids processing are:

- Waste Activated Sludge (WAS) Thickening: Dissolved air flotation (DAF) thickeners
- Stabilization: Conventional anaerobic digesters
- Dewatering: Centrifuges

These systems would continue to be employed and, as flows and loads to the JWPCP increase, these processes would be expanded to keep pace with capacity needs. Such an approach provides continuity with existing practices and avoids major investment in new systems.

SP 1B New Solids Processing Systems

In this option, the existing solids processing systems would be replaced with new systems.

There are a large number of WAS thickening systems available that are different from the existing DAFs. The two most likely to be found in plants of this type are gravity belt thickeners (GBTs) and centrifuge thickeners. The GBTs represent possibly the simplest and lowest energy type of approach, but have high polymer consumption, and a higher potential for odor generation. Centrifuge thickeners are more common at larger plants like the JWPCP and would be consistent with equipment used in the dewatering process. Centrifuge thickeners permit a more positive approach to air emission containment and odor control, but typically have the highest power consumption among thickening processes.

While there are a large number of possible approaches to sludge stabilization, anaerobic digestion is used at most large facilities for this purpose. One variation on the process is to modify the reactor type from a conventional cylindrical digester to an egg-shaped digester. Egg-shaped digesters are more efficient in terms of space requirements and typically have less frequent requirements for routine removal from service for cleaning. These units are typically more expensive to construct.

Other than centrifuge dewatering, two other systems used at larger plants are belt presses and filter presses. Belt presses, while used at some large plants, are typically not employed for plants of the size of the JWPCP due to the large number of individual units that would be required. Filter presses can provide a high solids sludge cake product typically using lime and metallic salts for conditioning in lieu of polymer.

6.2.3.4 Level 2 Screening

The screening parameters for the SP program component area are:

- Treatment plant impacts
- Institutional feasibility
- Regulatory compliance
- Public acceptability

- Operational flexibility, reliability, and familiarity
- Cost effectiveness

The application of the Level 2 Screening Parameters is shown in Table 6-21.

Table 6-21. Comparison of Preliminary Options to Level 2 Screening Parameters

	Treatment Plant Impacts	Institutional Feasibility	Regulatory Compliance	Public Acceptability	Operational Flexibility, Reliability, and Familiarity	Cost Effectiveness	Score	Ranking
SP 1A JWPCP: Existing Systems	0	0	0	0	+	+	+2	1
SP 1B JWPCP: New Systems	-	0	0	0	-	-	-3	2

6.2.3.5 Options Eliminated Through Level 2 Screening

One sub-option was eliminated from consideration through Level 2 screening:

SP 1B New Solids Processing Systems: This option was eliminated on the basis of:

- **Treatment Plant Impacts:** The implementation of significant new facilities at the JWPCP would result in significant construction-related disruption to the plant's operations for a significant duration.
- **Operational Flexibility, Reliability, and Familiarity:** The new systems under consideration represent a significant departure from the technology currently employed without commensurate improvement in efficiency or effectiveness.
- **Cost Effectiveness:** The replacement of existing systems with alternate technologies represents a significant expenditure. This investment would not yield a commensurate improvement in efficiency or effectiveness.

In summary, the systems and processes currently in place represent appropriate and sound technologies for the applications in question. Any significant changes would detrimentally impact operations based on the current level of system familiarity. Finally, the costs and complexity of process changes would be prohibitive without providing any resulting substantive, offsetting benefits.

6.2.3.6 Viable Options

Of the two sub-options examined under the preliminary option SP 1 Centralized Processing at the JWPCP, one remains. The only viable option for solids processing is:

- **SP 1A Continue Use of Existing Solids Processing Systems**

This option represents a continuation of the current systems and practices for solids processing.

6.2.3.7 Level 3 Screening

Only one viable option remains, so it is not subject to any further screening.

6.2.3.8 Viable Options Eliminated

No viable options were eliminated.

6.2.3.9 Ranked Feasible Options

The only feasible, thus top-ranked, option for solids processing is:

- **SP 1A Continue Use of Existing Solids Processing Systems**

6.2.4 Biosolids Management (BM)

6.2.4.1 Conceptual Options

The primary objective of biosolids management is to effectively and efficiently dispose of, or beneficially use, all the biosolids generated by wastewater treatment within the JOS. The current practice relies on a diversified program of beneficial biosolids use and landfill disposal. The conceptual options identify alternatives including, and in addition to, the current practice.

BM 1 Current Practice – Beneficial Use/Landfill

The current practice is to maximize the beneficial use of biosolids, while maintaining the ability to use landfilling. Under this option, the current practice would continue into the future.

BM 2 Landfill Disposal – All Biosolids

In this option, all biosolids would be disposed of in landfills. This approach could potentially simplify the administration and management of the biosolids use/disposal program. As the owner and operator of the landfill, the Sanitation Districts would have complete oversight and responsibility for biosolids disposal independent of any third parties.

BM 3 Beneficial Use – All Biosolids

In this option, all biosolids would be beneficially used. There would be no provisions for use of a landfill for biosolids disposal. As a result, the number and diversity of beneficial uses would have to be such that there is sufficient beneficial use capacity under a variety of future scenarios without any potential for interruption of service. This would result in a high degree of dependency on third parties to assure adequate beneficial use options.

6.2.4.2 Options Eliminated Through Level 1 Screening

Of the three conceptual options considered, one option was eliminated.

BM 2 Landfill Disposal – All Biosolids: This option would preclude any beneficial use of biosolids. It is inconsistent with the objective of accommodating current and emerging biosolids recycling and beneficial use opportunities. It is also likely that such an arrangement would be unfavorably received by the public. It may also be inconsistent with regulations aimed at reducing the volume of materials going into sanitary landfills. Finally, it does not take into consideration that the Puente Hill Landfill is scheduled to close in 2013. Consequently, it was eliminated from further consideration.

6.2.4.3 Preliminary Options

Of the three conceptual options reviewed, two options remain. The preliminary options for biosolids management are:

- **BM 1 Current Practice – Beneficial Use/Landfill**
- **BM 3 Beneficial Use – All Biosolids**

Each of these is briefly described in the sections that follow.

BM 1 Current Practice – Beneficial Use/Landfill

This option entails the continuation of a diversified program of biosolids management practices, including beneficial uses, that enhances the environment, provides a reliable means of ultimate disposition of the biosolids, is cost-effective, and complies with all regulatory requirements.

The majority of current beneficial biosolids uses involve agriculture. These include:

- Land application of Class B biosolids cake
- Lime stabilization and land application
- Composting and land application
- Composting and production of soil amendment products

The Sanitation Districts are currently in the process of implementing the first phase of a state-of-the-art composting facility called Westlake Farms, which is scheduled to begin operations in 2013. This will provide an additional degree of reliability relative to biosolids beneficial use beyond what currently exists.

Landfill co-disposal with municipal solid waste would likely be curtailed given that the Puente Hills Landfill is scheduled for closure in 2013.

BM 3 Beneficial Use – All Biosolids

In this option, all biosolids would be beneficially used. There would be no provisions for use of a landfill for biosolids co-disposal. As a result, the number and diversity of beneficial uses would have to be such that there is sufficient beneficial use capacity under a variety of future scenarios without any potential for interruption of service.

A number of challenges exist in regard to service reliability. Third parties operate many of the current beneficial use sites. While the Sanitation Districts have contractual agreements with these parties, the potential exists that one or more of these parties could default on their obligations to accept and beneficially use biosolids. The locations of these beneficial use operations tend to be in remote areas located at a significant distance from the site of biosolids generation, the JWPCP. Weather or other circumstances that interfere with biosolids transport could disrupt planned beneficial use options.

6.2.4.4 Level 2 Screening

The screening parameters for the BM program component area are:

- Resource reuse
- Sustainability

- Regulatory compliance
- Public acceptability
- Operational flexibility and reliability
- Cost effectiveness

The application of the Level 2 Screening Parameters is shown in Table 6-22.

Table 6-22. Comparison of Preliminary Options to Level 2 Screening Parameters

	Resource Reuse	Sustainability	Regulatory Compliance	Public Acceptability	Operational Flexibility and Reliability	Cost Effectiveness	Score	Ranking
BM 1 Current Practice – Beneficial Use/Landfill	+	+	0	+	+	0	+4	1
BM 3 Beneficial Use – All Solids	+	+	0	+	-	0	+2	2

6.2.4.5 Options Eliminated Through Level 2 Screening

Of the two Preliminary Options developed for biosolids management, one is eliminated from further consideration:

BM 3 Beneficial Use – All Solids: This alternative is virtually identical to the other remaining option, BM 1 Current Practice – Beneficial Use/Landfill, except that BM 3 lacks the ability to utilize a landfill. This lack of diversity substantively impacts the screening criterion of operational reliability. On this basis, this option was eliminated.

6.2.4.6 Viable Options

Of the two preliminary options evaluated, one remains. The only viable option for biosolids management is:

- **BM 1 Current Practice – Beneficial Use/Landfill**

This option represents the continuation of current practices, which emphasize the beneficial uses of biosolids, while maintaining the ability to use landfilling.

6.2.4.7 Level 3 Screening

Only one viable option remains, so it is not subject to any further screening.

6.2.4.8 Viable Options Eliminated

No viable options were eliminated.

6.2.4.9 Ranked Feasible Options

The only feasible, thus top-ranked, option for biosolids management is:

- **BM 1 Current Practice – Beneficial Use/Landfill**

6.2.5 WRP Effluent Management (WE)

6.2.5.1 Conceptual Options

The primary objective of WRP effluent management is to identify outlets for the recycled water produced at the WRPs. The systems must be:

- **Reliable:** Able to consistently manage effluent from all flows generated
- **Compliant:** Achieve all pertinent regulatory requirements

In addition to these characteristics, the effluent management approaches considered as options should be able to accommodate future flow increases tributary to a facility, enhance the environment, and foster resource reuse.

The LACAWRP effluent management system is self-contained (i.e., all effluent is reused for irrigation) and, therefore, is not reviewed further. The remaining five WRPs' primary means of effluent management consists of regulated, surface water discharges to the San Gabriel River or its tributaries. In addition, all plants provide effluent for beneficial reuse. The level of reuse fluctuates based on demand, which can vary depending on the WRP, the time of day, and the time of year.

WE 1 Current Effluent Management Systems

This conceptual option represents a continuation of the current practices for effluent management, which include a combination of surface water discharge and reuse. No major changes to either the discharge locations or protocols employed are included within this option.

WE 2 All Reuse – No Surface Water Discharge

In this conceptual option, all surface water discharges from the WRPs would be eliminated. This would entail significantly increased levels of water recycling, with emphasis on approaches that are not weather dependent. This option would include evaluating the potential for water recycling associated with:

- Landscape irrigation
- Agricultural irrigation
- Industrial processes (e.g., cooling water)
- Recreational impoundments
- Groundwater recharge – spreading
- Groundwater recharge – injection
- Seawater barrier creation – injection

The highest WRP flows correspond with wet weather events. During these conditions, a number of the reuse alternatives are not available to accept flows. The reclamation alternatives not affected by wet weather events, in many cases, are likely to require higher levels of treatment at the WRPs, as well as additional facilities for treated effluent storage, conveyance, and reuse.

WE 3 All Surface Water Discharge – No Reuse

In this conceptual option, all current reuse of WRP effluent would be discontinued at the earliest feasible date. This would require the renegotiation of current agreements and eliminating from consideration any future arrangements to reuse WRP effluent. All effluent disposal would take place using current, approved surface water discharge locations.

6.2.5.2 Options Eliminated Through Level 1 Screening

Three conceptual options for management of the effluent from the WRPs were reviewed. Of these, the following two approaches were eliminated from further consideration.

WE 2 All Reuse – No Surface Water Discharge: This option would require the reclamation and reuse of all WRP effluent. The recycled water demand to permit acceptance of all effluent during the full range of seasonal events (e.g., extended wet weather periods) does not exist, and, therefore, would not provide for a reliable means of effluent management. Without adequate management capabilities, the system capacity to meet the needs of the growing JOS population could not be achieved. The Sanitation Districts are also dependent on the parties reusing the recycled water and the water retailers to develop reuse opportunities. Despite over four decades of aggressively marketing recycled water, over half of the recycled water produced is not reused and is discharged to receiving waters. Therefore, planning for complete reuse of all WRP effluent is not practicable or responsible. The costs for additional treatment, as well as conveyance, could also decrease the relative cost effectiveness of this approach. Elimination of this option does not preclude continued growth of the existing, robust program of recycling and reuse within the JOS.

WE 3 All Surface Water Discharge – No Reuse: This option would require the termination of all existing agreements to provide recycled water. In addition, no action would be taken to capitalize on future recycled water reuse opportunities. The feasibility of doing so, and associated legal ramifications, would need to be carefully evaluated. This approach would also contradict the Sanitation Districts' current policies, as well as those of the state of California, relative to water recycling and reuse. It would not accommodate emerging reuse opportunities. In a water-limited region such as Southern California, the public would consider any type of exclusion of reuse and recycling as wasting a potentially valuable resource. Associated negative publicity and political impacts could detrimentally affect the Sanitation Districts as well.

6.2.5.3 Preliminary Options

Of the three conceptual options examined, one remains. The only preliminary option for WRP effluent management is:

- **WE 1 Current Effluent Management System**

This approach is consistent with the Clearwater Program goal and objectives. This option entails the continuation of existing practices that incorporate a combination of surface water discharge and reuse. While the amount of effluent managed and/or consumed by reuse is likely to increase in the future, surface water discharge capabilities would be retained. The ability to discharge to surface waters provides necessary flexibility in managing the effluent. Many of the current and future reuse opportunities may involve third parties and associated facilities and contractual agreements. The Sanitation Districts have limited control of third parties.

6.2.5.4 Level 2 Screening

Only one preliminary option remains, so it is not subject to any further screening.

6.2.5.5 Options Eliminated Through Level 2 Screening

No options were eliminated through Level 2 Screening.

6.2.5.6 Viable Options

The only viable option for WRP effluent management is:

- **WE 1 Current Effluent Management System**

6.2.5.7 Level 3 Screening

Only one viable option remains, so it is not subject to any further screening.

6.2.5.8 Viable Options Eliminated

No viable options were eliminated.

6.2.5.9 Ranked Feasible Options

The only feasible, thus top-ranked, option for WRP effluent management is:

- **WE 1 Current Effluent Management System**

6.2.6 JWPCP Effluent Management (JE)

6.2.6.1 Conceptual Options

The primary objective of the JWPCP effluent management system is to provide outlets for the wastewater treated at the JWPCP. The systems must be:

- **Reliable:** Able to consistently manage all effluent flows, including peak storm flows
- **Compliant:** Achieve all pertinent regulatory requirements

In addition, the effluent management approaches considered as options should be able to accommodate future flow increases and reuse at the JWPCP.

Currently, JWPCP-treated effluent is managed entirely by means of ocean discharge; no reuse of JWPCP effluent currently takes place. Two approximately 6-mile long onshore tunnels convey effluent from the plant to a manifold structure located beneath Sanitation Districts-owned property at Royal Palms Beach, located near White Point on the Palos Verdes Peninsula. The 8-foot diameter tunnel was constructed in 1937, and the 12-foot diameter tunnel was constructed in 1958. Neither of the tunnels has been inspected in over 50 years. Inspection of the tunnels is not possible due to their overall length, limited access, lack of hydraulic separation between the tunnels, and the large quantity of daily effluent flow through the tunnels. For the same reasons, repair and rehabilitation of these tunnels, should it be warranted, is not possible. Furthermore, both tunnels cross an active seismic fault (the Palos Verdes Fault), but neither was constructed to modern day seismic standards and neither have been retrofitted since being built.

From the manifold, effluent flows can be distributed between four ocean outfalls with diameters of 60, 72, 90, and 120 inches that were constructed in 1937, 1947, 1957, and 1966, respectively. The 90- and 120-inch outfalls are used daily, and the 60- and 72-inch lines serve as backups. The 90- and 120-inch outfalls extend approximately one and a half miles offshore to a depth of about 200 feet below sea level. All four ocean outfalls consist of reinforced concrete pipelines constructed on the seafloor with a series of ports (diffusers) at their discharge depths. Unlike the tunnels, there is access to the ocean outfalls for detailed inspection and, if needed, repair and rehabilitation.

JE 1 Existing Ocean Discharge System

In this conceptual option, the existing tunnel and ocean outfall system would be used. There would be no major changes to the facilities or their mode of operation, but the existing ocean outfalls would require rehabilitation. With such an approach, there is very limited activity required and as a result, little in the way of cost and permitting associated with this option's implementation. However, the integrity of the two existing onshore tunnels cannot be verified, and the risk of failure of this critical infrastructure link is not abated with this option.

JE 2 New Ocean Discharge System

In this conceptual option, a new ocean discharge system – comprising an onshore tunnel, an offshore tunnel or seafloor pipeline, and a diffuser – would be constructed. The new system would have the capacity to accommodate all current and projected future flows. This option provides redundancy to critical aging infrastructure (the two existing onshore tunnels and four ocean outfalls), thereby increasing overall system reliability. Any new system would have its diffuser located in an area that would meet or exceed the performance of the existing diffusers with respect to environmental protection and public safety. Construction of this option would allow the existing tunnels to be inspected and repaired as necessary. This option would also include rehabilitation of the existing ocean outfalls.

JE 3 Modified Ocean Discharge System

In this conceptual option, a new onshore tunnel would be constructed between the JWPCP and the existing manifold structure at Royal Palms Beach. The new tunnel would tie into the existing outfalls. Once connected, the modified ocean discharge system would have the capacity to accommodate all current and projected future flows. This option provides redundancy to critical aging infrastructure (the two existing onshore tunnels), thereby increasing overall system reliability. Construction of this option would allow the existing tunnels to be inspected and repaired as necessary. This option would also include rehabilitation of the existing ocean outfalls.

JE 4 Reduced Ocean Discharge

In this conceptual option, flows to the existing ocean discharge would be substantially reduced. Advanced treatment facilities would be constructed at the JWPCP, and the advanced-treated effluent would be diverted for indirect potable reuse via groundwater recharge. The reduction in ocean discharge would need to be of sufficient magnitude to allow for dry-season inspection and repair of the two existing tunnels, one at a time. With one tunnel still in service, the other could be rehabilitated as needed. This option would also include rehabilitation of the existing ocean outfalls.

6.2.6.2 Options Eliminated Through Level 1 Screening

Of the four conceptual options developed for management of effluent from the JWPCP, the following option was eliminated from further consideration.

JE 1 Existing Ocean Discharge System: Continued use of the existing ocean discharge system represents the most simplistic approach to effluent management. The reason for its elimination relates to

this option's inability to remove the existing tunnels from service, inspect their condition, and make repairs or rehabilitate them as needed. This element of the aging infrastructure of the JOS has not been inspected in over 50 years. Without the inspection of this critical component of the JWPCP effluent management system, the overall system's reliability would remain in question. Also, the existing tunnels both cross the Palos Verdes Fault, but neither was built to modern day seismic standards. Any system failure could lead to long-term violations of discharge standards and detrimental impacts on both the environment and public health. Furthermore, the existing onshore tunnels are also limited in terms of their 675-MGD hydraulic capacity. They are not capable of handling the estimated 927-MGD peak wet weather flow associated with the 400 MGD of average daily flow projected for the JWPCP by the year 2050.

6.2.6.3 Preliminary Options

Of the four conceptual options reviewed, three remain. The preliminary options for JWPCP effluent management are:

- **JE 2 New Ocean Discharge System**
- **JE 3 Modified Ocean Discharge System**
- **JE 4 Reduced Ocean Discharge**

A more-detailed description of each of these is provided in the subsections that follow.

JE 2 New Ocean Discharge System

In this preliminary option, a new ocean discharge system would be constructed. The major elements of a new system would include:

- Onshore tunnel
- Tunnel shafts
- Offshore tunnel or seafloor pipeline
- Riser and diffuser

The new onshore tunnel would extend from the JWPCP to the shoreline. A number of factors were considered in the development of tunnel alignments. These included:

- Locating the tunnel within public right-of-way
- Minimizing the tunnel's overall length
- Accommodating the required turning radius for non-linear sections
- Positioning the required tunnel shafts in acceptable locations

A large number of possible onshore tunnel alignments exist that would satisfy the baseline criteria.

Tunnel shafts include the working and access shafts used in the construction of the tunnel, as well as subsequent reconfiguration of the shafts for their use in operation and maintenance of the system. For the purposes of evaluating this option at this stage of the program-level alternatives analysis, it is assumed there would be two tunnel shafts. One shaft would be located at the JWPCP. This JWPCP shaft would initially function as a working shaft and would ultimately be converted to an effluent feed down shaft to the tunnel. The second shaft would be located near the shoreline, and its primary function would be to

provide supplemental ventilation during tunnel construction. Ultimately, the second shaft would be converted to an access and isolation point for future operation and maintenance.

The selection of an alignment for the offshore tunnel or seafloor pipeline would be dependent on the onshore tunnel alignment and location of the outfall diffuser. The offshore alignment could be constructed using a variety of techniques including:

- All seafloor pipeline
- All offshore tunnel
- A combination of seafloor pipeline and offshore tunnel

For the purposes of evaluating this option at this stage of the program-level alternatives analysis, it is assumed the marine conveyance facilities would consist of a combination of seafloor pipeline and offshore tunnel.

The primary factor in selecting a location for a riser and diffuser relates to the achievement of water quality objectives. Other factors considered include:

- Adequate depth and distance from shore: Performance must meet or exceed that of the existing diffusers
- Favorable currents: Avoid locations that may affect the shore
- Sufficient space: Ability to locate the diffusers, including room to site future diffusers
- Geotechnical stability: Locations with limited potential for significant movement during seismic events

For the purposes of evaluating this option at this stage of the program-level alternatives analysis, it is assumed the diffuser would be located in an area on the southern edge of the Palos Verdes Shelf (PV Shelf) or the San Pedro Shelf (SP Shelf). This places the new diffuser south and east of the existing ocean outfalls and satisfies the listed criteria.

JE 3 Modified Ocean Discharge System

In this preliminary option, a new tunnel would be constructed between the JWPCP and the existing manifold structure at Royal Palms Beach. The major elements of a modified ocean discharge system would include:

- Onshore tunnel
- Tunnel shafts
- Existing ocean outfalls

A number of factors were considered in the development of the onshore tunnel alignments. These included:

- Locating the tunnel within public right-of-way
- Minimizing the tunnel's overall length
- Accommodating the required turning radius for non-linear sections
- Positioning the required tunnel shafts in acceptable locations

A large number of possible onshore tunnel alignments exist that would satisfy the baseline criteria.

Tunnel shafts include the working and exit shafts used in the construction of the tunnel, as well as subsequent reconfiguration of these facilities for their use in operating the system. For the purposes of evaluating this option at this stage of the program-level alternatives analysis, it is assumed there would be two tunnel shafts. One shaft would be located at the JWPCP. This JWPCP shaft would initially function as a working shaft and would ultimately be converted to an effluent shaft to the tunnel. The second shaft would be located near the existing manifold structure at Royal Palms Beach and would function as an exit shaft for the tunneling equipment. Ultimately, the second shaft would be converted to an access and isolation point for future operation and maintenance.

The existing ocean outfalls would be used for diffusing JWPCP effluent. Recent inspections, physical testing, and a hydraulic analysis determined that the three largest outfalls have the structural integrity and capacity to last well beyond 2050.

JE 4 Reduced Ocean Discharge

This preliminary option would substantially reduce the discharge of effluent through the existing ocean discharge system so as to allow for tunnel dewatering, inspection, rehabilitation, and repair as needed. Flow reductions would be achieved by diverting a portion of the JWPCP effluent for reuse.

The only reuse application that could potentially accommodate the amount of treated effluent necessary to support this option is groundwater recharge. Groundwater recharge would be implemented through the use of spreading basins and, possibly, direct injection for the Central and Main San Gabriel Basins and direct injection wells for the West Coast Basin. During wet weather events, when JWPCP flows are peaking, spreading basin capacity is significantly reduced or unavailable. Therefore, tunnel inspection and repair work would need to be conducted during the dry season.

Currently, the JWPCP provides a secondary level of treatment, along with disinfection, to influent flows. A more advanced level of treatment would be required for groundwater recharge. The advanced level of treatment assumed would consist of microfiltration and reverse osmosis (MF/RO), ultraviolet disinfection, and advanced oxidation. Storage for peak diurnal flow attenuation would also be necessary.

This option would need to be implemented within the next 10 to 15 years in order to address the aging infrastructure concerns of the two existing tunnels in a timely manner. By 2025, it is estimated that the average daily flows at the JWPCP would be 335 MGD. This approach is predicated on the assumption that the two existing tunnels can be hydraulically isolated from each other. Based on a diurnal peak flow factor of 1.4 at the JWPCP, a peak flow capacity of 170 MGD in the 8-foot diameter tunnel, and 20 percent brine reject, this option would require approximately 250 MGD of advanced treatment (producing approximately 200 MGD of MF/RO permeate for groundwater recharge and 50 MGD of brine reject to be discharged to the one tunnel still in service) and 27 million gallons (MG) of storage volume.

The advanced treatment, storage, and groundwater recharge facilities would need to remain in operation during the entire planning period in order for the existing JWPCP ocean discharge system to have sufficient capacity to accommodate the projected 2050 average daily flows of 400 MGD and associated peak wet weather flows of 927 MGD.

6.2.6.4 Level 2 Screening

The screening parameters for the JE program component area are:

- Available land/right-of-way
- Institutional feasibility

- Regulatory compliance
- Public acceptability
- Operational flexibility, reliability, and familiarity
- Cost effectiveness

The application of the Level 2 screening parameters is shown in Table 6-23.

Table 6-23. Comparison of Preliminary Options to Level 2 Screening Parameters

	Available Land Right-of-Way	Institutional Feasibility	Regulatory Compliance	Public Acceptability	Operational Flexibility, Reliability, and Familiarity	Cost Effectiveness	Score	Ranking
JE 2 New Ocean Discharge System	0	0	+	0	+	-	+1	2
JE 3 Modified Ocean Discharge System	+	0	+	0	0	+	+3	1
JE 4 Reduced Ocean Discharge	0	-	0	+	-	-	-2	3

6.2.6.5 Options Eliminated Through Level 2 Screening

Of the three preliminary options for JWPCP effluent management, one was eliminated from further consideration.

JE 4 Reduced Ocean Discharge: This option would entail diverting a sufficient amount of flow from the existing ocean discharge system to allow for the inspection/repair of each of the existing tunnels during the dry season. The diverted flow would receive advance treatment before being conveyed to the Central, West Coast, and/or Main San Gabriel Basins for groundwater recharge. There may be enough property available at the JWPCP for approximately 250 MGD of advanced treatment facilities and 27 MG of storage tanks. However, this option would require numerous rights-of-way within major thoroughfares for very large diameter pipelines to convey recycled water to groundwater recharge sites. While increasing the use of recycled water would likely receive public acceptance on a conceptual level, the localized traffic and access disruption due to extensive pipeline construction would likely result in short-term, localized opposition. This option would be very dependent on the numerous inter-agency agreements for groundwater recharge and court-imposed groundwater management plans. Therefore, the institutional feasibility of this option is highly questionable. In addition, the successful procurement of environmental permits would present challenges; regulatory approval would be required for a new groundwater recharge project. The greatest concerns regarding this option relate to constructability, operational flexibility, reliability, and familiarity. Hydraulically separating the two existing tunnels while both are flowing full each day would be a complex undertaking. Then, tunnel inspection/repair work would ensue while sufficient flow is diverted to the advanced treatment facilities for groundwater recharge. The tunnel inspection/repair would need to occur during the dry season when flows are typically lower. However, there would always be the risk of a severe unseasonal storm event that could overwhelm the advanced treatment facilities. In which case, a portion of the secondary-treated JWPCP effluent would need to be diverted directly to the Wilmington Drain, which would be a violation of the

JWPCP discharge permit. This option would also require the operation of a completely new treatment system to enhance the JWPCP's effluent quality. In addition to being different than the existing plant facilities, the advanced treatment facilities are operationally complex. This lack of familiarity and system complexity would reduce the options' overall operational reliability. This option would also be expensive, even taking into consideration the market value of the recycled water produced. In addition to the capital costs of the treatment, transmission, and recharge facilities, there would be considerable energy costs associated with advanced treatment and effluent pumping. Even if all of these impediments could be overcome, it would be very difficult to implement this option by 2025. Only approximately 100 MGD of groundwater recharge capacity has been identified as being potentially available within this timeframe, which represents just half of what would be necessary to make this option viable.

The Sanitation Districts worked with the Metropolitan Water District of Southern California (MWD) during formulation and evaluation of this option. In October 2010, the MWD adopted its Integrated Water Resources Plan 2010 Update to address the challenges associated with the recent declines in the availability of imported water. With respect to pursuing a regional recycled water project, the MWD report only commits at this time to pursuing low-risk, low-cost "foundational actions" (e.g., feasibility studies, legislative efforts, and research) undertaken with the aim of reducing the implementation time of a recycled water project to reach full production, if deemed necessary in the future. If in the short run a significantly large reuse market materialized for JWPCP effluent and/or additional groundwater recharge capacity is identified, the viability of this option would merit reassessment.

6.2.6.6 Viable Options

Of the four preliminary options examined, two remain. The viable options for JWPCP effluent management are:

- **JE 2 New Ocean Discharge System**
- **JE 3 Modified Ocean Discharge System**

6.2.6.7 Level 3 Screening

The screening of the two remaining options consisted of a project-level alternatives analysis, which is detailed in Section 6.3.

6.2.6.8 Viable Options Eliminated

No viable options were eliminated.

6.2.6.9 Feasible Options

The feasible options for JWPCP effluent management are:

- **JE 2 New Ocean Discharge System**
- **JE 3 Modified Ocean Discharge System**

Unlike the other program component areas of the alternatives analysis, the feasible options for JWPCP effluent management were analyzed in greater detail at project level to determine their rankings. This project-level analysis is presented in Section 6.3, and the ranked feasible options for JWPCP Effluent Management are identified in Section 6.3.4.3.

A summary of the JOS program-level alternatives analysis is shown on Figure 6-2.

6.3 Project Analysis by Project Elements

Within the various program component areas evaluated in connection with the program-level JOS alternatives analysis, the two feasible options for JWPCP effluent management consisted of implementing either a new ocean discharge system or a modified ocean discharge system. This section provides an analysis of project element options for the ocean discharge system alternatives related to a new or modified ocean discharge system.

6.3.1 Alternatives Development and Analysis Process

The approach employed to evaluate the project is similar to that undertaken for the program-wide assessment of the JOS. First, the overall project was divided into five project *elements*. Conceptual and preliminary options for each project element were screened to determine the viable options. The viable options from the project elements were then combined to formulate viable project alternatives, which were evaluated to determine a set of ranked feasible project alternatives. The highest ranked feasible alternative was identified as the recommended project. This process is depicted on Figure 6-3. Finally, as previously shown on Figure 6-2, these ranked feasible project alternatives for JWPCP effluent management were combined with the feasible program alternatives to arrive at a recommended plan for the Clearwater Program.

Parsons Water and Infrastructure, Inc., in association with Jacobs Associates and Black & Veatch, provided much of the technical support for the project-level alternatives analysis. Their input is documented in the Professional Design Services for the Preliminary Engineering of the Joint Water Pollution Control Plant Tunnel and Ocean Outfall Feasibility Report, dated September 2011.

6.3.2 Study Area

The initial step in the project analysis was to develop a study area. The study area represents the conceptual boundary within which various physical project elements could be sited.

The three criteria used as the basis for the development of the study area were:

- Minimize interferences with discharges from other publicly owned treatment works (POTW) outfalls in the area, namely those of the city of Los Angeles and the Orange County Sanitation District
- Stay within the edge of the continental shelf – either the PV Shelf or SP Shelf
- Use as direct a route as practicable between the JWPCP and the ocean diffuser area
- Avoid Marine Protected Areas (MPAs)

The subsequent formulation and assessment of options and alternatives were consistent with these criteria.

On the basis of the criteria used for establishing the project study area boundaries, the area under consideration for a new or modified ocean discharge system is shown on Figure 6-4. This 90-square-mile study area is fan shaped with its apex positioned at the JWPCP. On the westerly side, the fan extends southward from the JWPCP to the existing ocean outfalls. On the easterly side, the fan extends from the JWPCP to the intersection of the Palos Verdes Fault and the SP Shelf.

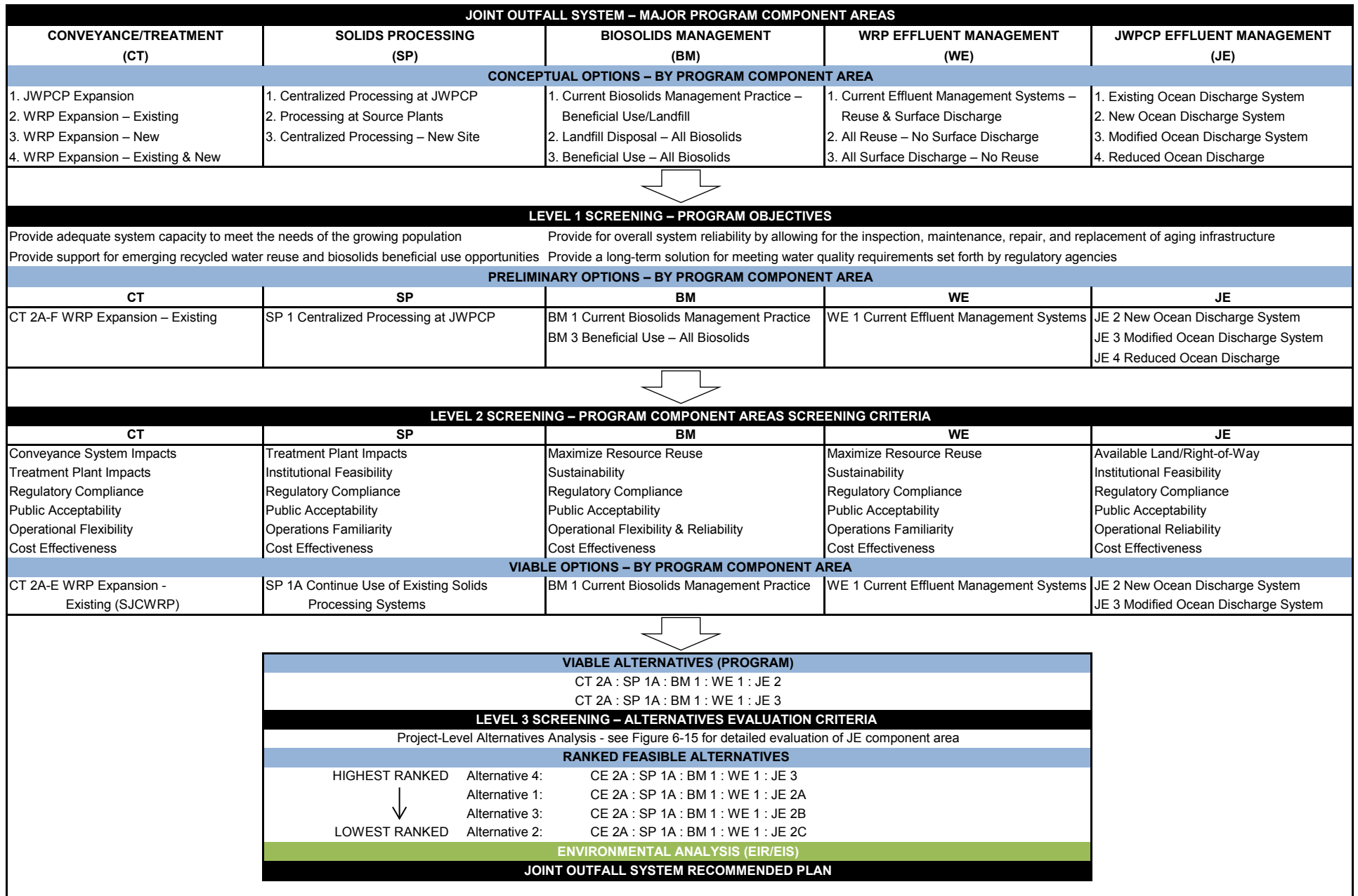

FIGURE 6-2

JWPCP EFFLUENT MANAGEMENT – OCEAN DISCHARGE SYSTEM PROJECT ELEMENTS

**Onshore
Alignment**

**Offshore
Alignment**

**JWPCP
Shaft Sites**

**Intermediate
Shaft Sites**

**Diffuser
Area**

Study Area

LEVEL 1 SCREENING
BASIC
REQUIREMENTS

Preliminary Options – By Project Elements

LEVEL 2 SCREENING
PROJECT ELEMENT
SCREENING
CRITERIA

Viable Options – By Project Elements

COMBINE PROJECT
ELEMENT OPTIONS
INTO PROJECT
ALTERNATIVES

Viable Project Alternatives

LEVEL 3 SCREENING
ALTERNATIVES
EVALUATION CRITERIA

Ranked Feasible Project Alternatives

ENVIRONMENTAL
ANALYSIS (EIR/EIS)

RECOMMENDED PROJECT

FIGURE 6-3



FIGURE 6-4

6.3.3 Evaluation of Project Elements

For the purpose of initial options formulation and assessment, the ocean discharge systems examined were divided into five project elements based on primary functionality. These are:

- Onshore tunnel alignment
- JWPCP shaft site
- Intermediate shaft site
- Diffuser area
- Offshore alignment

The initial development and evaluation of options was compartmentalized within these five project elements through the viable options stage. At that point, the viable options were combined into comprehensive discharge system alternatives.

6.3.3.1 Onshore Tunnel Alignment

The onshore alignment would begin at the JWPCP and end near the coast. The onshore alignment would be approximately 6 to 7 miles in length, ranging in depth from approximately 70 to 450 feet below ground level. Due to the depths of excavation that would be needed, open-cut trenching for the onshore alignment was deemed infeasible. Therefore, the onshore alignment would be constructed as a tunnel using a tunnel boring machine (TBM). This approach avoids the complication of open-cut trenching, including traffic and business disruptions as well as impacts on existing utilities and other underground facilities.

Preliminary Options

The Level 1 screening criteria used for the development of the conceptual options for the tunnel alignment were:

- Existing easements or public rights-of-way would be used to the maximum extent practicable
- The routing must allow a sufficient turning radius for the TBM (approximately 800 to 1,000 feet)
- The overall length of the alignment should be minimized

On the basis of these criteria, 23 conceptual options for an onshore tunnel alignment were originally identified. One of these options was an alignment that parallels the existing tunnels. However, the 68 current easements would not permit construction of a new tunnel, and a parallel tunnel alignment just outside the existing easements would require approximately 1,060 new easements. Therefore, this conceptual option was eliminated, and a total of 22 options were carried forward for an onshore alignment. The preliminary options for onshore tunnel alignments are:

- **Wilmington Blvd – Port of Los Angeles**
- **Frigate Ave – Port of Los Angeles**
- **Figueroa St – Port of Los Angeles**
- **Frigate Ave – China Shipping – Harbor Blvd**
- **Figueroa St – China Shipping – Harbor Blvd**
- **Frigate Ave – John S Gibson Blvd – Harbor Blvd**

- **Figueroa St – John S Gibson Blvd – Harbor Blvd**
- **Figueroa St – Harbor Regional Park – North Gaffey St – Harbor Blvd**
- **Frigate Ave – John S Gibson Blvd – Pacific Ave – Cabrillo Beach**
- **Figueroa St – John S Gibson Blvd – Pacific Ave – Cabrillo Beach**
- **Figueroa St – Harbor Regional Park – North Gaffey St – Pacific Ave – Cabrillo Beach**
- **Frigate Ave – John S Gibson Blvd – Pacific Ave**
- **Figueroa St – John S Gibson Blvd – Pacific Ave**
- **Figueroa St – Harbor Regional Park – North Gaffey St – Pacific Ave**
- **Frigate Ave – John S Gibson Blvd – South Gaffey St**
- **Figueroa St – John S Gibson Blvd – South Gaffey St**
- **Figueroa St – Harbor Regional Park – North Gaffey St – South Gaffey St**
- **Frigate Ave – John S Gibson Blvd – Capitol Dr – Western Ave**
- **Figueroa St – John S Gibson Blvd – Capitol Dr – Western Ave**
- **Figueroa St – Harbor Regional Park – North Gaffey St – Capitol Dr – Western Ave**
- **Figueroa St – Harbor Regional Park – Navy Fuel Depot – Western Ave**
- **Lomita Blvd – Western Ave**

The preliminary options for onshore tunnel alignments are shown on Figure 6-5. These alignment designations reflect the major streets under which each tunnel option is located.

Viable Options

A total of 22 preliminary options for an onshore tunnel alignment were identified. Level 2 screening parameters used in the assessment of these options were:

- Minimize exposure to major geotechnical faults
- Ensure compatibility with intermediate shaft site locations
- Reduce the number of easements required
- Favor overlapping alignments with shorter overall lengths

On this basis, the 22 preliminary options were reduced to 8 viable options for the onshore tunnel alignment. The options that did not have an appropriate intermediate shaft site and were, therefore, eliminated included the alignments along Harbor Boulevard, Pacific Avenue, and Cabrillo Beach. The Figueroa Street alignment that extends to the Port of Los Angeles was eliminated because it runs parallel and in close proximity to the Palos Verdes Fault zone. This alignment also potentially interferes with the West Turning Basin of the Port of Los Angeles. The alignments that begin on Frigate Avenue and continue to South Gaffey Street and Western Avenue were eliminated because the majority of the alignments are identical to the Figueroa Street alignments that follow the same path, and the Frigate Avenue alignments are longer.

Of the 22 preliminary options reviewed, eight remain. The viable options for onshore tunnel alignments are:

- **Wilmington Blvd – Port of Los Angeles**

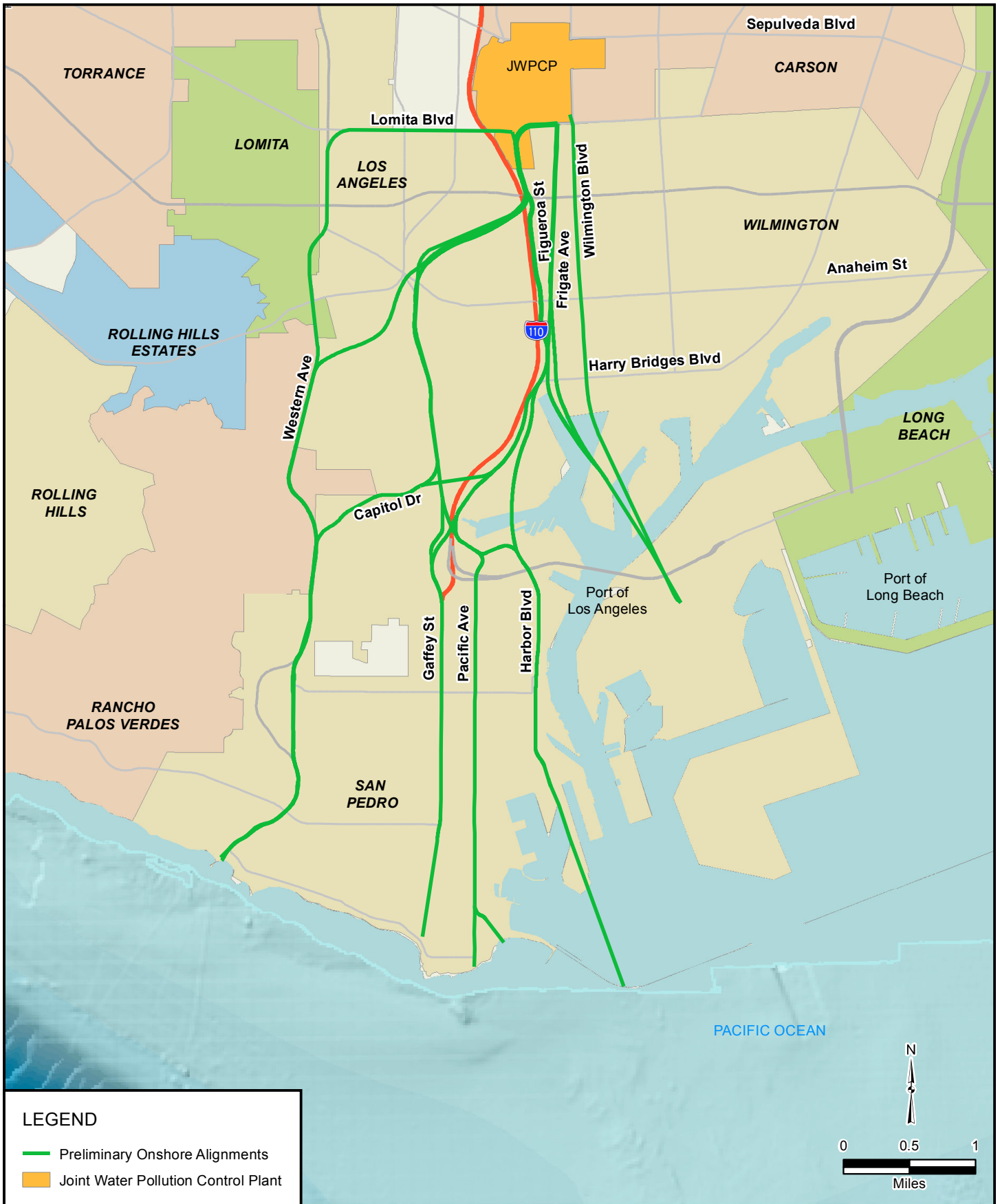

- **Frigate Ave – Port of Los Angeles**
- **Figueroa St – John S Gibson Blvd – South Gaffey St**
- **Figueroa St – Harbor Regional Park – North Gaffey St – South Gaffey St**
- **Figueroa St – John S Gibson Blvd – Capitol Dr – Western Ave**
- **Figueroa St – Harbor Regional Park – North Gaffey St – Capitol Dr – Western Ave**
- **Figueroa St – Harbor Regional Park – Navy Fuel Depot – Western Ave**
- **Lomita Blvd – Western Ave**

These viable options for onshore tunnel alignments are shown on Figure 6-6 and carried forward for the development of viable project alternatives in Section 6.3.4.1.

6.3.3.2 JWPCP Shaft Site

For all alternatives, one end of the tunnel would be at the JWPCP; therefore, a shaft site would be required at the JWPCP to facilitate tunnel construction. The shaft site at the JWPCP would be classified as a working shaft and would require sufficient access and area to permit the insertion of the TBM, ancillary equipment, tunnel segments, and personnel, as well as the continuous removal of excavation materials that originate from the tunneling process. Tunneling would take place over a period of years and, therefore, the working shaft would be an active construction site over this time. Ultimately, the shaft would function as the connection between the existing facilities and the new or modified ocean discharge system.

Preliminary Options

Level 1 screening parameters for location of a JWPCP shaft site are:

- The majority of the site must be within the confines of the JWPCP property boundaries
- The location must avoid conflicts with current facilities or planned future facilities
- The minimum area requirement is 8 acres
- The geometry of the area must be roughly rectangular to square
- The area must be relatively flat
- There must be access for equipment, ventilation systems, and personnel, as well as long-term access for excavation material removal on a continuous basis

On the basis of these criteria, two options were identified. The preliminary options for a JWPCP shaft site are:

- **JWPCP East shaft site**
- **JWPCP West shaft site**

The preliminary options for a JWPCP shaft site are shown on Figure 6-7.

Viable Options

A total of two preliminary options for a JWPCP shaft site were identified. Level 2 screening parameters used in the assessment of these options were:

- Compatibility of location with current land use





- Avoidance of major environmental concerns based on a preliminary assessment
- Avoidance of major impacts on public use facilities
- Institutional constraints relative to use

Both of the proposed shaft sites at the JWPCP were compliant with the screening parameters. Therefore, the viable options for a JWPCP shaft site are:

- **JWPCP East shaft site**
- **JWPCP West shaft site**

These viable options for the JWPCP shaft site were carried forward for the development of viable system alternatives in Section 6.3.4.1.

6.3.3.3 Intermediate Shaft Site

An intermediate shaft site, depending on available area, access, and project requirements, would fall into one of three categories:

- **Working Shaft:** A working shaft site would be used for approximately 4 to 8 years as the aboveground staging area for the tunneling construction and support system activities. The working shaft would serve as the entry point for construction workers and as the exit point for all of the excavated material.
- **Access Shaft:** An access shaft site would be used primarily for supplemental ventilation during tunnel construction. It would also be available as an entry and exit point for construction workers, TBM maintenance, and removal of salvageable portions of the TBM at the project's conclusion. The access shaft site would be approximately 0.5 to 3 acres.
- **Exit Shaft:** An exit shaft site would be used for the removal of the TBM and have a land requirement of approximately 1 to 4 acres.

Preliminary Options

Level 1 screening parameters for location of an intermediate shaft site are:

- Area requirements depending on type of shaft
- Relatively flat
- The geometry of the area must be roughly rectangular to square
- Public land
- Close proximity to onshore tunnel alignment

On the basis of these criteria, the following 13 locations were identified as preliminary options for an intermediate shaft site:

- **Navy Fuel Depot**
- **Peck Park**
- **Averill Park**
- **White Point Nature Preserve**
- **Field of Dreams**

- **Fort MacArthur**
- **Angels Gate Park**
- **Point Fermin Park**
- **Port of Los Angeles (3)**
 - **Trans Pacific Container Service Corporation (TraPac)**
 - **Los Angeles Export Terminal (LAXT)**
 - **Southwest Marine**
- **Royal Palms Beach**
- **Cabrillo Beach**

The preliminary options for intermediate shaft sites are shown on Figure 6-8.

Viable Options

A total of 13 preliminary options were identified for an intermediate shaft site. Level 2 screening parameters used in the assessment of these options were:

- Avoidance of sites that have incompatible land uses such as landfills, military land, and other lands that entail national security
- Avoidance of sites that present significant environmental concerns such as those designated for conservation or that support endangered species
- Avoidance of sites that are currently used for public recreational activities such as parks, beaches, and athletic fields because the shaft site would use a considerable portion of the available recreational area.
- Avoidance of sites that may be contaminated to the degree where remediation is required
- Consideration of input from local jurisdictions and the general public with respect to shaft locations

The Navy Fuel Depot was eliminated due to the potential for contamination, disruption to the function of the Navy facilities, and potential impact on the Palos Verdes Peninsula Land Conservancy plans for coastal sage brush habitat preservation. Peck Park, Averill Park, and Point Fermin Park were eliminated from consideration based on the conflicts with the public recreational uses of these facilities and public input. The White Point Nature Preserve was eliminated from consideration due to its biological significance and public input. The Field of Dreams was eliminated due to its prior use as a landfill, its heavy recreational use, and public input. Fort MacArthur was eliminated due to its interference with current use and concerns raised by the Air Force over national security. Cabrillo Beach was eliminated due to the potential for extended beach closures and public input.

Of the 13 preliminary options evaluated, five remain. The viable options for an intermediate shaft site are:

- **Port of Los Angeles – TraPac (access shaft site)**
- **Port of Los Angeles – LAXT (working shaft site)**
- **Port of Los Angeles – Southwest Marine (access shaft site)**
- **Angels Gate Park (access shaft site)**



- **Royal Palms Beach (exit shaft site)**

The viable options for an intermediate shaft site are shown on Figure 6-9 and were carried forward in the development of offshore alignments described in Section 6.3.3.5 and the viable project alternatives in Section 6.3.4.1.

6.3.3.4 Diffuser Area

The diffuser area is where effluent would be discharged to the ocean. The length of the diffuser would depend on a variety of factors including projected flows and discharge depth. An underlying criterion for the proposed diffuser is that it should perform as well as the existing diffusers. To attain this criterion, initial parameters of distance from shore, discharge depth, and bathymetry profile were established. In addition, the diffuser area had to avoid the existing ocean outfalls and be located in a geotechnically stable area. Locations for a diffuser area that had sufficient length to construct a diffuser at a fairly constant bathymetric contour (same depth) were preferred over locations where the diffuser would need to be constructed at varying depths.

Preliminary Options

Level 1 screening parameters for the development of potential diffuser areas are:

- The new ocean outfall system must perform equal to, or better than, the existing ocean outfall system with respect to achieving water quality objectives
- The location and discharge should be such that it does not significantly influence other POTW outfalls
- The diffuser must be located in a geotechnically stable area with respect to slope stability and potential lateral movement
- There should be a somewhat consistent slope to the area with relatively straight contours

Based on these criteria, the following four locations areas were identified as preliminary options for a diffuser area:

- **Diffuser Area A:** Off Point Fermin on the PV Shelf, adjacent to the location of the Sanitation Districts' existing ocean outfalls
- **Diffuser Area B:** East of the San Pedro Sea Valley
- **Diffuser Area C:** On the southern edge of the SP Shelf
- **Existing Ocean Outfalls**

The preliminary options for a diffuser area are shown on Figure 6-10.

Viable Options

Four separate locations were identified as preliminary options for a potential diffuser area location.

Level 2 screening parameters used in the assessment of these options were:

- Areas situated where favorable ocean conditions exist to decrease the potential for water quality impacts on sensitive receptors
- Sufficient length and space to accommodate the construction of a diffuser system that could accommodate JWPCP flows beyond the 2050 projections



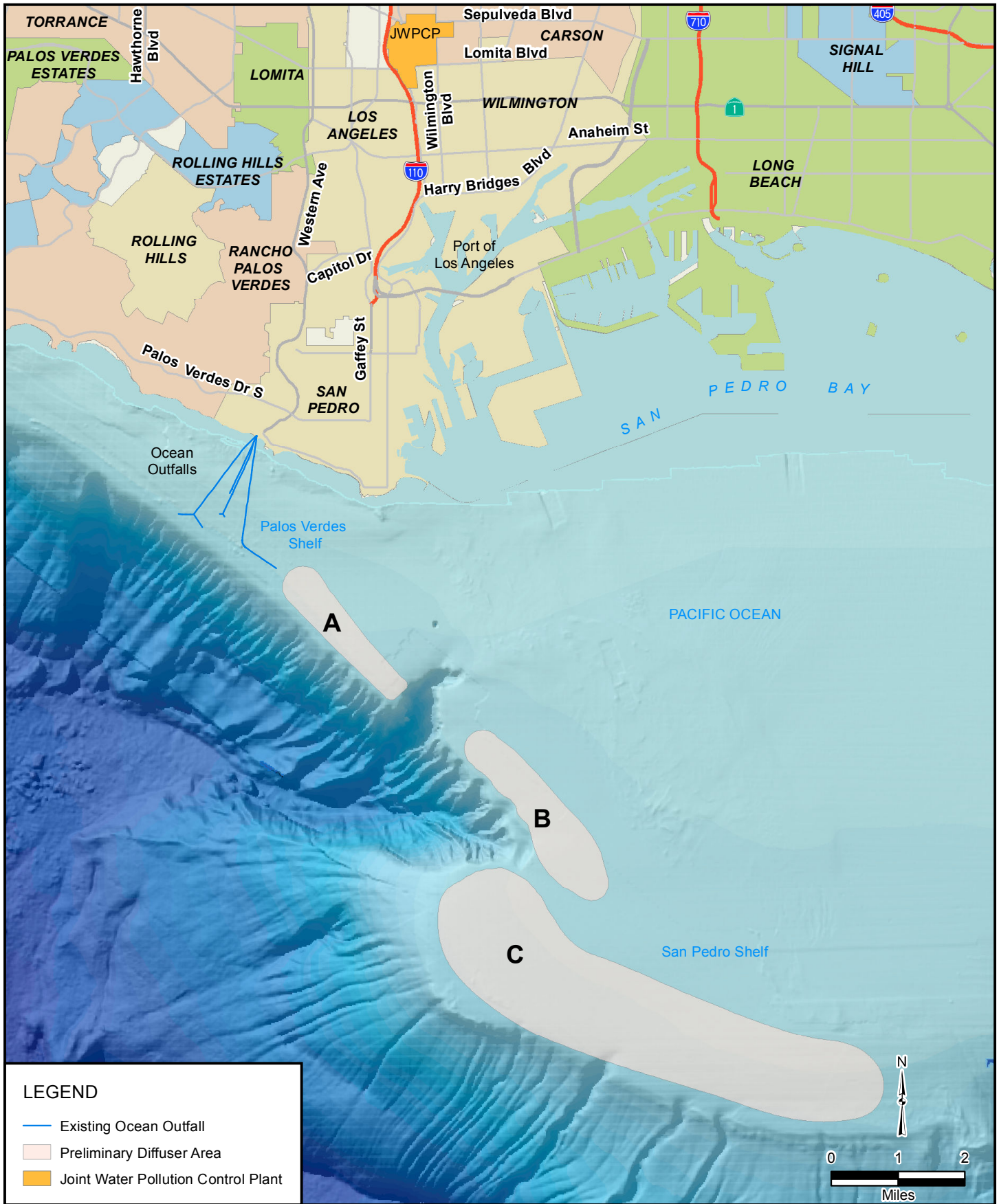

On this basis, Diffuser Area B was eliminated from consideration because of its location within active shipping lanes, proximity to the shoreline, potential for water quality impacts due to shallower depth and poor initial dilution, unfavorable currents, and insufficient area to accommodate the diffuser length that could be required.

Of the four preliminary options evaluated, three remain. The viable options for a diffuser area are:

- **Diffuser Area A (hereinafter referred to as PV Shelf)**
- **Diffuser Area C (hereinafter referred to as SP Shelf)**
- **Existing Ocean Outfalls**

These three diffuser area locations, shown on Figure 6-11, were carried forward as viable options and used in the development of offshore alignments described in Section 6.3.3.5 and the viable system alternatives in Section 6.3.4.1.

6.3.3.5 Offshore Alignment

The offshore alignment would connect an intermediate shaft site to the diffuser. The alignment could consist of a tunnel or a combination of a tunnel and a seafloor pipeline. Because each offshore alignment is dependent on the locations of the intermediate shaft site and the diffuser area, preliminary options for the offshore alignment were established after the viable options for the intermediate shaft site and diffuser area were determined.

Preliminary Options

Level 1 screening parameters for the development of potential offshore alignments were:

- Viable intermediate shaft site (working, access, or exit)
- Viable diffuser area
- Tunnel only or a combination of tunnel and seafloor pipeline

The remaining viable options for intermediate shaft sites included three in the Port of Los Angeles, one at Angels Gate Park, and one at Royal Palms Beach. Because all onshore alignments through the Port of Los Angeles end at the LAXT shaft site, it would serve as the origin of all offshore alignments through the Port of Los Angeles. Beginning at the LAXT shaft site, an alignment could continue through Pier 400 to the east of the Palos Verdes Fault into the ocean and cross the fault in the ocean, or the alignment could cross the Palos Verdes Fault within the port and continue through the Southwest Marine shaft site into the ocean. The Angels Gate shaft site would serve as the beginning of any offshore alignment through that shaft site. The Royal Palms shaft site would be an exit shaft connecting to the existing ocean outfalls and, therefore, would not serve as the start of an offshore alignment. In determining preliminary options for the offshore alignment, only the LAXT and Angels Gate shaft sites would be considered for the origin of the offshore alignment.

Combining the two shaft sites, the two viable diffuser area locations, and the type of alignments (tunnel or combined tunnel and seafloor pipeline) resulted in the following 12 preliminary options for offshore tunnel alignments:

- **LAXT through Pier 400 to PV Shelf (tunnel)**
- **LAXT through Pier 400 to PV Shelf (combined)**
- **LAXT through Pier 400 to SP Shelf (tunnel)**

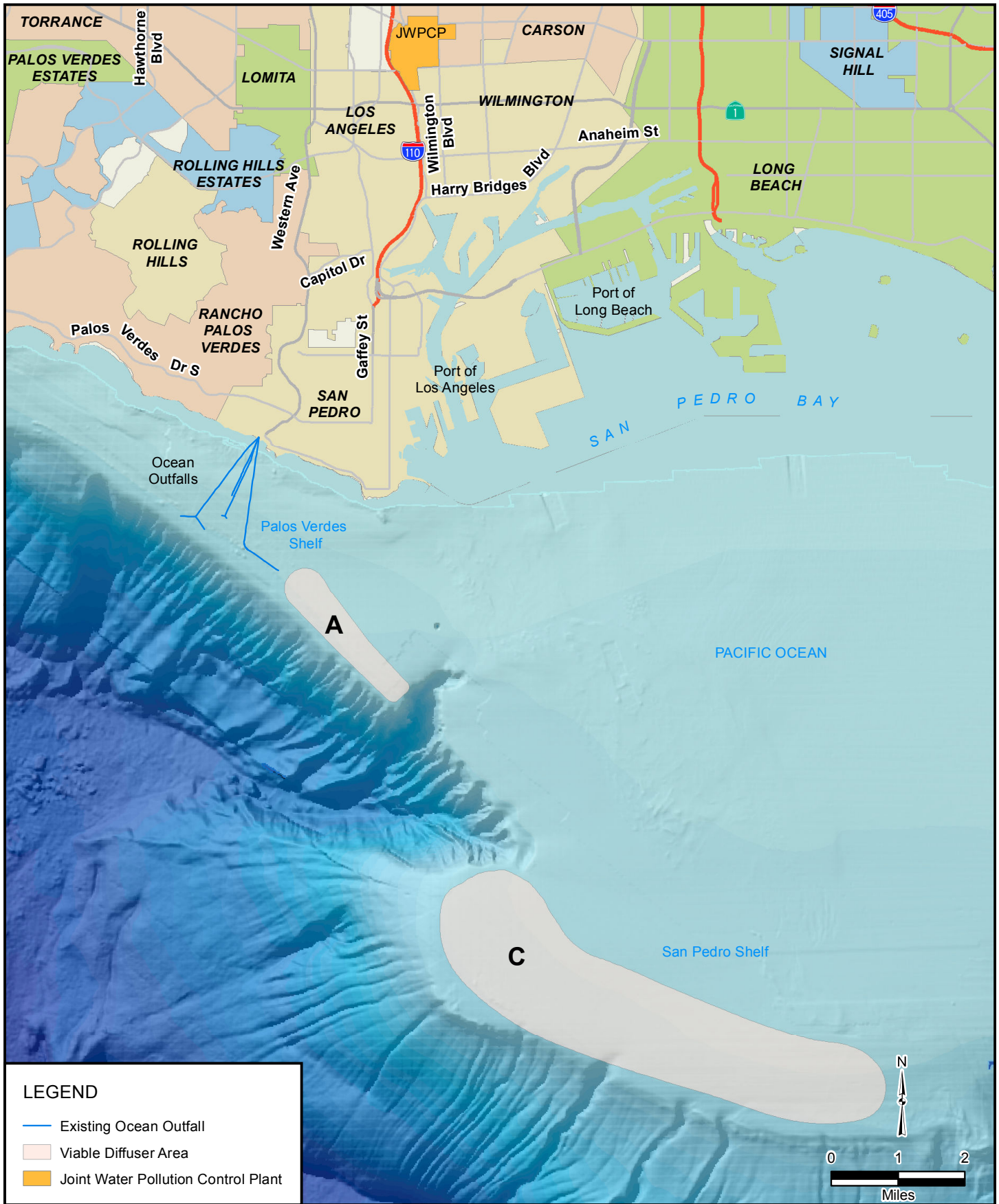

FIGURE 6-11

- **LAXT through Pier 400 to SP Shelf (combined)**
- **LAXT through Southwest Marine to PV Shelf (tunnel)**
- **LAXT through Southwest Marine to PV Shelf (combined)**
- **LAXT through Southwest Marine to SP Shelf (tunnel)**
- **LAXT through Southwest Marine to SP Shelf (combined)**
- **Angels Gate to PV Shelf (tunnel)**
- **Angels Gate to PV Shelf (combined)**
- **Angels Gate to SP Shelf (tunnel)**
- **Angels Gate to SP Shelf (combined)**

The preliminary options for offshore alignments are shown on Figure 6-12.

Viable Options

Level 2 screening parameters used in the assessment of the 12 preliminary options for an offshore alignment were:

- Maximum depth of riser is 200 feet of water
- Maximum length of submarine tunnel in rock is 10 miles
- Maximum length of submarine tunnel in soil is 4 miles
- Minimization of costs
- Minimization of marine impacts
- Avoidance of crossing the Palos Verdes Fault in the ocean

All options with combined tunnel and seafloor pipeline were eliminated because construction of a seafloor pipeline would increase the cost and marine impacts. The options that went from LAXT through Pier 400 to both the PV Shelf and the SP Shelf were eliminated because they would cross the Palos Verdes Fault in the ocean and would require an extensive amount of seafloor pipeline, which would increase the cost and marine impacts. The option that went from Angels Gate to SP Shelf was eliminated because it exceeded the maximum length of tunnel drive. Of the 12 preliminary options evaluated, three remain. The viable options for an offshore alignment are:

- **Angels Gate to PV Shelf (tunnel)**
- **LAXT through Southwest Marine to PV Shelf (tunnel)**
- **LAXT through Southwest Marine to SP Shelf (tunnel)**

These three offshore alignments were carried forward as viable options and used in the development of viable system alternatives in Section 6.3.4.1.

6.3.4 Development and Screening of Project Alternatives

6.3.4.1 Viable Alternatives

The next step in the alternatives development and assessment process for a new or modified ocean discharge system was the generation of viable alternatives. As previously described, viable options for

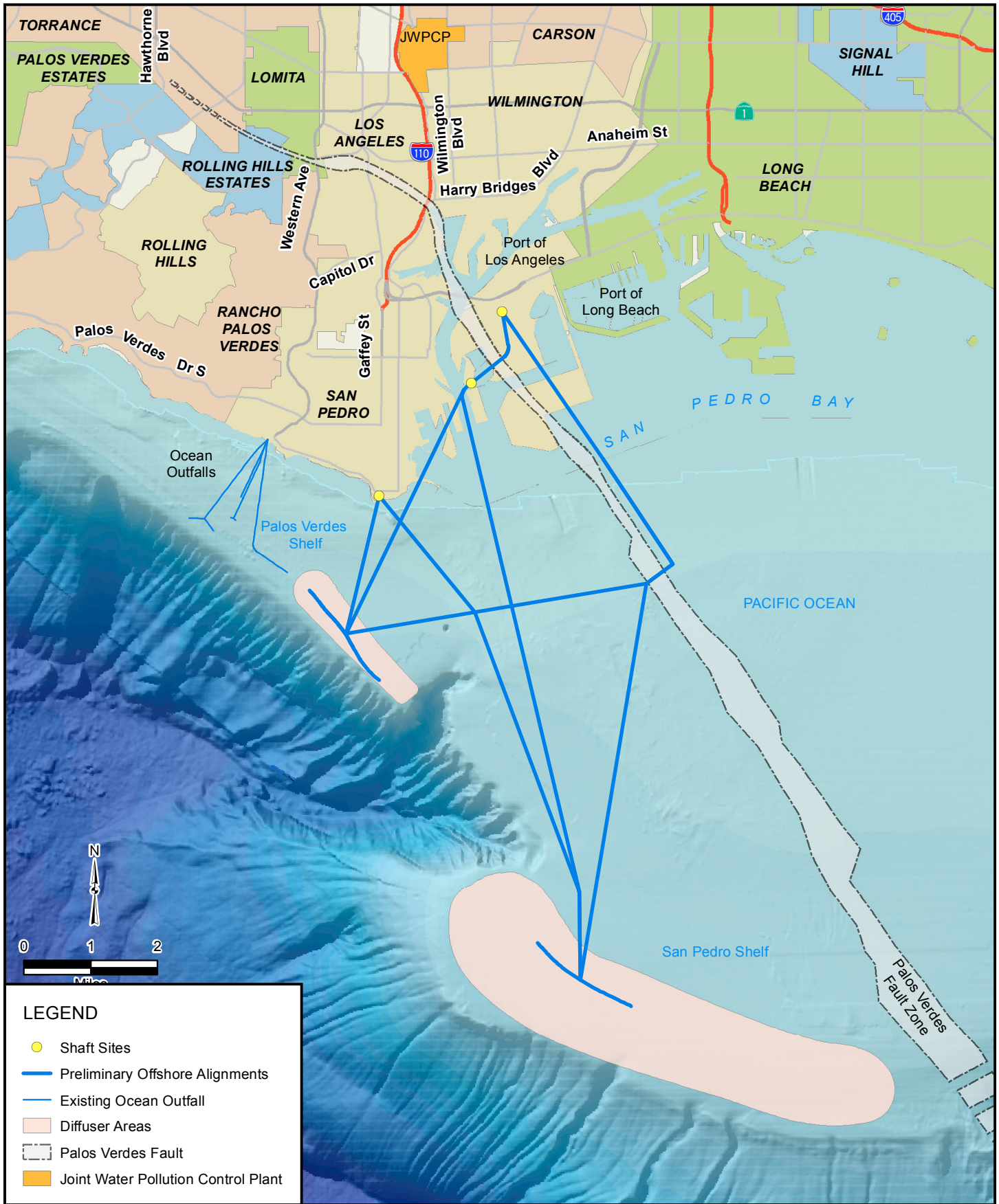

FIGURE 6-12

each project element area were identified. These viable options were then combined into viable alternatives for a new or modified ocean discharge system.

Various permutations of viable options from each project element were amalgamated into viable alternatives that are logical and practical in terms of the resulting functionality (e.g., a viable intermediate shaft site would only be paired with a viable onshore alignment if the shaft site were adjacent to the alignment).

The number of viable options for each project element is as follows:

- Onshore alignment (8)
- JWPCP shaft site (2)
- Intermediate shaft site (5)
- Diffuser area (3)
- Offshore alignment (3)

Logically combining these various options into comprehensive alternatives resulted in a total of 10 viable alternatives for an ocean discharge system. These 10 viable alternatives can be further categorized as either new ocean discharge systems or modified ocean discharge systems. The viable project alternatives for each category are listed in Table 6-24 and Table 6-25, respectively, and shown on Figure 6-13.

Table 6-24. Viable Alternatives: New Ocean Discharge System

JWPCP Shaft Site	Onshore Alignment	Intermediate Shaft Sites	Offshore Alignment	Diffuser Area
JWPCP East	Wilmington	TraPac, LAXT, Southwest Marine	LAXT through Southwest Marine to SP Shelf	SP Shelf
JWPCP East	Frigate	TraPac, LAXT, Southwest Marine	LAXT through Southwest Marine to SP Shelf	SP Shelf
JWPCP East	Wilmington	TraPac, LAXT, Southwest Marine	LAXT through Southwest Marine to PV Shelf	PV Shelf
JWPCP East	Frigate	TraPac, LAXT, Southwest Marine	LAXT through Southwest Marine to PV Shelf	PV Shelf
JWPCP West	N Gaffey – S Gaffey	Angels Gate	Angels Gate to PV Shelf	PV Shelf
JWPCP West	Figueroa – S Gaffey	Angels Gate	Angels Gate to PV Shelf	PV Shelf

Table 6-25. Viable Alternatives: Modified Ocean Discharge System

JWPCP Shaft Site	Onshore Alignment	Intermediate Shaft Site	Diffuser Area
JWPCP West	Figueroa – John S Gibson – Capitol – Western	Royal Palms	Existing Outfalls
JWPCP West	Figueroa – Harbor Regional Park – North Gaffey – Capitol – Western	Royal Palms	Existing Outfalls
JWPCP West	Figueroa – Harbor Regional Park – Navy Fuel Depot – Western	Royal Palms	Existing Outfalls
JWPCP West	Lomita – Western	Royal Palms	Existing Outfalls

6.3.4.2 Level 3 Screening

The next step in the alternatives development and assessment process for a new or modified ocean discharge system was the Level 3 screening of viable alternatives and determination of ranked feasible alternatives to carry forward for detailed environmental analysis in the associated EIR/EIS.

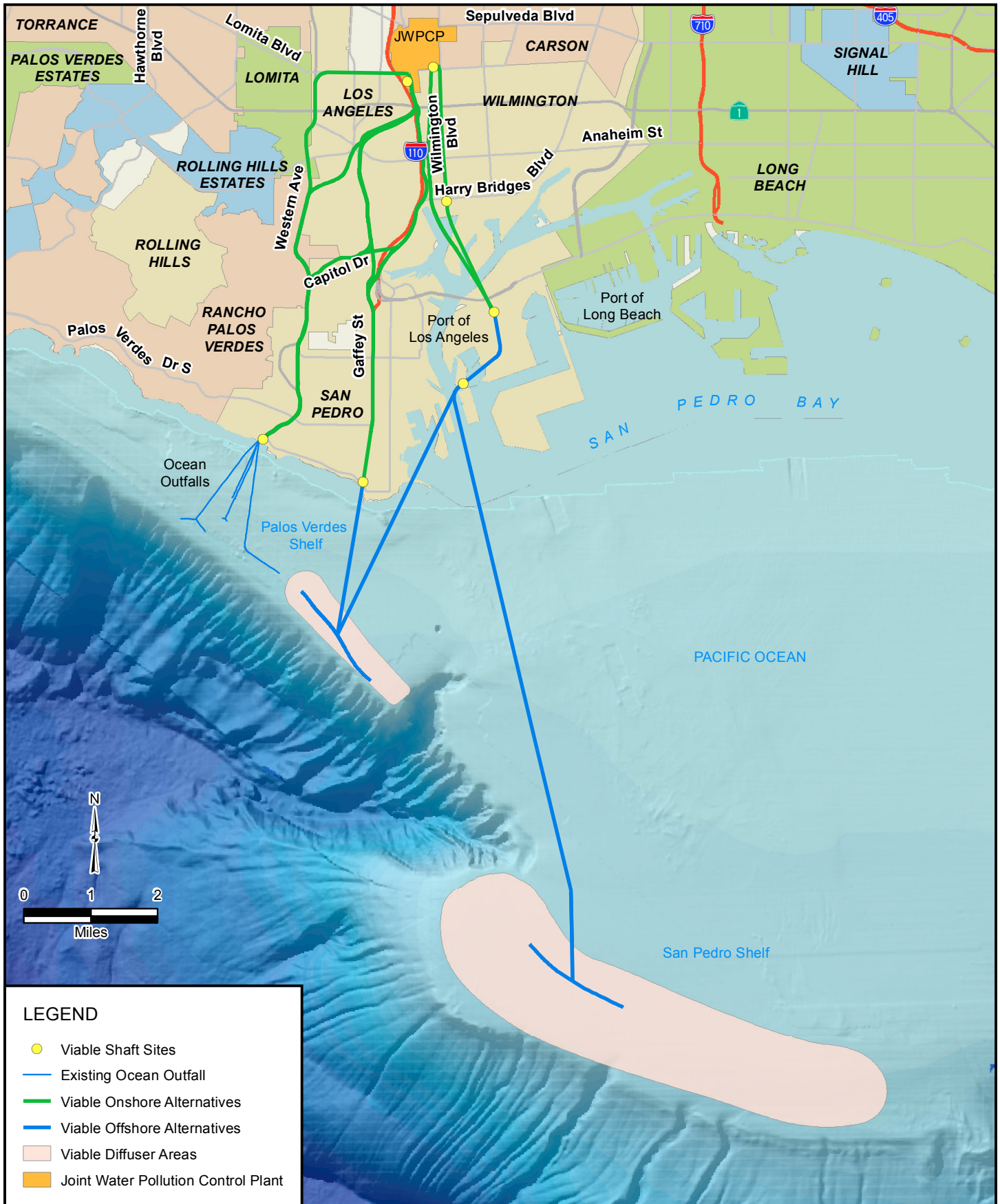

FIGURE 6-13

The Level 3 screening process employed a multi-criteria decision support software tool to facilitate the overall assessment effort. The software provided the flexibility to investigate a wide range of evaluation approaches and allowed for a sensitivity analysis of outcomes. The steps in assessing the viable alternatives and determining the ranked feasible alternatives were as follows:

- Determine screening parameters, parameter weights, and guidelines for application of criteria
- Disaggregate viable alternatives into project elements and determine importance factors to apply to each project element in scoring compilation
- Score the project elements of each alternative with respect to the screening parameters and apply importance factor weights
- Compile aggregate weighted scores for each alternative by applying screening parameter weights and totaling the weighted element scores
- Carry forward top scoring alternatives as ranked feasible alternatives for detailed environmental assessment

Screening Parameters and Weighting

Viable alternatives were evaluated with respect to their relative ranking against a set of screening parameters. The criteria and relative weights used in the assessment process are listed in Table 6-26.

Table 6-26. Screening Parameters and Weighting

Screening Parameter	Weight (Percent)
Environmental Impacts	20
Public Input	15
Operational Considerations	10
Constructability	15
Long-Term Uncertainty	20
Cost Effectiveness	20

The assigned weights reflect the Sanitation Districts' assessment of the relative importance of each of these parameters in the decision-making process. The screening parameters were selected and defined so as to provide measurable, comprehensive, and independent results. Each option was scored on a system from zero (worst) to ten (best). Each of these parameters is briefly discussed in the paragraphs that follow.

Environmental Impacts

Environmental impacts consider both the short-term (construction) and long-term (operational) impacts related to the subject alternative. This parameter takes into account both the extent of construction and the sensitivity of areas affected. The scores for this parameter range from zero, for a high degree of impacts and a high level of mitigation required, to ten, for limited impacts and no mitigation required.

Public Input

Public input considers the relative degree of public acceptance anticipated for the subject alternative. This includes views of individuals and community groups collected as part of a public outreach program. If documented public input was unavailable, public perception was anticipated or inferred. The scores for this parameter range from zero, for a high degree of public opposition, to ten, for positive public perceptions and support.

Operational Considerations

Operational considerations deal with the benefits the subject alternative provides to the ongoing operation of the JWPCP. Operational flexibility, redundancy, and anticipated O&M and monitoring costs are among the factors evaluated in this category. The scores for this parameter range from zero, for no flexibility and high O&M and monitoring costs, to ten, for a high degree of flexibility and low O&M and monitoring costs.

Constructability

Constructability considers the relative ease or difficulty of constructing the facilities for the subject alternative. For instance, would construction require methods that are commonly used or would it require innovative techniques? Seismic design is considered in this category, as well as the hazards that may be encountered during construction. Institutional feasibility, an indication of the Sanitation Districts' control over a given alternative, is also considered. The scores for this parameter range from zero, for highly complex construction methods, state-of-the-art technology, many hazards, and dependence on third-party approvals, to ten, for relatively easy, standard construction, limited hazards, and greater Sanitation Districts' control.

Long-Term Uncertainty

Long-term uncertainty considers the impacts of future events and changes in conditions that may occur but cannot be predicted (e.g., future flows and regulatory requirements). Areas such as seismic vulnerability and the ability to access and repair the elements of the subject alternative are considered as well. Asset reliability and expansion potential are also considered in this category. The scores for this parameter range from zero, if future significant events and conditions would require significant effort or changes, to ten, if future significant events and conditions could be handled with relative ease or no changes.

Cost Effectiveness

Cost effectiveness considers the capital costs associated with the implementation of the subject alternative. The scores for this parameter range from zero, for the most expensive alternative, to ten, for a no-cost alternative.

Project Element Importance Factors

Some of the project elements play a greater role in the development of the alternatives or have greater importance than the others. Each project element was assigned an importance factor based on the Sanitation Districts' assessment its relative importance. Subsurface project elements, particularly the offshore tunnels, were generally deemed less important than surface project elements with respect to overall potential project impacts. The importance factors for each project element are shown in Table 6-27.

Table 6-27. Project Element Importance Factors

Project Element	Importance Factors (Percent)
JWPCP Shaft Site	25
Onshore Tunnel Alignment	15
Intermediate Shaft Site	25
Offshore Alignment	10
Diffuser Area	25

Viability Alternative Scoring

To determine an aggregate score for each alternative, the project elements were first scored with respect to the screening parameters, and the importance factors were applied. The results were then multiplied by the screening parameter weights and totaled. The aggregate scores for the viable alternatives are presented in Table 6-28, along with the relative rankings.

The scores reflect the relative superiority of the modified ocean discharge alternatives (the last four alternatives listed in Table 6-28), particularly with respect to environmental impacts, public support, and cost. The lower, closely grouped scores for the new ocean discharge alternatives (the first six alternatives listed in Table 6-28) reflect the tradeoffs between siting a shaft site within the Port of Los Angeles or Angels Gate Park and constructing a diffuser on the SP Shelf or the PV Shelf. For example, the public strongly opposes siting any kind of shaft at Angels Gate Park and prefers a new diffuser area on the SP shelf because it would be further offshore and deeper than a new diffuser area on the PV Shelf. However, a diffuser area on the SP Shelf would be very difficult to construct and expensive given its distance offshore.

Table 6-28. Viable Alternatives Scoring Summary

Alternative	Aggregate Weighted Score	Relative Ranking
Wilmington – LAXT – SP Shelf	5.63	5
Frigate – LAXT – SP Shelf	5.55	6
Wilmington – LAXT – PV Shelf	5.43	8
Frigate – LAXT – PV Shelf	5.36	10
Figueroa – Angels Gate – PV Shelf	5.48	7
N Gaffey – Angels Gate – PV Shelf	5.42	9
Figueroa – Harbor Regional Park – N Gaffey – Capitol – Western	7.56	1
Figueroa – John S Gibson – Capitol – Western	7.49	2
Figueroa – Harbor Regional Park – Navy Fuel Depot – Western	7.47	3
Lomita – Western	7.39	4

Selecting Feasible Alternatives

There are a number of potential approaches to using the scoring as a way to rank the viable alternatives and select those to carry forward as feasible alternatives. The simplest approach would be to rank alternatives based strictly on the scoring, with the highest score ranked as number one and the lowest ranked as number ten, as presented in Table 6-28.

With this approach, the top three or four alternative scores could be used to determine the feasible alternatives. However, there was no clear delineation between the higher and lower ranked alternatives for a new ocean discharge system, and selecting only the alternatives for a modified ocean discharge system would not constitute a reasonable range of alternatives, as required for environmental review under the California Environmental Quality Act (CEQA) and National Environmental Policy Act (NEPA).

A sensitivity analysis was performed in which the screening parameter weights were varied. This analysis indicated that the ten viable alternatives could be logically divided into four distinct groups based on the intermediate shaft site and the diffuser location. The three groups within the new ocean discharge system are LAXT to SP Shelf, LAXT to PV Shelf, and Angels Gate to PV Shelf. The fourth group would consist of the modified ocean discharge alternatives, which would have a shaft site at Royal Palms Beach

and would utilize the existing ocean outfalls. The grouping of the viable alternatives is shown in Table 6-29.

Table 6-29. Grouping of Viable Alternative by Intermediate Shaft Site and Diffuser Location

Program Alternative	Intermediate Shaft Site and Diffuser Area	Project Alternative	Aggregate Score	Relative Ranking Within Grouping
New Ocean Discharge System	LAXT to SP Shelf	Wilmington – LAXT – SP Shelf	5.63	1
		Frigate – LAXT – SP Shelf	5.55	2
	LAXT to PV Shelf	Wilmington – LAXT – PV Shelf	5.43	1
		Frigate – LAXT – PV Shelf	5.36	2
	Angels Gate to PV Shelf	Figueroa – AG – PV Shelf	5.48	1
		N Gaffey – AG – PV Shelf	5.42	2
Modified Ocean Discharge System	Royal Palms to Existing Ocean Outfalls	Figueroa – Harbor Regional Park – N Gaffey – Capitol – Western	7.56	1
		Figueroa – John S Gibson – Capitol – Western	7.49	2
		Figueroa – Harbor Regional Park – Navy Fuel Depot – Western	7.47	3
		Lomita – Western	7.39	4

In all four of these groups, one alternative always ranked highest in the sensitivity analysis, regardless of the screening criteria weights. These top-ranked alternatives are the feasible project alternatives (shown on Figure 6-14).

6.3.4.3 Ranked Feasible Alternatives

On the basis of the analysis performed, the ranked feasible project alternatives, listed from highest to lowest ranking, are:

- **JE 3 (Figueroa – Harbor Regional Park – North Gaffey – Capitol – Western – Royal Palms – Existing Ocean Outfalls):** JWPCP West (working shaft); beneath Figueroa Street, Harbor Regional Park, North Gaffey Street, Capitol Drive, and Western Avenue (through Dodson Avenue); to Royal Palms Beach (exit shaft); and rehabilitation of the existing ocean outfalls
- **JE 2A (Wilmington – LAXT – SP Shelf):** JWPCP East (working shaft); beneath Wilmington Boulevard to the Port of Los Angeles (access shaft at TraPac; construction shaft at LAXT); out through Southwest Marine (access shaft); to diffuser area on SP Shelf; and rehabilitation of the existing ocean outfalls
- **JE 2B (Figueroa – Angels Gate – PV Shelf):** JWPCP West (working shaft); beneath Figueroa Street and South Gaffey Street to Angels Gate Park (access shaft); to diffuser area on PV Shelf; and rehabilitation of the existing ocean outfalls
- **JE 2C (Wilmington – LAXT – PV Shelf):** JWPCP East (working shaft); beneath Wilmington Boulevard to the Port of Los Angeles (access shaft at TraPac; construction shaft at LAXT); out through Southwest Marine (access shaft); to diffuser area on PV Shelf; and rehabilitation of the existing ocean outfalls

A summary of the JOS project-level alternatives analysis is shown on Figure 6-15.

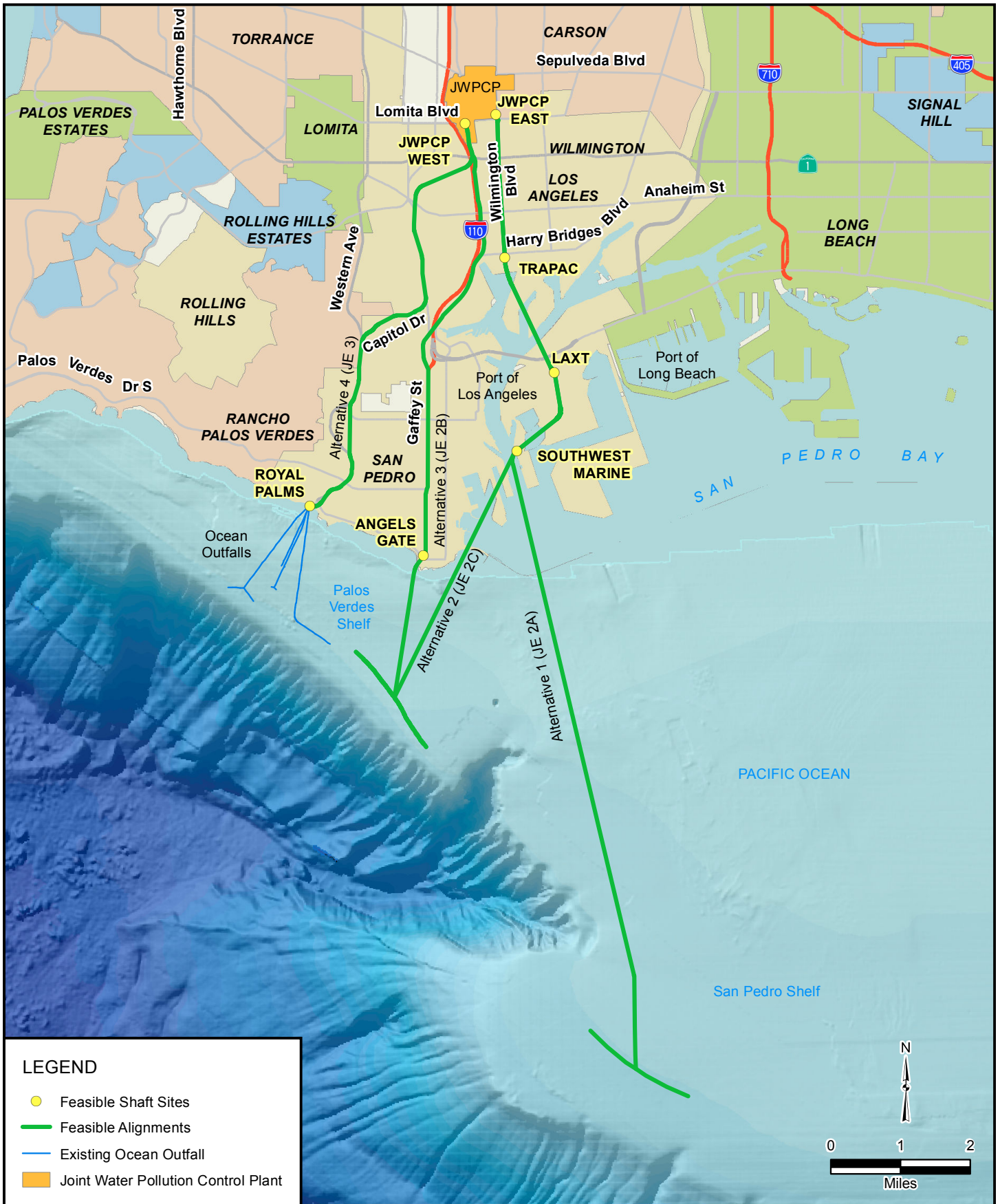

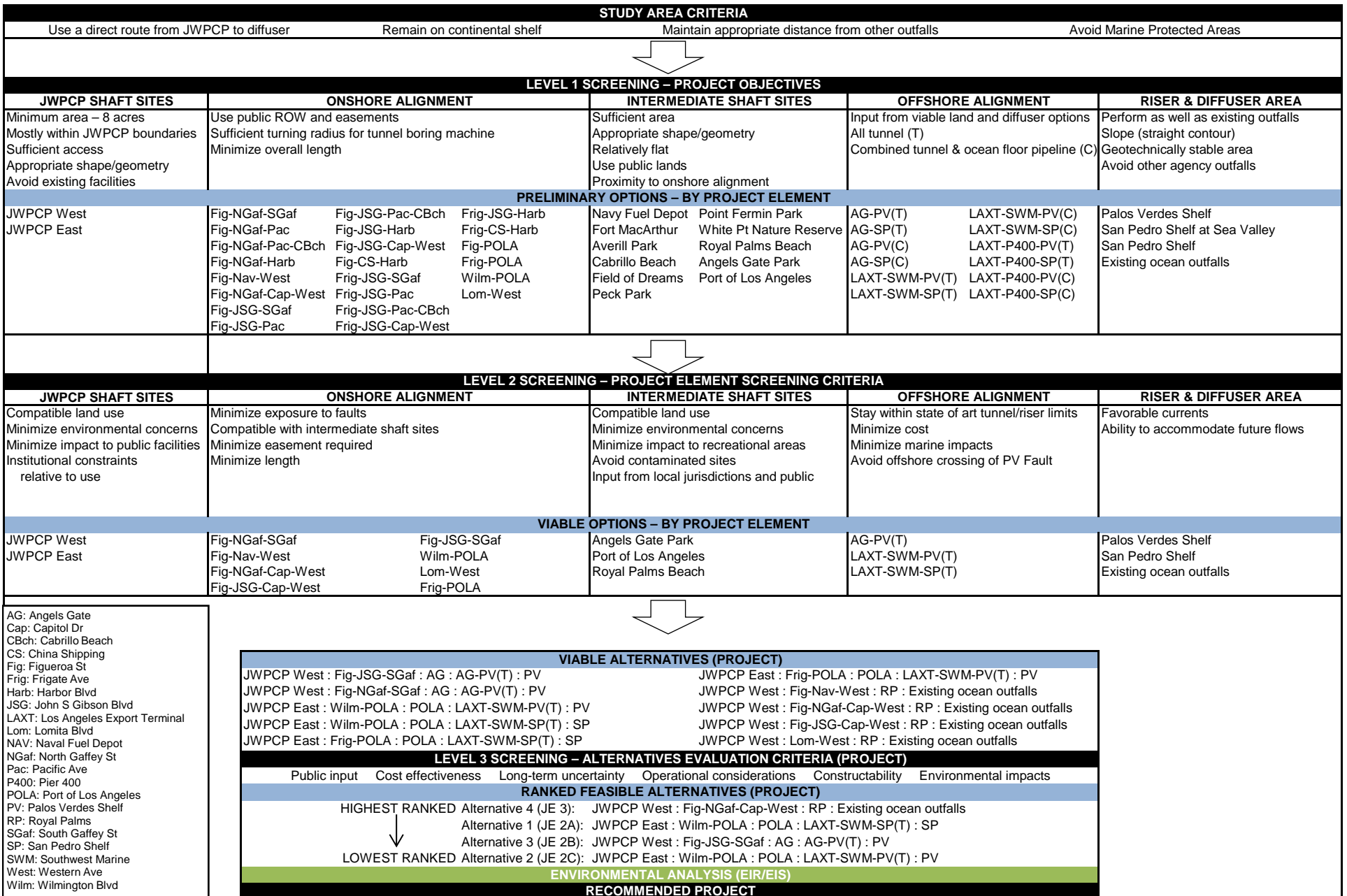

FIGURE 6-15

6.4 Final Plan Alternatives

6.4.1 Viable Alternatives

In Section 6.2, the program component areas were analyzed, and four of the program component areas resulted in one feasible option. They are:

- **Wastewater Conveyance and Treatment – CT 2A:** Expansion at the SJCWRP; Process Optimization at the SJCWRP, POWRP, LCWRP, and LBWRP; and Additional Conveyance Capacity
- **Solids Processing – SP 1A:** Centralized Processing at the JWPCP/Use of Existing Systems
- **Biosolids Management – BM 1:** Current Practices: Beneficial Use/Landfill
- **WRP Effluent Management – WE 1:** Use of Current Effluent Management Systems

Analysis of the fifth program component area, JWPCP effluent management, resulted in two feasible options that were analyzed at a project level in Section 6.3:

- **JWPCP Effluent Management – JE 2:** New Ocean Discharge System
- **JWPCP Effluent Management – JE 3:** Modified Ocean Discharge System

The results of this analysis provided a set of four ranked feasible project alternatives (listed from highest to lowest ranking):

- **Modified Ocean Discharge System – JE 3:** Figueroa – Harbor Regional Park – North Gaffey – Capitol – Western – Royal Palms – Existing Ocean Outfalls
- **New Ocean Discharge System – JE 2A:** Wilmington – LAXT – SP Shelf
- **New Ocean Discharge System – JE 2B:** Figueroa – Angels Gate – PV Shelf
- **New Ocean Discharge System – JE 2C:** Wilmington – LAXT – PV Shelf

Combining the program and project elements into a set of system wide alternatives results in four feasible plan alternatives, which are listed in Table 6-30 and shown on Figure 6-2.

Table 6-30. Feasible Plan Alternatives

Alternative	Component Areas	Relative Ranking
1	CT 2A – SP 1A – BM 1 – WE 1 – JE 2A	2
2	CT 2A – SP 1A – BM 1 – WE 1 – JE 2C	4
3	CT 2A – SP 1A – BM 1 – WE 1 – JE 2B	3
4	CT 2A – SP 1A – BM 1 – WE 1 – JE 3	1

6.4.1.1 Cost of Feasible Alternatives

The capital cost to implement each of the four feasible plan alternatives is shown in Table 6-31.

Table 6-31. Capital Costs for Feasible Plan Alternatives

Component Area	Alternative 1	Alternative 2	Alternative 3	Alternative 4
Wastewater Conveyance and Treatment	\$658M	\$658M	\$658M	\$658M
Solids Processing	\$66M	\$66M	\$66M	\$66M
Biosolids Management	\$0M	\$0M	\$0M	\$0M
WRP Effluent Management	\$0M	\$0M	\$0M	\$0M
JWPCP Effluent Management ^a	\$1,362M	\$984M	\$909M	\$550M
Total:	\$2,086M	\$1,708M	\$1,633M	\$1,274M

^a Includes \$15 million to rehabilitate the existing ocean outfalls.
M = million

6.4.2 No-Project and No-Federal-Action Alternatives

Environmental reviews (CEQA and NEPA) associated with new facilities require the inclusion of no-project and no-federal-action alternatives as a basis for comparison in the evaluation of the environmental impacts for the recommended facilities.

Under the No-Project Alternative for the Clearwater Program, it is assumed that the recommendations for WRP expansion, conveyance system improvements, WRP effluent management, solids processing, and biosolids management from the previous comprehensive JOS facilities planning effort (JOS 2010 Master Facilities Plan) would be implemented when needed. There would be no process optimization at the WRPs and a new or modified ocean discharge system would not be constructed. Under this approach, project objectives previously outlined would not be achieved, so it is not considered feasible.

Under the No-Federal-Action Alternative, it is assumed that no federal permits would be issued for any of the recommendations of the Clearwater Program. The only aspect of the Clearwater Program that requires federal permits is the construction of a new or modified ocean discharge system. Therefore, under this alternative, all of the conveyance/treatment, solids processing, biosolids management, and WRP effluent management recommendations of the Clearwater Program would be implemented, but there would be no new or modified ocean discharge system. Under this approach, project objectives previously outlined would not be achieved, so it is not considered feasible.

6.4.3 Identification of Recommended Plan

The four plan alternatives consist of program and project aspects. Because the alternatives are identical in all aspects except for the selected approach to JWPCP effluent management, the ranking of the feasible project alternatives, shown in Section 6.3.4.3, represents the ranking of the plan alternatives. Therefore, Alternative 4 from Table 6-30 is the recommended plan alternative. The program and project elements of the recommended plan are:

- **Wastewater Conveyance and Treatment – CT 2A:** Expansion at the SJCWRP; Process Optimization at the SJCWRP, POWRP, LCWRP, and LBWRP; and Additional Conveyance Capacity
- **Solids Processing – SP 1A:** Centralized Processing at the JWPCP
- **Biosolids Management – BM 1:** Current Practices: Beneficial Use/Landfill
- **WRP Effluent Management – WE 1:** Use of Current Effluent Management Systems
- **JWPCP Effluent Management – JE 3:** Figueroa – Harbor Regional Park – North Gaffey – Capitol – Western – Royal Palms (JWPCP West [working shaft]; Beneath Figueroa Street,

Harbor Regional Park, North Gaffey Street, Capitol Drive, and Western Avenue [through Dodson Avenue]; to Royal Palms Beach [exit shaft]); and Rehabilitation of the Existing Ocean Outfalls

The specifics of the recommended plan are described in more detail within Chapter 7.

Chapter 7

RECOMMENDED PLAN SUMMARY

7.1 Introduction

Based on the alternatives analysis presented in Chapter 6, the recommended plan for the Clearwater Program is a combination the highest-ranked feasible program alternatives for each of the Joint Outfall System (JOS) component areas and the highest-ranked feasible project alternative (Alternative 4) for effluent management at the Joint Water Pollution Control Plant (JWPCP). Chapter 7 presents a detailed description of the facilities needed to implement the recommended plan. Given the speculative nature of the program, which would be implemented over the long term, the emphasis of this chapter is on the recommended project – a modified ocean discharge system.

This chapter is organized into the following major sections:

- Summary of the Recommended Plan
- Plan Implementation and Schedule
- Project Cost
- Revenue Program
- Project Financing

7.2 Summary of the Recommended Plan

Program recommendations, which are broad and long term, would be implemented as needed. Project recommendations, which require a greater level of detail, would be implemented in the short term.

The five major program component areas are:

- Wastewater conveyance and treatment
- Solids processing
- Biosolids management
- Water reclamation plant (WRP) effluent management
- JWPCP effluent management

The four component areas with recommended program-level improvements are wastewater conveyance and treatment, solids processing, biosolids management, and WRP effluent management. The one component area with recommended project-specific improvements is JWPCP effluent management.

7.2.1 Wastewater Conveyance and Treatment

Recommendations for the conveyance and treatment program component area of the recommended plan include a 25 million gallons per day (MGD) expansion at the San Jose Creek Water Reclamation Plant (SJCWRP); process optimization at the Pomona Water Reclamation Plant (POWRP), SJCWRP, Los Coyotes Water Reclamation Plant (LCWRP), and Long Beach Water Reclamation Plant (LBWRP); and approximately 32.5 miles of relief sewers within the JOS. Process optimization consists of modifications within the existing plants to ensure that the Sanitation Districts of Los Angeles County (Sanitation Districts) continue to consistently meet permit conditions in anticipation of increasing regulatory requirements. Process optimization construction activities include flow equalization through the addition of storage capacity; treatment system modifications, as well as ancillary support facilities; and other in-plant upgrades.

7.2.1.1 Pomona Water Reclamation Plant

The POWRP would be upgraded to include flow equalization of the primary effluent, as shown on Figure 7-1. The flow equalization volume required for the POWRP is approximately 20 percent of the plant's daily permitted flow of 15 MGD. Therefore, the recommended equalization volume is 3 million gallons (MG). Based on a unit cost of \$4 per gallon of storage, the total capital cost associated with the flow equalization facilities at the POWRP is approximately \$12 million.

The current POWRP property boundary is large enough to accommodate the process optimization facilities, so additional land would not be required. Process optimization would likely be implemented between 2018 and 2028 depending on future flows, recycled water demands, regulatory requirements, and funding considerations.

7.2.1.2 San Jose Creek Water Reclamation Plant

Based on the wastewater flow projections presented in Chapter 4 and the assessment of current capabilities relative to future needs presented in Chapter 5, approximately 20 MGD of additional treatment plant capacity is required for the JOS by the 2050 planning horizon. As concluded by the alternatives analysis presented in Chapter 6, the SJCWRP is the most suitable location for a treatment plant expansion of at least 20 MGD. Therefore, the recommended plan calls for the SJCWRP to be expanded from its current permitted capacity of 100 MGD to 125 MGD. This 25-MGD expansion consists of the addition of two 12.5-MGD treatment modules that are consistent with the existing modules at the SJCWRP. The design criteria for the SJCWRP expansion is provided in Appendix C. Based on a unit cost of \$8 per gallon of wastewater treated, the total capital cost associated with the 25-MGD wastewater treatment facilities expansion is approximately \$200 million.

The current SJCWRP property boundary is large enough to accommodate the recommended wastewater treatment facilities expansion. Consequently, construction of the facilities would not require acquisition of additional land. Based on wastewater flow projections, SJCWRP expansion would likely be implemented between 2040 and 2050. The locations of the recommended treatment facilities are shown on Figure 7-2.

In addition to a 25-MGD expansion, the SJCWRP would be upgraded to include flow equalization of the primary effluent. The flow equalization volume required for the SJCWRP is approximately 25 percent of the plants' expanded daily permitted flow of 125 MGD. Therefore, the recommended equalization volume is 31 MG. Based on a unit cost of \$4 per gallon of storage, the total capital cost associated with 31 MG of flow equalization facilities at the SJCWRP is approximately \$125 million.



FIGURE 7-1



FIGURE 7-2

**San Jose Creek Water Reclamation Plant
Proposed Facilities**



Source: Sanitation Districts of Los Angeles County 2011, LARIAC 2007

The current SJCWRP property boundary is large enough to accommodate the process optimization facilities, so additional land would not be required. Process optimization would likely be implemented between 2018 and 2028, depending on future flows, recycled water demands, regulatory requirements, and funding considerations. The location of the recommended process optimization facilities is shown on Figure 7-2.

7.2.1.3 Los Coyotes Water Reclamation Plant

The LCWRP would be upgraded to include flow equalization of the primary effluent, as shown on Figure 7-3. The flow equalization volume required for the LCWRP is approximately 20 percent of the plant's daily permitted flow of 37.5 MGD. Therefore, the recommended equalization volume is 7.5 MG. Based on a unit cost of \$4 per gallon of storage, the total capital cost associated with the flow equalization facilities at the LCWRP is approximately \$30 million.

The current LCWRP property boundary is large enough to accommodate the process optimization facilities, so additional land would not be required. Flow equalization facilities can be built under the existing driving range for the Iron-Wood Nine Golf Course, thus not impacting its long-term use. Process optimization would likely be implemented between 2018 and 2028, depending on future flows, recycled water demands, regulatory requirements, and funding considerations.

7.2.1.4 Long Beach Water Reclamation Plant

The LBWRP would be upgraded to include flow equalization of the primary effluent, as shown on Figure 7-4. The flow equalization volume required for the LBWRP is approximately 20 percent of the plant's daily permitted flow of 25 MGD. Therefore, the recommended equalization volume is 5 MG. Based on a unit cost of \$4 per gallon of storage, the total capital cost associated with the flow equalization facilities at the LBWRP is approximately \$20 million.

The current LBWRP property boundary is large enough to accommodate the process optimization facilities, so additional land would not be required. Process optimization would likely be implemented between 2018 and 2028, depending on future flows, recycled water demands, regulatory requirements, and funding considerations.

7.2.1.5 Conveyance System

Based on the projected wastewater flows for the year 2050 and a 25-MGD expansion at the SJCWRP, approximately 32.5 miles of Joint Outfall (JO) relief trunk sewers would be required during the planning period. The Sanitation Districts would continue to closely monitor the JOS conveyance system throughout the planning period to determine actual relief needs. The future conveyance system improvement projects, which would be implemented on an as-needed basis, are graphically depicted on Figure 7-5. Based on a unit cost of \$30 per inch-diameter per linear foot, the total capital cost associated with the conveyance system improvements is approximately \$271 million.

7.2.2 Solids Processing

The recommended plan is to continue centralized solids processing at the JWPCP using existing systems. Sludges generated at the upstream WRPs would continue to be returned to the conveyance system and removed and treated at the JWPCP.



FIGURE 7-3

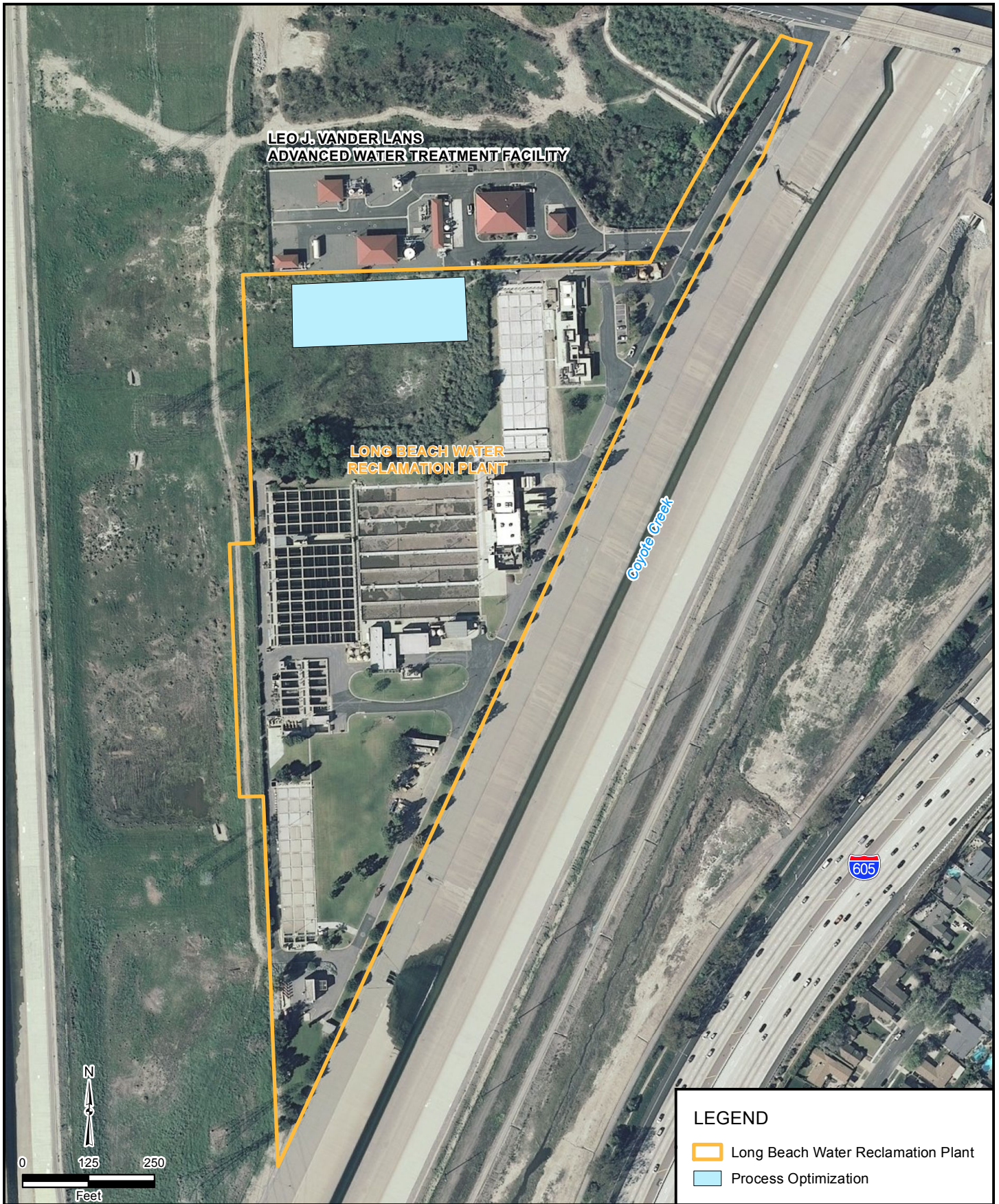

FIGURE 7-4



FIGURE 7-5

7.2.2.1 Sludge Thickening

The capacity of the existing dissolved air flotation thickener system at the JWPCP is anticipated to be sufficient to meet the projected needs for 2050. Therefore, no additional thickening systems would be required over the duration of the planning period.

7.2.2.2 Sludge Stabilization

Based on the solids projections presented in Chapter 4 and the needs assessment presented in Chapter 5, additional sludge stabilization capacity would be required at the JWPCP. It is anticipated that the additional capacity would be in the form of units of similar design to those currently existing. Based on this assumption, six additional anaerobic digesters would be required by 2050. The total capital cost associated with the sludge stabilization facilities expansion is approximately \$66 million.

The current JWPCP property boundary is large enough to accommodate the six additional digesters, so additional land would not be required. The location for the new digesters is shown on Figure 7-6. The timing for digester construction is dependent on future trending of sludge production at the JWPCP.

7.2.2.3 Sludge Dewatering

The capacity of the existing sludge dewatering system is anticipated to be sufficient to meet the projected future digested sludge flow for 2050. Therefore, no additional sludge dewatering facilities would be required over the duration of the planning period. The Sanitation Districts would continue the existing program of replacing aging centrifuges as needed throughout the duration of the planning period.

7.2.2.4 Digester Gas Handling and Power Generation

The power plant at the JWPCP currently utilizes two turbines that run on digester gas, a third turbine that is used for standby, four boilers that create steam from digester gas for process heating, and twelve flares that burn excess digester gas. Additional gas resulting from an increased number of digesters would be managed by these facilities. The turbines are currently supplemented with natural gas. As digester gas increases, it would be used in lieu of natural gas.

7.2.3 Biosolids Management

The recommended plan for biosolids management is the continuation of current practices. During the planning period, it is projected that the JOS biosolids generation rate would increase nearly 30 percent. The Sanitation Districts currently have a robust and diverse system in place to address the projected increase. The Sanitation Districts also have the ability to co-dispose biosolids in landfills, but this option would become more restrictive with the scheduled closure of the Puente Hills Landfill in 2013. However, the Westlake Farms Composting Facility should begin operations by the same year, and can be expanded in phases if and when future needs arise. Therefore, it is anticipated that there is no additional physical infrastructure required to accommodate future biosolids management. The Sanitation Districts would continue to explore options that provide for additional biosolids management diversity and further optimize the beneficial use of these materials.

7.2.4 WRP Effluent Management

The recommended plan for WRP effluent management is the continuation of existing practices. The existing system of WRP effluent management is effective and provides the Sanitation Districts flexibility



FIGURE 7-6

with respect to providing recycled water for reuse and discharging any excess flows to surface waterways. While the amount of reuse is likely to increase in the future, surface water discharge capabilities would be retained.

7.2.5 JWPCP Effluent Management (Project)

The recommend plan for JWPCP effluent management includes a project to modify the existing ocean discharge system (Alternative 4 from Chapter 6). Project elements comprise a working shaft site at the JWPCP, an onshore tunnel between the JWPCP and the existing ocean outfall manifold structure at Royal Palms Beach near White Point, an exit shaft site at Royal Palms Beach, and the rehabilitation of the existing ocean outfalls. Overall, it is anticipated that the project would take approximately 6.5 years to construct. The new tunnel, when connected to the existing ocean outfalls, would have a maximum hydraulic capacity of approximately 1,080 MGD, which can accommodate the peak storm flows of 927 MGD projected for the year 2050. Therefore, upon completion of the recommended project, the two existing effluent tunnels could be dewatered, inspected, and repaired or rehabilitated as necessary.

7.2.5.1 JWPCP West Shaft Site

The JWPCP West shaft site would be located mostly within the JWPCP property boundary on approximately 18 acres to the south and 1 acre to the north of Lomita Boulevard near Figueroa Street in the cities of Los Angeles and Carson as shown on Figure 7-7. The JWPCP West shaft site would function as a working shaft site and would be used throughout the duration of the project for site preparation, mobilization, shaft construction, staging and support for tunnel construction, and connection to the existing JWPCP effluent force main. The shaft would serve as the entry/exit point for construction workers, tunnel materials (e.g., liner segments), and equipment and the exit point for all of the excavated material. If needed, a noise barrier, approximately 20 feet in height, would be erected between the major sources of noise at the shaft site and nearby sensitive receptors. It is anticipated that the shaft itself would be constructed in the northern half of the 18-acre portion of the site. Access to the shaft site would likely occur from Figueroa Street via Lomita Boulevard, Pacific Coast Highway, or Sepulveda Boulevard.

The shaft depth would be approximately 140 feet below ground surface, and the shaft diameter would be about 40 to 60 feet. The shaft profile is shown in Figure 7-8. Shaft construction would take about 10 to 12 months. Upon completion of the tunneling activities, the shaft would be converted into a drop structure and connected to the existing JWPCP effluent force main, located within the 1-acre portion of the site. This connection would likely either be tunneled or jacked under Lomita Boulevard. Approximately 0.5 acre would be required at the shaft site for permanent aboveground facilities, which would include a ground-level concrete lid over the shaft, a surge tower, vent pipes, access lids, and possibly a pumping plant.

7.2.5.2 Figueroa – Harbor Regional Park – North Gaffey – Capitol – Western Tunnel Alignment

The recommended tunnel alignment, as shown on Figure 7-9, would begin at the JWPCP West shaft site, continue approximately 2,600 feet south under Figueroa Street, approximately 6,000 feet southwest under Harbor Regional Park, approximately 8,000 feet south under North Gaffey Street, approximately 5,300 feet southwest under Capitol Drive, approximately 5,200 feet south under Western Avenue, approximately 4,000 feet south under South Dodson Avenue, and approximately 5,500 feet southwest under Western Avenue to the Royal Palms shaft site for a total distance of approximately 36,600 feet, or 6.9 miles. The tunnel would terminate adjacent to the existing ocean outfall manifold structure at Royal Palms Beach.



FIGURE 7-7

JWPCP West Shaft Site

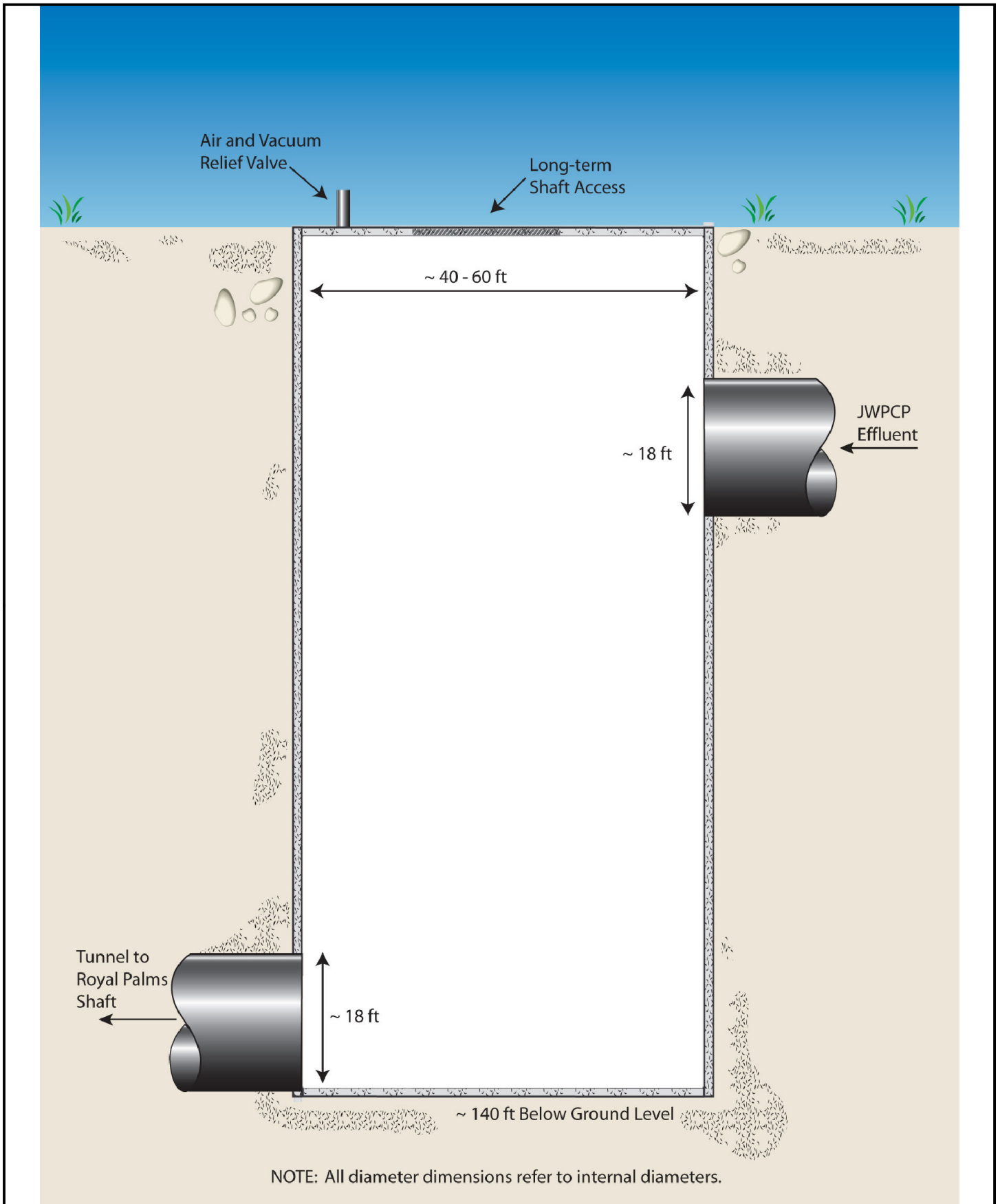

FIGURE 7-8

JWPCP West Shaft Profile

Source: Sanitation Districts of Los Angeles County 2011

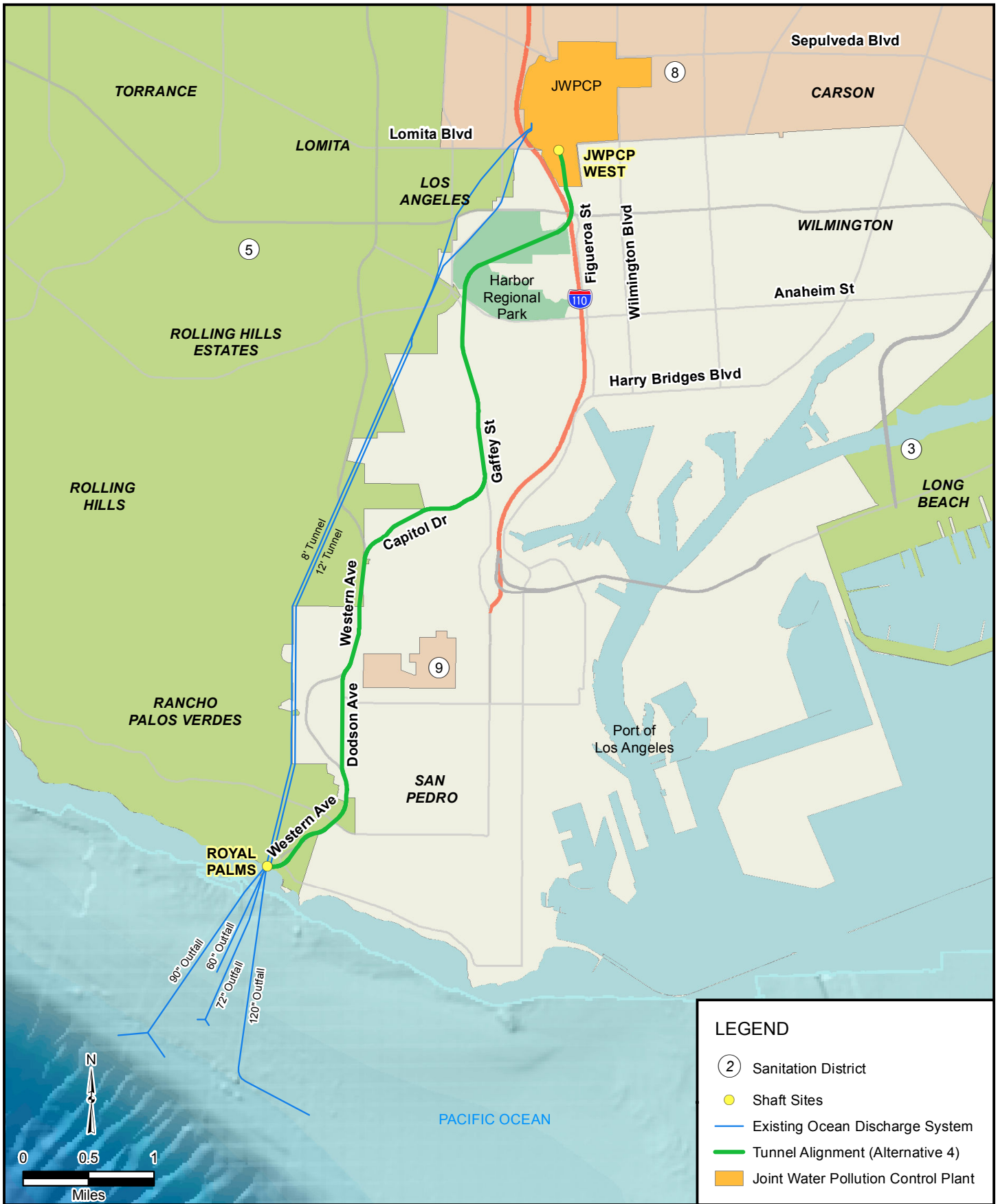

FIGURE 7-9

The tunnel would be constructed with a tunnel boring machine (TBM). The TBM, which would be placed underground at the JWPCP West shaft site, would be capable of excavating soil/rock and installing a tunnel liner as it advances. The excavated material would be removed for disposal or, possibly, beneficial use. Tunneling is expected to advance at an average rate of 35 feet per day through soil and an average rate of 40 feet per day through rock. Tunnel construction for this alignment would take approximately 4 years.

The tunnel depth at tunnel crown would range from approximately 70 to 450 feet below ground surface, except for where the tunnel alignment would connect to the Royal Palms shaft (approximately 30 feet below ground surface). The tunnel would have an excavated diameter of approximately 20 to 22 feet and an internal finished diameter of approximately 18 feet. The tunnel would be constructed of pre-fabricated, steel-reinforced concrete liner segments with watertight gaskets.

Tunnel construction would require mobilization of various support equipment for activities such as assembly of the TBM and trailing gear; operation of the tunnel ventilation system; and movement of workers, materials, and equipment between the ground surface and the bottom of the shaft.

Either an earth-pressure balance (EPB) TBM or a slurry TBM would be utilized on this project. The primary difference between the two TBM types is how the excavated material generated from the tunneling operation is removed. With an EPB TBM, specialized locomotives would convey the excavated material in rail cars back through the constructed portion of the tunnel to the JWPCP West shaft for removal by crane. The excavated material would be retained at the surface to allow any water to separate before removal. With a slurry TBM, the excavated material would be blended with a slurry mixture (such as bentonite clay and water) and pumped back through the constructed portion of the tunnel to the ground surface at the JWPCP West shaft. The excavated material and slurry mixture would be processed at a temporary slurry separation plant, located at the shaft site, which extracts the slurry for reuse. The type of TBM would not be specified until completion of final design.

7.2.5.3 Royal Palms Shaft Site

The Royal Palms shaft site would be located mostly within Sanitation Districts-owned property surrounding the existing ocean outfall manifold structure on approximately 1 acre at Royal Palms Beach near the access road off of West Paseo Del Mar as shown on Figure 7-10. The Royal Palms shaft site would function as an exit shaft site for removal of the TBM upon tunnel completion. The shaft site would also be used to connect the new tunnel to the existing ocean outfalls at the manifold structure.

The shaft depth would be approximately 50 feet below ground surface, and the shaft diameter would be about 25 to 35 feet. The shaft profile is shown in Figure 7-11. Shaft construction would take approximately 6 to 9 months. A noise barrier, approximately 20 feet in height, would be erected between the major sources of noise at the shaft site and nearby sensitive receptors.

A new underground manifold structure would be constructed next to the shaft to facilitate the connections between the tunnel and the existing ocean outfalls. Valves would be installed to control the amount of effluent flow to each of the outfalls and to allow for isolation of the new tunnel between the Royal Palms and JWPCP West shaft sites. The interconnection work would take approximately 1.5 years.

After construction, the beach parking area would be restored to its original configuration. There would be no permanent aboveground facilities at the shaft site, except a ground-level concrete lid over the shaft and new manifold structure, vent pipes, and access lids. A permanent access easement of approximately 0.1 acre would be needed for future operation and maintenance activities.



FIGURE 7-10

Royal Palms Shaft Site

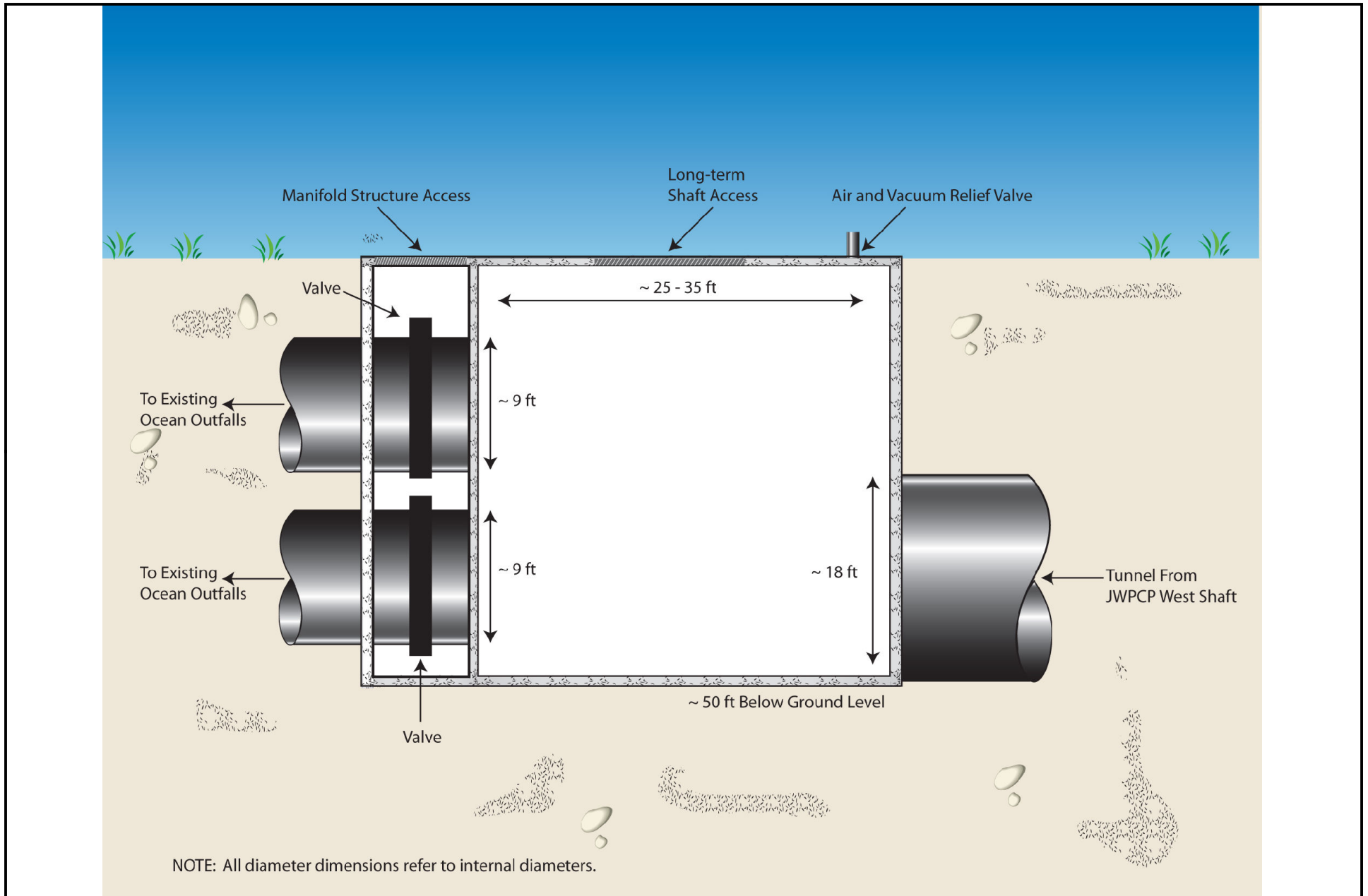

FIGURE 7-11

7.2.5.4 Existing Ocean Outfall Rehabilitation

Under the recommended plan, JWPCP effluent would continue to be discharged through the existing ocean outfalls. The recommended plan would include rehabilitation of the three largest existing ocean outfalls and abandonment of the 60-inch outfall. Re-ballasting work would occur on the existing 72-, 90-, and 120-inch outfalls in ocean depths ranging from approximately 20 to 50 feet. Joint repairs would involve temporarily removing some of the existing ballast rock from around the outfalls to fully expose the joint being repaired. A coupling would be installed around the joint and the annular space filled with concrete, and the ballast rock would be replaced around the pipe. Cathodic protection would be restored or added as necessary. Overall, the rehabilitation work, including mobilization, construction, and demobilization, would take approximately 9 months. Once rehabilitated, it is anticipated that the three existing ocean outfalls would have a remaining service life that extends well beyond the 2050 planning horizon. (Parsons 2011)

7.3 Plan Implementation and Schedule

The program-level components of the recommended plan would be implemented as necessary during the planning period. Process optimization improvements at the POWRP, SJCWRP, LCWRP, and LBWRP would likely occur between 2018 and 2028 but are contingent on actual future flows, recycled water demands, regulatory requirements, and funding considerations. Similarly, the conveyance system relief projects and the six digesters at the JWPCP would be constructed on an as-needed basis. Based on wastewater flow projections, the 25-MGD expansion at the SJCWRP would be implemented between 2040 and 2050. If the actual flows materialize later than anticipated, the construction of the recommended facilities would be delayed accordingly. Likewise, if the actual flows materialize sooner than anticipated, the construction of the recommended facilities would be accelerated accordingly.

The estimated implementation schedule for the modified ocean discharge system is summarized in Table 7-1. The actual schedule could vary depending on permitting, right-of-way and land acquisition, final design, funding, and construction considerations. Project construction is scheduled from early 2015 to mid-2021, a total duration of approximately 6.5 years.

Table 7-1. Implementation Schedule for Modified Ocean Discharge System

	2012	2013	2014	2015	2016	2017	2018	2019	2020	2021
Permitting and Easement/Land Acquisition		■								
Final Design, Advertise, Bid, and Award		■								
Submittals and TBM Fabrication				■						
JWPCP West Shaft Construction				■						
Site Preparation/TBM Assembly					■					
Tunneling						■				
Royal Palms Shaft Construction and Interconnection								■		
Existing Ocean Outfalls Rehabilitation								■		

7.4 Project Cost

The total capital cost and equivalent annual capital cost for the modified ocean discharge system are presented in Table 7-2. Although the project cost would be incurred over multiple years in the future, all amounts shown in Table 7-2 are in 2011 dollars and include design, construction, and project

management. The anticipated total project cost, in 2021 dollars (at the end of construction, when repayment of long-term financing would commence) is approximately \$739,000,000.

Table 7-2. Capital and Annualized Capital Cost Breakdown of the Recommended Project^{a,b}

Project Element	Total
JWPCP West Shaft Site	\$33,000,000
Tunnel (Figueroa – Harbor Regional Park – North Gaffey – Capitol – Western)	\$478,000,000
Royal Palms Shaft Site	\$24,000,000
Existing Ocean Outfalls Rehabilitation	\$15,000,000
Total Capital Costs	\$550,000,000
Equivalent Annual Capital Cost ^c	\$37,000,000

^a 2011 dollars.
^b All costs include design support, construction, and project management.
^c Amortized at a 3-percent annual interest rate for 20 years.

7.4.1 Upgrade and Expansion Costs

For funding purposes, the capital cost of the recommended project has been split into two subcategories: upgrade and expansion. Upgrade portions of the project benefit existing users by addressing needed improvements or existing deficiencies without providing additional capacity. Expansion portions of the project benefit new users by providing increased capacity to accommodate their discharge. For the purposes of this financial analysis, the upgrade portion is based on the peak wet weather plant flow associated with current average daily flow. The expansion portion is based on the additional capacity above and beyond current peak wet weather flows.

As discussed in the previous chapters, the two existing JWPCP effluent tunnels are critical components of the existing JOS ocean discharge system. Neither of the tunnels has been inspected in over 50 years, and one of the tunnels has been in service for over 70 years. Inspection of the tunnels is not possible due to their overall length, limited access, lack of hydraulic separation between the tunnels, and the large quantity of daily effluent flow through the tunnels. For the same reasons, repair and rehabilitation of these tunnels, should it be warranted, is not possible. Furthermore, both tunnels cross an active seismic fault (the Palos Verdes Fault), but neither was constructed to modern day seismic standards and neither has been retrofitted since being built. The recommended project would provide a redundant effluent tunnel with the capacity to accommodate all current flows to the JWPCP, thus allowing the existing tunnels to be taken out of service and dewatered as needed for inspection and rehabilitation/repair. The recommended project would also increase the hydraulic capacity of the ocean discharge system by approximately 25 percent, which would accommodate the projected peak storm flows through the year 2050.

Therefore, with the exception of the existing ocean outfall rehabilitation, all elements of the recommended project should be allocated at a 3:1 ratio between upgrade and expansion, respectively. Because the rehabilitation of the existing ocean outfall would not provide any additional capacity, 100 percent of the cost associated with this project element should be attributed to upgrade. As shown in Table 7-3, of the recommended project's \$550,000,000 total estimated capital cost, \$416,250,000 is attributable to upgrade and \$133,750,000 is attributable to expansion.

Table 7-3. Capital Cost of Upgrade and Expansion Portions of the Recommended Project^{a,b}

Project Element	Upgrade	Expansion	Total
JWPCP West Shaft Site	\$24,750,000	\$8,250,000	\$33,000,000
Onshore Tunnel	\$358,500,000	\$119,500,000	\$478,000,000
Royal Palms Shaft Site	\$18,000,000	\$6,000,000	\$24,000,000
Existing Ocean Outfalls Rehabilitation	\$15,000,000	-	\$15,000,000
Total Capital Costs	\$416,250,000	\$133,750,000	\$550,000,000

^a 2011 dollars.
^b All costs include design support, construction, and management.

The upgrade portion of the recommended project does not provide additional capacity to the ocean discharge but, instead, addresses the aging infrastructure concerns regarding key system elements. Consequently, the existing users are responsible for paying for the capital costs associated with the upgrades. A portion of the service charge collected from the existing users would ultimately pay for this portion of the recommended project as discussed in the following sections.

The expansion portion of the recommended project would provide additional hydraulic capacity to the ocean discharge system. Consequently, the new users of the system, as well as existing users who significantly increase their discharge flow and/or strength, are responsible for paying the capital costs associated with expansion. The new users would ultimately pay for this portion of the recommended project through connection fees as discussed in the following sections.

7.5 Revenue Program

A major consideration in proposing any capital construction program is the cost and impact it would have on both existing and future users. The Sanitation Districts have developed a comprehensive revenue program to address these issues. In general, this means a program, including appropriate ordinances, to allocate costs and collect revenues as needed from the users of the wastewater management system to ensure sufficient revenues for the construction and subsequent operation of facilities. Specifically, a revenue program must demonstrate that the proposed system of user charges is fair, equitable, and based on both the flow and the strength of the users' discharges. Furthermore, a revenue program must provide that, following completion of construction, there would be a sufficient revenue stream to continue to operate and maintain each facility throughout its useful life. Lastly, a revenue program must provide for the repayment of any long-term financing used to fund the construction of facilities.

The Sanitation Districts first addressed the issue of a revenue program in the May 1979 Report on the Future Revenue Program of the Sanitation Districts of Los Angeles County. This report has been updated numerous times as subsequent facilities plans were submitted to the State Water Resources Control Board (SWRCB) in conjunction with State Revolving Fund (SRF) loan applications. In summary, these reports recommended a revenue program based on maximum utilization of existing sources of revenue, supplemented by revenues from two additional programs: the Service Charge Program and the Connection Fee Program.

7.5.1 Service Charge Program

In fiscal year 1978–79, with the passage of Proposition 13 and the subsequent reduction in ad valorem taxes, the Sanitation Districts' expenses began to exceed available revenues. In order to remain solvent, the Sanitation Districts utilized available cash reserves. These reserves had been accumulated in anticipation of having to construct secondary treatment facilities at the JWPCP. As the Sanitation

Districts were successful in obtaining grant funding for a number of projects, the previously accumulated funds were not needed for the capital construction program and were available for on-going expenses. Although these reserves served to keep the Sanitation Districts solvent in the near term, the Service Charge Program was developed as a long-term solution.

The development of the Service Charge Program was approached from two basic perspectives: charge structure and method of collection. As part of the development process, an extensive public information program was conducted. The key factors stressed by the public were a low administrative cost, a low delinquency factor, and equity for all users. With respect to equity, a point repeatedly voiced by the public was that existing users of the sewerage system should not be required to subsidize new growth. From this latter point came the development of the Connection Fee Program (see Section 7.5.2).

The Service Charge Program, as developed, includes the following provisions:

- Existing users are charged for operations, maintenance, and upgrade capital costs
- Charges are based on the estimated usage of the system (i.e., based on user category with estimated loadings per unit of usage and facility size)
- Charges are based on a combination of flow rate and strength (i.e., chemical oxygen demand [COD] and suspended solids [SS])
- Dischargers may receive a rebate based on demonstrated water usage below the estimated loading of their particular user category
- Charges are collected as specific liens on the property tax bills

The historic, current, and adopted annual service charge rates per sewage unit (equivalent single-family home) are provided in Table 7-4.

Table 7-4. Joint Outfall System Annual Service Charge Rates per Sewage Unit

District ^a	Fiscal Year 2006–07	Fiscal Year 2007–08	Fiscal Year 2008–09	Fiscal Year 2009–10	Fiscal Year 2010–11	Fiscal Year 2011–12	Fiscal Year 2012–13	Fiscal Year 2013–14
1	\$108.75	\$116.00	\$126.00	\$138.00	\$152.00	\$154.00	\$156.00	\$158.00
2	104.50	111.00	121.00	133.00	147.00	148.00	149.00	150.00
3	105.00	112.00	122.00	134.00	148.00	150.00	152.00	154.00
5	95.75	100.00	108.00	118.00	130.00	132.00	134.00	136.00
8	94.00	99.00	109.00	121.00	135.00	139.00	143.00	147.00
15	98.00	103.00	110.00	119.00	130.00	132.00	134.00	136.00
16	101.00	106.00	113.00	122.00	133.00	135.00	137.00	139.00
17	102.00	107.00	114.00	123.00	134.00	136.00	138.00	140.00
18	104.50	112.00	122.00	134.00	148.00	149.00	150.00	151.00
19	103.75	110.00	120.00	132.00	146.00	148.00	150.00	152.00
21	102.50	109.00	119.00	131.00	145.00	146.00	147.00	148.00
22	106.25	113.00	121.00	131.00	143.00	145.00	147.00	149.00
23	79.00	85.00	92.00	101.00	112.00	114.00	116.00	118.00
28 ^b	308.00	308.00	315.00	324.00	335.00	336.00	337.00	338.00

Table 7-4 (Continued)

District ^a	Fiscal Year 2006–07	Fiscal Year 2007–08	Fiscal Year 2008–09	Fiscal Year 2009–10	Fiscal Year 2010–11	Fiscal Year 2011–12	Fiscal Year 2012–13	Fiscal Year 2013–14
28 ^c	100.00	100.00	107.00	116.00	127.00	128.00	129.00	130.00
29	141.75	201.75	261.75	321.75	327.75	333.75	339.75	-
SBC	90.00	92.00	99.00	108.00	119.00	120.00	121.00	122.00

^a Although District No. 34 is a Joint Outfall District, it is currently inactive and, therefore, is not listed.

^b Rate applies to those users who directly connect to the La Cañada Outfall Trunk Sewer or the Foothill Main Trunk Sewer or are in an area tributary to the La Cañada WRP.

^c Rate applies to those users who are within a city of La Cañada Flintridge assessment district.

7.5.2 Connection Fee Program

The Connection Fee Program only applies to new users and existing users who significantly increase their discharge flow and/or strength. This program includes the following provisions:

- New users, or existing users who significantly increase their discharge flow and/or strength, are charged a one-time fee for the incremental cost of expanding capital facilities to accommodate the new or significantly increased discharge
- Charges are based on the anticipated usage of the system (i.e., based on user category and facility size)
- Charges are based on a combination of flow rate and strength (i.e., COD and SS)

The connection fees from new users, or existing users who significantly increase their discharge flow and/or strength, are collected and deposited into a restricted fund designated as the Capital Improvement Fund. As expansion-related projects are constructed, the necessary funds are withdrawn from this account and used to cover the cost of expansion.

The historic, current, and adopted connection fee rates per capacity unit (equivalent single-family home) are provided in Table 7-5.

Table 7-5. Joint Outfall System Connection Fee Rates per Capacity Unit

District ^a	Fiscal Year 2006–07	Fiscal Year 2007–08	Fiscal Year 2008–09	Fiscal Year 2009–10	Fiscal Year 2010–11	Fiscal Year 2011–12	Fiscal Year 2012–13	Fiscal Year 2013–14
1	\$1,735	\$1,860	\$2,520	\$3,280	\$4,140	\$4,260	\$4,390	\$4,520
2	1,765	1,890	2,550	3,310	4,170	4,300	4,430	4,560
3	1,665	1,790	2,410	3,130	3,950	4,070	4,190	4,320
5	1,785	1,910	2,580	3,350	4,220	4,350	4,480	4,610
8	1,745	1,870	2,530	3,290	4,150	4,270	4,400	4,530
15	1,625	1,750	2,350	3,050	3,850	3,970	4,090	4,210
16	1,635	1,760	2,360	3,060	3,860	3,980	4,100	4,220
17	1,675	1,800	2,420	3,140	3,860	3,980	4,100	4,220
18	1,765	1,890	2,560	3,330	4,200	4,330	4,460	4,590
19	1,715	1,840	2,480	3,220	4,060	4,180	4,310	4,440
21	1,665	1,790	2,410	3,130	3,950	4,070	4,190	4,320
22	1,725	1,850	2,490	3,230	4,070	4,190	4,320	4,450

Table 7-5 (Continued)

District ^a	Fiscal Year 2006–07	Fiscal Year 2007–08	Fiscal Year 2008–09	Fiscal Year 2009–10	Fiscal Year 2010–11	Fiscal Year 2011–12	Fiscal Year 2012–13	Fiscal Year 2013–14
23	1,495	1,620	2,140	2,760	3,480	3,580	3,690	3,800
28 ^b	4,863	5,274	6,087	7,000	8,013	8,114	8,218	8,325
28 ^c	1,489	1,614	2,141	2,768	3,495	3,596	3,700	3,807
28 ^d	5,855	6,266	7,079	7,992	9,005	9,106	9,210	9,317
28 ^e	5,569	5,980	6,793	7,706	8,719	8,820	8,924	9,031
29	2,105	2,230	2,770	3,410	4,150	4,270	4,400	4,530
SBC	1,785	1,910	2,580	3,350	4,220	4,350	4,480	4,610

^a Although District No. 34 is a Joint Outfall District, it is currently inactive and, therefore, is not listed.

^b Rate applies to those users who connect in an area tributary to the La Cañada WRP.

^c Rate applies to those users who connect within a city of La Cañada Flintridge assessment district.

^d Rate applies to those users who directly connect to the La Cañada Outfall Trunk Sewer.

^e Rate applies to those users who directly connect to the Foothill Main Trunk Sewer.

7.5.3 Additional Sources of Revenue

In addition to the Service Charge and Connection Fee Programs, the Sanitation Districts rely on five revenue sources to support wastewater management services.

7.5.3.1 Ad Valorem Taxes

The Sanitation Districts receive a pro rata share of the 1-percent ad valorem property tax levy pursuant to Proposition 13. The pro rata share is based on the percentage of the total tax levy each district received prior to the implementation of Proposition 13 in fiscal year 1978–79. Accordingly, the pro rata share varies slightly from district to district. All ad valorem taxes are deposited into the respective district's operating fund and are used to help offset bonded indebtedness, operation expenses, and capital expenses. The average annual ad valorem taxes collected across the Joint Outfall Districts equates to approximately \$25 per single-family home.

7.5.3.2 Contracts

The Sanitation Districts generate revenue through disposal contracts to certain facilities located outside of the JOS boundaries. The contracts are structured to recover the total cost of services rendered to these facilities. In addition, revenue is generated through sales contracts for recycled water and power generated from the wastewater treatment process.

7.5.3.3 Industrial Waste Surcharge

In 1972, the Sanitation Districts instituted a surcharge program for industrial dischargers. It requires industrial dischargers to pay a fair share of operations and maintenance (O&M) and upgrade capital costs according to their usage of the sewerage system. Usage is measured in terms of three parameters: flow, COD, and SS. In addition, dischargers with excessive peak flows must pay a supplemental peak flow charge. The method for determining the surcharge rates is similar to that for determining the service charge rate.

7.5.3.4 Investment Income

Investment income refers to interest received during the fiscal year. This source of revenue is variable and depends on the cash balance maintained by each district as well as the prevailing interest rates. Sanitation Districts' funds are invested in various instruments in conformance with the Investment Policy that is adopted on an annual basis.

7.5.3.5 Annexation Fees

Annexation fees are paid by each property owner annexing territory into a district. The annexation fee program is in conformance with Cortese-Knox-Hertzberg Local Government Reorganization Act of 2000. The revenue received from annexation fees varies considerably and unpredictably. Since each annexation fee solely covers the cost of processing that annexation request, this revenue source is not relied on during budget preparation.

7.6 Project Financing

As discussed in Section 7.4.1, the portion of the estimated cost of the recommended projected attributable to upgrade is \$416,250,000 (2011 dollars). On a per sewage unit basis, this equates to \$214 per equivalent single-family home. If all of this had to be collected in a single year or even a few years, the impact would be unacceptable to the public. Therefore, it is imperative that a long-term financing solution be developed.

7.6.1 Available Financing Sources

There are generally two sources of long-term financing available for wastewater agencies: (1) SRF loans and (2) revenue bonds. In some respects, these two sources are very similar in that they both provide project funding with an extended repayment period at a fixed interest rate.

In the case of SRF loans, the repayment period is 20 years, beginning one year after the completion of construction at an interest rate equal to one-half of the most current state of California general obligation bond rate. Interest is capitalized during the construction period and calculated into the principal amount of the loan that must be repaid. Currently, there is an annual cap of \$50 million per agency on SRF loans.

In the case of revenue bonds, the repayment period is typically 30 years with repayment beginning as soon as the bonds are issued. Interest rates are dependent on market conditions on the date the bonds are issued and the financial strength of the Joint Outfall Districts. There are ways to structure revenue bonds so that the beginning of the repayment period can effectively be pushed back until construction is complete.

7.6.2 Financing Analysis

Because of the current cap on SRF loans, the funding for the recommended project is expected to be a combination of SRF loans and revenue bonds. However, by structuring the bonds to have repayment begin toward the end of construction, they would take on the appearance of SRF loans. Additionally, although bonds generally have higher interest rates than SRF loans, the longer repayment period makes it such that the annual payments are roughly equivalent under both funding options. Therefore, for the financing analysis, it is assumed that 20-year SRF loans at 3-percent interest would be used for funding the project attributable to the upgrade portions of the recommended project. Furthermore, it is assumed

that the expansion-related portions of the recommended project would be funded utilizing previously accumulated connection fees currently held in the Joint Outfall Districts' Capital Improvement Fund.

Because interest would be capitalized during construction, the total principal amount of the SRF loan must be projected into 2021 dollars. As discussed in Section 7.4, this equates to an estimated \$739 million. Using the upgrade/expansion allocations developed in Section 7.4.1, the total upgrade cost of the project in 2021 dollars would be \$559 million. At 3-percent interest for 20 years, this results in an annual repayment of \$37.6 million per year.

Based on the best available financing assumptions and escalation of construction costs, the recommended project would result in a service charge rate increase of approximately \$20 per year per sewage unit (or equivalent single-family home) in 2021 dollars (when construction would be completed). For comparison, the current JOS average annual service charge rate is \$146 per sewage unit.

7.6.3 Opportunities for Public Input

Even after a funding source has been identified, long-term financing cannot be undertaken until the Sanitation Districts actually adopt appropriate service charge rates to ensure that repayment can be made. Given the current economic climate and the public's concern over any rate increases, this is a process that would involve multiple opportunities for public input. At a minimum, the Sanitation Districts must comply with Proposition 218. For the Clearwater Program, this would entail mailing public notices to approximately 1.2 million property owners at least 45 days before the Joint Outfall Districts' Boards of Directors hold a public hearing. Each public notice, in addition to providing information about the public hearing, must include the actual charges to be imposed on a given parcel and the basis for those charges.

In practice, the Sanitation Districts typically go much further than what is required by law. The public notices explain what projects are being undertaken, what the cost is, and what the future rates would be. The notices also include a series of commonly asked questions and provide answers to those questions. Lastly, the notices reference the Sanitation Districts' internet site where, in addition to supplementary information, Spanish language translations are provided. Furthermore, the Sanitation Districts have a dedicated toll free telephone line for people to ask questions and obtain more information. Prior to the public hearing, the Sanitation Districts also conduct a series of information meetings, usually consisting of a brief presentation followed by a question and answer period. A video version of the information meetings is made available on the Sanitation Districts' internet site.

LIST OF APPENDICES

Appendix A	State Water Resources Control Board Requirements for Project Reports
Appendix B	Sanitation Districts That Provide Service to Local Jurisdictions
Appendix C	Design Criteria for the San Jose Creek Water Reclamation Plant
Appendix D	References
Appendix E	List of Preparers and Contributors
Appendix F	List of Abbreviations

Appendix A

STATE WATER RESOURCES CONTROL BOARD REQUIREMENTS FOR PROJECT REPORTS

State Revolving Fund Loan Program Compliance

The State Revolving Fund (SRF) loan program was created by the 1987 Amendments to the Federal Clean Water Act and replaces the previous federal grant program. The SRF loan program provides low interest loans for many public works projects, including construction of publicly owned treatment works.

The Sanitation Districts of Los Angeles County (Sanitation Districts) have prepared the Clearwater Program Master Facilities Plan (MFP) to identify a recommended plan that will meet the wastewater management needs of the Joint Outfall System (JOS) through the year 2050. The MFP identifies both program-level and project-level portions of the recommended plan. The program-level portion of the recommended plan includes: expansion of the conveyance system with approximately 32.5 miles of relief trunk sewers; expansion of the San Jose Creek WRP (SJCWRP) by 25 million gallons per day (MGD); process optimization at the Pomona WRP (POWRP), the SJCWRP, the Los Coyotes WRP (LCWRP), and the Long Beach WRP (LBWRP); a continuation of current practices for water reclamation plant (WRP) effluent management and biosolids management practices; and additional sludge stabilization facilities at the Joint Water Pollution Control Plant (JWPCP). The project-level portion of the recommended plan includes installation of a new effluent tunnel originating at the JWPCP and extending to the existing ocean outfall manifold structure at Royal Palms Beach near White Point. Rehabilitation of the existing ocean outfalls will be included in the project scope of work.

The SRF loan program is administered by the State Water Resources Control Board (SWRCB). The purpose of this appendix is to facilitate review of the project report requirements by the SWRCB. Applicable sections of the MFP are referenced, and in some cases, supplemental information is provided as necessary to address SRF requirements. The project, referred to as the recommended plan, is evaluated and defined in the MFP and analyzed the associated environmental impact report/environmental impact study (EIR/EIS), which was prepared by the environmental consulting firm ICF International in conformance with the California Environmental Quality Act and the National Environmental Policy Act, respectively. The Clearwater Program EIR/EIS is available under separate cover.

Project Report Requirements

The SRF Policy published by the SWRCB (as amended March 17, 2009) contains a list of items that a project report must contain, as appropriate. Applicable items addressed in the MFP are as follows:

- 1. A statement of Project needs and benefits, including a discussion of the water quality benefits of the Project and the public health or water quality problems to be corrected.*

The statement of the Clearwater Program purpose and needs, as well as the goal and objectives, are found in Section 1.4. Water quality and health benefits are also discussed in this section. A project needs assessment is included in Section 5.9.

2. *Proposed Project service area and composition information:*

- a. *Median household income (MHI) and population for the proposed Project service area using census data or the most recent income survey if the census data do not accurately reflect the community's MHI.*

The MHI and population, derived from the Department of Finance, are contained in Sections 2.2.3 and 2.2.1, respectively. In 2000, the MHI was \$47,834 and the population was 4,720,505 within the JOS service area.

- b. *Total number of active wastewater service connections that are currently and directly served by the wastewater collection system. This includes a breakdown by each category for all domestic or residential, industrial, commercial, or other connections. A map for the existing wastewater service area for the proposed Project must be provided.*

As of fiscal year 2010-2011, a total of 1,068,384 parcels are served by the JOS. Of this number: 1,005,667 are domestic or residential; 19,894 are industrial; 40,609 are commercial; and 2,214 are other (such as schools, government buildings, etc.). A map of the existing wastewater service area for the recommended plan is shown in Chapter 1 (Figure 1-2).

- c. *The average current monthly wastewater charges by category. If the wastewater system uses a "tiered" rate, the charge should reflect what a typical user pays in each category and the basis of the charges. The rate should reflect direct wastewater charges plus any other fees or charges that support the wastewater service such as parcel fees, standby charges, wastewater taxes, and surcharges.*

The historic, current, and adopted wastewater service charge rates within the JOS are contained in Section 7.5.1 and shown in Table 7-4. Rates within the JOS are not tiered. Approximately \$25 per year of local property taxes per parcel supports wastewater service. An average of \$41 per year is charged for local sewer maintenance by the district or city responsible for such maintenance.

3. *A cost effectiveness and climate change evaluation of alternatives over the useful life of the Project. The evaluations presented must include an evaluation of the alternative of upgrading operation and maintenance of the existing facility to improve effluent quality, and a regional treatment solution.*

Alternatives are evaluated for cost effectiveness in Chapter 6 in both the Level 2 and Level 3 screening (Sections 6.2.6.4 and 6.3.4.2, respectively). The alternatives are evaluated for climate change (greenhouse gasses) in Section 6.2.1.4, where they are considered as part of regulatory compliance in Level 2 screening, and in Chapter 9 of the associated Clearwater Program EIR/EIS. Upgrading operation and maintenance of existing facilities has been evaluated on a regional basis spanning the JOS.

4. *An evaluation of alternative methods for reuse or ultimate disposal of treated wastewater and sludge material resulting from the treatment process.*

Section 5.4 discusses WRP effluent management while Section 5.6 discusses effluent management at the JWPCP. Section 5.8 discusses the biosolids history, biosolids strategy, recent management practices, landfill co-disposal, and future solids management. Alternative methods are evaluated in Section 6.2 for program components and Section 6.3 for project elements.

For wastewater treatment Projects producing sludge material, the following information needs to be identified and compared:

- a. *All landfills within a 100-mile radius that accept sewage sludge;*

All landfills within at least a 100-mile radius that accept sewage sludge are identified in Chapter 5 and shown in Table 5-9.

- b. *Any composting facilities within a 100-mile radius accepting sewage sludge;*

All composting facilities within at least a 100-mile radius that accept sewage sludge are identified in Chapter 5 and shown in Table 5-9.

- c. *The potential for dedicated land disposal;*

Future solids management is discussed in Section 5.8.5. All of the solids generated in the JOS are conveyed to and treated at the JWPCP. Biosolids management follows a diversified management program that actively seeks out alternative biosolids disposal methods as discussed in Section 5.8.2.

- d. *Conversion of sludge to biosolids for distribution as soil amendment or as another agricultural product; and*

The sludge material is anaerobically digested at the JWPCP, becoming biosolids, and is concentrated in centrifuges. Recent solids handling practices in the JOS are discussed in Section 5.8.3.

- e. *Ultimate disposal methods approved by the Regional Water Boards.*

Disposal methods for solids generated in the JOS are discussed in Sections 5.8.3 through 5.8.5. All in-state facilities have been approved by the Regional Water Board with local oversight responsibility. All out of state facilities have been approved by the appropriate regulatory agencies with oversight responsibility.

5. *An evaluation of the non-existence or possible existence of excessive infiltration/inflow (I/I) in the existing sewer system. If the average daily flow during periods of sustained high groundwater is less than 120 gallons per capita per day (gpcd), a Sewer System Evaluation Survey (SSES) is not required. If it is above 120 gpcd, the applicant must perform a SSES to determine whether it is cost-effective to treat or correct the I/I. If a SSES is not submitted, funding will be based on a maximum flow rate of 120 gpcd. If the peak flow during a storm event (highest three-hour average) exceeds 275 gpcd, a SSES must be completed or funding will be based on a maximum peak flow rate of 275 gpcd. Cost-effective corrections under these criteria are eligible for funding.*

An evaluation of I/I is provided in Section 4.8.3.3.

6. *Information on total capital costs, annual operation and maintenance costs.*

Total capital cost, total annual cost, and the estimated cost to users for implementing the recommended plan are provided in Sections 7.2, 7.4, and 7.6.

7. *A discussion of the existing population, flows, loadings, and projections of the same, used to estimate the capacity needs for the funded facilities.*

Section 4.8 discusses wastewater flow projections. Existing and projected population, flows, and loadings are discussed in Sections 4.8.1.2, 4.8.2, and 4.8.1.1, respectively.

8. *A discussion of the anticipated eligible capacity for the Project, and how that capacity was derived.*

The anticipated eligible capacity and its derivation are identified in Section 4.8.

9. *A summary of public participation.*

Sections 1.4.5 and 6.1.4, respectively, summarize the public participation efforts for the Clearwater Program. A greater level of detail is provided in the associated Clearwater Program Agency and Public Scoping Report, which is available under separate cover in Appendix 1-B of the EIR/EIS.

10. *The following must be submitted for the selected alternative:*

a. *A detailed description of the selected alternative and the complete waste treatment system of which it is a part;*

Section 7.2 contains a summary of the selected alternative. Chapter 5 provides an overview of the complete JOS waste treatment system.

b. *A summary of relevant design criteria (i.e., design flow, peak flows, daily Biochemical Oxygen Demand (BOD) or Chemical Oxygen Demand (COD) loadings, daily suspended solids loadings, overflow rates, detention times, sludge production, etc.);*

The recommended plan includes the expansion of the SJCWRP. A summary of the design criteria for this plant is contained in Appendix C and shown in Table C-1.

c. *The estimated construction and annual operation and maintenance costs and a description of the anticipated manner in which all the costs will be financed;*

Costs associated with the recommended plan are provided in Sections 7.2 and 7.4, the Sanitation Districts' revenue program is described in Section 7.5, and financing is presented in Section 7.6. Operation and maintenance costs are anticipated to remain the same for the proposed modified ocean discharge system.

d. *A summary of the cost impacts on wastewater system users. Provide the average projected monthly wastewater charges that will be passed on to wastewater users by category and the basis of the charges during the useful life of the proposed Project. Include any ineligible project costs as well as non-Project-related wastewater system costs that will be imposed on*

the residential users during the next five years. Also include any income generated by the project, such as income generated by the sale of recycled water;

Total capital cost, total annual cost, and the estimated cost to users for implementing the recommended plan are provided in Sections 7.2, 7.4, and 7.6. Past, current, and future adopted Service Charge and Connection Fee rates are provided in Section 7.5. No additional operation and maintenance costs would be incurred. The proposed modified ocean discharge system would not result in the generation of income.

- e. A summary of the significant environmental impacts of the selected Project and any proposed mitigation measures;*

The Clearwater Program Executive Summary, which is available under separate cover, provides a summary of all significant environmental impacts of the recommended plan and the proposed mitigation measures.

- f. A statement that identifies and discusses the source(s) and the amount of unallocated potable water currently available in the Project service area. If the amount of potable water is less than what is needed to serve the projected population for the proposed Project, a plan identifying how that deficiency will be mitigated shall be presented;*

A comprehensive discussion of existing and future water supply and demand is provided in Sections 4.1, 4.2, 4.3, 4.4, 4.5, and 4.6. As described in Section 4.8, population projections provided by the Southern California Association of Governments were used as the basis for projecting future flows within the JOS service area and determine the wastewater management facilities necessary to accommodate the projected flows. Therefore, the Clearwater Program is growth accommodating, not growth inducing.

- g. A discussion of facilities that were previously funded by federal/state grants, loans, or other financing, if such facilities are to be repaired or replaced;*

The Clearwater Program would not involve the replacement of existing facilities. The ocean outfalls being proposed for rehabilitation were not funded by federal/state grants, loans, or other financing.

- h. A discussion, if applicable, where minority populations are included in the facilities planning area, showing that such areas will be served or excluded from service only for reasons of cost-effectiveness. Applicants must comply with the Civil Rights Act of 1964.*

The Clearwater Program is in compliance with the Civil Rights Act of 1964 in that wastewater management services are provided in a cost-effective manner to all residents within its service area, without regard to race, color, religion, sex, national origin, age, disability, ancestry, marital status, cancer-related medical condition, or status as a disabled veteran. Refer to of the MFP, Section 2.2, for a description of the social-economic characteristics of the region.

- i. A description of operation and maintenance requirements;*

The operation and maintenance requirements for the proposed modified ocean discharge system would be the same as those for the existing tunnel and ocean outfalls. Tunnel/outfall

operation consists of opening and closing the valves that control the routing of the effluent through the specific outfalls. Maintenance requirements include general valve maintenance for the above noted valves and annual underwater inspection of the outfall, followed by maintenance (typically re-ballasting) as required.

- j. A demonstration that the selected alternative is consistent with any applicable approved water quality management plan;*

The recommended plan would provide for continued compliance with all applicable effluent and receiving water standards in the 1994 Water Quality Control Plan for the Los Angeles Region. Refer to Section 3.2.2 for more details on state water quality management regulations.

- k. A summary of public participation; and*

Sections 1.4.5 and 6.1.4, respectively, summarize the public participation program for the Clearwater project. A greater level of detail is provided in the Clearwater Program Agency and Public Scoping Report, which is available under separate cover in Appendix 1-B of the EIR/EIS.

- l. For existing facilities, the applicant must submit a copy of the current adopted WDRs issued by the Regional Water Board. If there are no existing facilities, the applicant must submit a copy of the tentative WDRs, which must become final before disbursement of costs for construction. Division staff will track the status of the WDRs and may require additional relevant information and updates from the applicant.*

There are current adopted WDRs for the JWPCP and WRPs. The WDRs issued by the Los Angeles Regional Water Board for the can be found at the following links:

- JWPCP: http://63.199.216.6/larwqcb_new/permits/docs/1758_R4-2011-0151_WDR_PKG.pdf
 - Pomona WRP: http://63.199.216.6/larwqcb_new/permits/docs/0755_R4-2009-0076_WDR.pdf
 - Whittier Narrows WRP: http://63.199.216.6/larwqcb_new/permits/docs/2848_R4-2009-0077_WDR_PKG.pdf
 - San Jose Creek WRP: http://63.199.216.6/larwqcb_new/permits/docs/5542_R4-2009-0078_WDR.pdf
 - Long Beach WRP: http://63.199.216.6/larwqcb_new/permits/docs/5662_R4-2007-0047_WDR_PKG.pdf
 - Los Coyotes WRP: http://63.199.216.6/larwqcb_new/permits/docs/5059_R4-2007-0048_WDR_PKG.pdf
 - La Cañada WRP: There are no on-line documents for the La Cañada WRP.
- m. Applicants requesting Extended Term Financing must include the following in the Project Report: 1) an assessment of the useful life of the selected alternative; and 2) an affordability analysis, which demonstrates the financing term necessary to make the selected alternative affordable for the community.*

Extended Term Financing is not being requested for this project.

11. A description of how the applicant's Project addresses each of the state planning priorities defined in Section 65041.1 of the Government Code and sustainable water resource management priorities. These are intended to promote equity, strengthen the economy, protect the environment, and promote public health and safety in the state, including in urban, suburban, and rural communities. The state planning priorities and sustainable water resources management priorities as of the date of adoption of this Policy are as follows:

- a. To promote infill development and equity by rehabilitating, maintaining, and improving existing infrastructure that supports infill development and appropriate reuse and redevelopment of previously developed, underutilized land that is presently served by transit, streets, water, sewer, and other essential services, particularly in underserved areas, and to preserving cultural and historic resources;*

Sections 7.2 and 7.3 describe the recommended plan, which improves existing infrastructure, therefore supporting infill development and appropriate reuse and redevelopment of underutilized land.

- b. To protect environmental and agricultural resources by protecting, preserving, and enhancing the state's most valuable natural resources, including working landscapes such as farm, range, and forest lands, natural lands such as wetlands, watersheds, wildlife habitats, and other wildlands, recreation lands such as parks, trails, greenbelts, and other open space, and landscapes with locally unique features and areas identified by the state as deserving special protection;*

Section 4.10 discusses the use of recycled water to benefit the local environment. As described in Chapters 4, 6, 11, 12, 13, and 17 of the Clearwater Program EIR/EIS, which is available under separate cover, the recommend plan would result in less than significant impacts to natural resources such as working landscapes, recreation lands, and landscapes afforded special state protection.

- c. To encourage efficient development patterns by ensuring that any infrastructure associated with development that is not infill supports new development that uses land efficiently, is built adjacent to existing developed areas to the extent consistent with the priorities specified pursuant to subdivision (b), in an area appropriately planned for growth, services, and minimizes ongoing costs to taxpayers.*

New facilities associated with the recommended plan would be located primarily at existing treatment plant sites or within existing developed areas; therefore, infill development patterns would be more likely to follow this project.

- d. To encourage sustainable water resources management by ensuring that sustainable water resources measures, such as recycling wastewater, conserving water, conserving energy, and applying Low Impact Development Best Management Practices to the maximum extent practicable. Agencies that are legislatively prohibited from engaging in these activities are exempt from this requirement. Exempt agencies shall provide a statement in their Project Report citing the legislation and what activities are prohibited.*

Section 3.5 discusses regulations associated with recycled water reuse. All wastewater entering the JOS WRPs is treated to a level suitable for reuse. This recycled water is made available to local water wholesale or retail agencies, which in turn supply recycled water to

their clients. Per the California Public Utilities Code Chapter 8.5, Service Duplication, the Sanitation Districts are prohibited from selling recycled water directly to a user served by a private water company.

State Revolving Fund Water Conservation Requirement

The Sanitation Districts are not water purveyors. Therefore, to comply with SRF requirements, the Sanitation Districts must (1) certify that 75 percent of the water connections in the service area are covered by adopted water conservation programs approved by the Division or (2) demonstrate that the water purveyors have signed the Memorandum of Understanding covering at least 75 percent of the water connections with the sewer service area.

Table A-1 lists the member agencies of the Metropolitan Water District of Southern California (MWD) that serve the JOS service area and their total water supply for fiscal year 2009-10 in acre-feet (AF). Of an estimated 954,644 AF of total water supply utilized in the JOS service area in fiscal year 2009-10, at least 950,032 AF came from member agencies that are signatory to a memorandum of understanding with MWD. Therefore, 99.5 percent of the water supplied by MWD was through signatory agencies. Since these agencies provide more than 75 percent of the total water supply within the JOS, the Sanitation Districts are in compliance with the SRF water conservation requirement.

Table A-1. Total Water Supply for Signatory Agencies (Fiscal Year 2009-2010)

Member Agency	Total Water Supply (AF)	Water Supply of Signatory Agencies (AF)
Central Basin MWD	301,381	301,381
City of Compton	8,270	8,270
Foothill MWD	20,125	20,125
City of Long Beach	63,742	63,742
City of Pasadena	33,755	33,755
City of San Marino	4,612	NS
Three Valleys MWD	117,028	117,028
City of Torrance	23,613	23,613
Upper San Gabriel MWD	205,387	205,387
West Basin MWD	176,731	176,731
Total:	954,644	950,032

AF = acre feet

NS = not a signatory agency to the MOU

Source: MWD Annual Report for Fiscal Year 2009-10 (<http://www.mwdh2o.com/mwdh2o/pages/about/AR/AR10.html>)

Appendix B

SANITATION DISTRICTS THAT PROVIDE SERVICE TO LOCAL JURISDICTIONS

Table B-1. Sanitation Districts That Provide Service to Local Jurisdictions

Jurisdiction	District
Alhambra	2-16
Arcadia	15-22
Artesia	2-18-19
Azusa	22
Baldwin Park	15-22
Bell	1-2
Bellflower	2-3-18
Bell Gardens	2
Beverly Hills	4
Bradbury	15-22
Carson	8
Cerritos	2-3-18-19
Claremont	21
Commerce	2
Compton	1-2-8
Covina	22
Cudahy	1
Culver City	5
Diamond Bar	21
Downey	2-18
Duarte	15-22
El Monte	15
El Segundo	SBC-5
Gardena	5
Glendora	22
Hawaiian Gardens	19
Hawthorne	5
Hermosa Beach	SBC
Huntington Park	1
Industry	15-18-21
Inglewood	5
Irwindale	15-22
La Cañada Flintridge	28-34
La Habra Heights	18
Lakewood	3-19
La Mirada	18

Table B-1 (Continued)

Jurisdiction	District
Lancaster	14
La Puente	15-21
La Verne	21-22
Lawndale	5
Lomita	5
Long Beach	1-2-3-8-19
Los Angeles	1-2-3-4-5-8-9-16
Lynwood	1
Manhattan Beach	SBC-5
Maywood	1
Monrovia	15-22
Montebello	2-15
Monterey Park	2-15
Norwalk	2-18
Palmdale	14-20
Palos Verdes Estates	SBC-5
Paramount	1-2
Pasadena	15-16-17
Pico Rivera	2-18
Pomona	21
Rancho Palos Verdes	SBC-5
Redondo Beach	SBC-5
Rolling Hills	5
Rolling Hills Estates	SBC-5
Rosemead	15
San Dimas	21-22
San Gabriel	2-15
San Marino	15-16
Santa Clarita	SCV (32)
Santa Fe Springs	18
Sierra Madre	15
Signal Hill	3-29
South El Monte	15
South Gate	1-2
South Pasadena	16
Temple City	15
Torrance	SBC-5
Vernon	1-2-23
Walnut	21-22
West Covina	15-21-22
West Hollywood	4
Whittier	2-15-18
Los Angeles County	1-2-3-5-8-9-14-15-16-17-18-19-20-21-22-SCV
Unincorporated Area Only	27

Source: Sanitation Districts of Los Angeles County 2011

Appendix C

DESIGN CRITERIA FOR THE SAN JOSE CREEK WATER RECLAMATION PLANT

Table C-1. Design Criteria for the San Jose Creek WRP

Design Element	Units	SJCWRP-East (Existing)	SJCWRP-West (Existing)	SJCWRP-West (Ultimate)
Plant Flows				
Average	MGD	62.5	37.5	62.5
Peak Sanitary	MGD	90	60	100
Peak Storm	MGD	125	75	125
Equalized Waste Filter Backwash	MGD	1.6	-	-
Primary Sedimentation Tanks				
Number	-	8	5	8
Dimensions (LxWxD)	feet	300x20x12	300x20x12	300x20x12
Avg. Overflow Rate	gpd/ft ²	1,300	1,300	1,300
Avg. Detention Time	hours	1.65	1.65	1.65
SS Removal (Avg)	%	65	62	62
BOD ₅ Removal (Avg)	%	35	36	36
Aeration Tanks				
Process Configuration	-	SFA	SFA	SFA
Number	-	20	12	20
Dimensions (LxWxD)	feet	225x30x15	225x30x15	225x30x15
Fraction Anoxic	%	25	25	25
Fraction Aerobic	%	75	75	75
Equipment Type	-	Fine Bubble	Fine Bubble	Fine Bubble
Make	-	Sanitaire	Sanitaire	Sanitaire
HRT Total	hours	1.86	1.86	1.86
Process Air Compressors				
Number	-	5	3	3
Type	-	Centrifugal	Centrifugal	Centrifugal
Capacity (Per Unit)	cfm	3@44,000 2@20,000	44,000	44,000
Final Sedimentation Tanks				
Number, Total	-	30	18	30
Number Assigned to BWR	-	-	-	-
Dimensions (LxWxD)	feet	150x20x10	150x20x10	150x20x10
Avg Overflow Rate	gpd/ft ²	694	694	694
Avg Detention Time	hours	1.94	1.94	1.94

Table C-1 (continued)

Design Element	Units	SJCWRP-East (Existing)	SJCWRP-West (Existing)	SJCWRP-West (Ultimate)
Filters				
Number	-	20	14	24
Type	-	Gravity - Dual	Gravity - Mono	Gravity - Mono
Dimensions (LxWxD media)	feet	37x16x7.6	37x16x7.2	37x16x7.2
Avg SLR (All in Service)	gpd/ft ²	3.63	3.11	3.03
Filter Effluent Pumps				
Number	-	5	3	3
Type	-	Vertical Mixed Flow	Vertical Mixed Flow	Vertical Mixed Flow
Capacity Per Pump	gpm	2@22,800 1@22,000 1@12,200 1@13,800	23,000	23,000
Filter Backwash Pumps				
Number	-	2	2	2
Type	-	Vertical Mixed Flow	Vertical Mixed Flow	Vertical Mixed flow
Capacity Per Pump	gpm	6,500	13,500	13,500
Filter Waste Backwash Recovery Tank				
Number	-	1	1	1
Volume (Effective)	gallons	136,925	135,000	135,000
Chlorine Contact Tanks				
Number	-	4 (Series)	4	6
Dimensions (LxWxD)	feet	386x13x16	300x27x15	300x27x15
Notes:				
Avg = average				
MGD = million gallons per day				
gpd = gallons per day				
gpm = gallons per minute				
ft ² = square feet				
cfm = cubic feet per minute				
SFA = step-feed anoxic				
SS = suspended solids				
COD = chemical oxygen demand				
BOD ₅ = biochemical (or biological) oxygen demand				
HRT = hydraulic retention time				
BWR = backwash recovery				
SLR = surface loading rate				

Appendix D REFERENCES

- Bass, Ronald E., Albert I. Herson, and Kenneth M. Bogdan. 1999. *California Environmental Quality Act Deskbook*. Point Arena, California: Solano Press Books.
- California Air Resources Board. 2004. *The California Diesel Fuel Regulations. Title 13, California Code of Regulations, Section 2281-2285, Title 17, California Code of Regulations, Section 93114*.
- California Air Resources Board. 2010. *Amendments to the Regulations Applicable to Portable Diesel Engines and Diesel Engines Used in Off-Road and On-Road Vehicles*.
- Larry Walker Associates. 2007. *Summary of Recycled Water Plans Within CSDLAC's Service Area*. February.
- Los Angeles Almanac. 2011. *Monthly Climate Summaries at Selected Los Angeles County Locations Averages Through 2006*. Available: <<http://www.laalmanac.com/weather/we02.htm>>. Accessed: September 12, 2011.
- Metropolitan Water District of Southern California. 2007. *Groundwater Assessment Study*. September. Available: <<http://www.mwdh2o.com/mwdh2o/pages/yourwater/supply/groundwater/gwas.html>>. Accessed: September 12, 2011.
- Metropolitan Water District of Southern California. 2010. *Integrated Water Resources Plan 2010 Update*. Report Number 1373. October.
- Metropolitan Water District of Southern California, Los Angeles County Sanitation Districts, Orange County Sanitation Districts, Orange County Water Districts, City of Los Angeles Bureau of Engineering, City of Los Angeles Department of Water and Power, United States Environmental Protection Agency Region IX, California State Water Resources Control Board, Los Angeles Regional Water Quality Control Board, Santa Ana Regional Water Quality Control Board, Southern California Association of Governments. 1982. *Orange and Los Angeles Counties Water Reuse Study Facilities Plan*. April.
- National Oceanic and Atmospheric Administration (NOAA). 1973. *Precipitation Frequency Atlas of the Western United States, Volume III* by J.F. Miller, R.H. Frederick, and R.J. Tracey.
- Parkhurst, J.D., Sanitation Districts of Los Angeles County. 1963. *A Plan for Water Reuse*. July.
- Parsons, in association with Jacobs Associates and Black & Veatch. 2011. *Professional Design Services for the Preliminary Engineering of the Joint Water Pollution Control Plant Tunnel and Ocean Outfall Feasibility Report*. November.
- Regional Water Quality Control Board, Region 4. 1995. *Water Quality Control Plan Los Angeles Region*. February.

- Sanitation Districts of Los Angeles County (Sanitation Districts). 1965. *Recommendation of "Plan A" to the Boards of Directors*, A Transmittal by John D. Parkhurst, Chief Engineer and General Manager. October.
- Sanitation Districts. 1977. *Joint Outfall System Facilities Plan and EIR/EIS*. July.
- Sanitation Districts. 1995a. *Joint Outfall System 2010 Master Facilities Plan*. June.
- Sanitation Districts. 1995b. *Plan for Beneficial Reuse of Reclaimed Water*. December.
- Sanitation Districts. 2001. *Joint Outfall System Nitrification/Denitrification Facilities Plan*. December.
- Sanitation Districts. 2010. *Twentieth Annual Status Report on Recycled Water Use Fiscal Year 2008-2009*. July.
- Sanitation Districts. 2011. *Twenty-first Annual Status Report on Recycled Water Use Fiscal Year 2009-2010*. July.
- Schwarm, W., California Department of Finance. 2010. *Los Angeles County Code 037 Census*. Available: <<http://www.dof.ca.gov/HTML/DEMOGRAP/Druhpar.asp>>. Accessed: September 12, 2011.
- South Coast Air Quality Management District (SAQMD). 2007. *Final 2007 Air Quality Management Plan*. June. Diamond Bar, CA.
- Southern California Association of Governments (SCAG). 2008. *2008 Regional Transportation Plan (2008 RTP): Making the Connections*. May. Available: <<http://www.scag.ca.gov/rtp2008/>>. Accessed: November 16, 2011.
- State of California, Department of Finance, Demographic Research Unit. 2010. *Tract-to-Tract Comparability File*. Available: <http://www.dof.ca.gov/research/demographic/state_census_data_center/products-services/view.php#TractComp>. Accessed: September 12, 2011.
- United States Bureau of Reclamation, California Department of Water Resources, Central Basin and West Basin Municipal Water Districts, City of Los Angeles, City of San Diego, Metropolitan Water District of Southern California, San Diego County Water Authority, Santa Ana Watershed Project Authority, South Orange County Reclamation Authority. 2002. *Southern California Comprehensive Water Reclamation and Reuse Study Phase II Final Report*. July.
- United States Census Bureau. 2011. Census Bureau Home Page. Available: <<http://www.census.gov/>>. Accessed: November 10, 2011.
- United States Environmental Protection Agency. 2006. *Direct final Rule and Notice of Proposed Rulemaking for Amendments to the Non-Road and Highway Diesel Fuel Regulations*. Available: <<http://www.epa.gov/otaq/regs/fuels/diesel/diesel.htm>>. Accessed: November 10, 2011.
- United States Environmental Protection Agency. 2010a. *General Conformity Rule*. April.
- United States Environmental Protection Agency. 2010b. *Extension of Deadline for Promulgating Designations for 2008 Ozone NAAQS*. January.

Appendix E

LIST OF PREPARERS AND CONTRIBUTORS

Sanitation Districts of Los Angeles County

Management

Chief Engineer and General Manager	Grace R. Chan, PE
Chief Engineer and General Manager	Stephen R. Maguin, PE
Assistant Chief Engineer and Assistant General Manager	Robert C. Ferrante, PE
Department Head, Facilities Planning	Thomas J. LeBrun, PE
Assistant Department Head, Facilities Planning	Raymond L. Tremblay, PE
Assistant Department Head, Facilities Planning	Charles E. Boehmke, PE

Project Team

Project Manager, Supervising Engineer	Steven W. Highter, PE
Senior Engineer	Joseph Houghton, PE
Senior Engineer	Paul Mikulas, PE
Senior Engineer	David Haug, PE
Senior Engineer	Angela Chang, PE
Senior Engineer	Mary Jacobs, PE
Senior Engineer	Glenn Acosta, PE
Civil Engineer	Mark Giljum, PE
Civil Engineer	Wendy Wert, PE
Environmental Planner	Peter Wilt
Environmental Planner	Rene Rubalcava

Environmental Planner

Dave Guttman

Environmental Planner

Eric Kenney

Prime Consultant Firms

CH2M Hill

Project Manager

Judi Miller, PE

Flow Projections and Conveyance Task Lead

Jeff Friesen, PE

Quality Assurance/Quality Control

Fred Soroushian, PE

MWH

Project Manager

Don Bassett, PE

Wastewater Treatment Task Lead

Roger Stephenson, PE

Quality Assurance/Quality Control

Geoff Carthew, PE

Other Consultant and Subconsultant Firms

Preliminary Engineering

Parsons Water Infrastructure, Inc.

Jacobs Associates

Fugro West, Inc.

Advanced Earth Sciences, Inc.

Brierley Associates, Inc.

Environmental Analysis

ICF

Regulatory Analysis

Oakley Water Strategies, Inc.

Public Outreach

Public Affairs International

Cerrell Associates

Appendix F

LIST OF ABBREVIATIONS

°F	degrees Fahrenheit
µg/L	micrograms per liter
1977 Plan	1977 JOS Facilities Plan
2010 Plan	Joint Outfall System 2010 Master Facilities Plan
ACS	American Community Survey
ADWF	average dry weather flow
AF	acre-feet
AFY	acre-feet per year
AQMP	air quality management plan
ATCM	Airborne Toxic Control Measure
AWTF	Advanced Water Treatment Facility
AWWA	American Water Works Association
BACT	best available control technology
Basin Plan	Water Quality Control Plan, Los Angeles Region
BM	Biosolids Management
BMP	best management practice
BOD	biochemical (or biological) oxygen demand
CAA	Clean Air Act
CAAQS	California Ambient Air Quality Standards
Cal/OSHA	California Occupational Safety and Health Administration
CARB	California Air Resources Board
CBMWD	Central Basin Municipal Water District
CCC	California Coastal Commission
CCR	California Code of Regulations
CCT	chlorine contact tank
CDFG	California Department of Fish and Game
CDPH	California Department of Public Health
CDWS	California drinking water standards

CEC	Constituents of Emerging Concern
CEQ	Council on Environmental Quality
CEQA	California Environmental Quality Act
CERCLA	Comprehensive Environmental Response, Compensation, and Liability Act
CESA	California Endangered Species Act
cfm	cubic feet per minute
CFR	Code of Federal Regulations
cfs	cubic feet per second
CFU	Coliform Forming Units
CI	cast iron
CII	commercial, industrial, and institutional
CIP	capital improvement plan
CMOM	capacity, management, operations, and maintenance
CO	carbon monoxide
CO ₂	carbon dioxide
CO ₂ e	carbon dioxide equivalents
COD	chemical oxygen demand
Corps	U.S. Army Corps of Engineers
County DPH	Los Angeles County Department of Public Health
CPRC	California Public Resources Code
CRS	combined raw sludge
CSDLAC	County Sanitation Districts of Los Angeles County
CSLC	California State Lands Commission
CT	(wastewater) conveyance and treatment
CT	contact time
CTR	California Toxics Rule
CUP	conditional use permit
CWA	Clean Water Act
CWC	California Water Code
CZMA	Coastal Zone Management Act
DAF	dissolved air flotation
DDD	dichlorodiphenyldichloroethane
DDE	dichlorodiphenyldichloroethylene

DDT	dichlorodiphenyltrichloroethane
Delta	Sacramento-San Joaquin Delta
DHS	Department of Health Services
DOF	Department of Finance
DPM	diesel particulate matter
DRP	Department of Regional Planning
dtpd	dry tons per day
DWR	Department of Water Resources
DWUR	Dry weather urban runoff
EIR	environmental impact report
EIR/EIS	environmental impact report/environmental impact statement
EIS	environmental impact statement
EPA	U.S. Environmental Protection Agency
EPB	earth-pressure balance
FESA	federal Endangered Species Act
GBT	gravity belt thickener
General Permit	General Waste Discharge Requirements for Landscape Irrigation Uses of Municipal Recycled Water
GHG	greenhouse gas
GIS	geographic information system
gpcd	gallons per capita per day
gpm	gallons per minute
GRIP	Groundwater Reliability Improvement Program
GRP	Gross Regional Product
GRRP	groundwater reuse recharge project
GVWR	gross weight rating greater
HSWA	Hazardous and Solid Waste Amendments of 1984
HWCA	Hazardous Waste Control Act
I-	Interstate
I/I	infiltration and inflow
ICM	Inflow Coefficient Method
in/hr	inches per hour
IRP	Integrated Resource Planning
ISWP	Inland Surface Waters Plan

IW	industrial waste
JAA	Joint Administration Agreement
JE	JWPCP Effluent Management
JO	Joint Outfall
JOA	Joint Outfall Agreement
JOS	Joint Outfall System
JWPCP	Joint Water Pollution Control Plant
Kellogg	H.C. Kellogg
LA/OMA	Los Angeles/Orange County Metropolitan Area
LACAWRP	La Cañada Water Reclamation Plant
LACDPW	Los Angeles County Department of Public Works
LARWQCB	Los Angeles Regional Water Quality Control Board
LAXT	Los Angeles Export Terminal
lbs/d	pounds per day
LBWD	Long Beach Water Department
LBWRP	Long Beach Water Reclamation Plant
LCFS	low carbon fuel standard
LCWRP	Los Coyotes Water Reclamation Plant
LFG	landfill gas
M&I	municipal and industrial
MBR/RO	membrane bioreactor/reverse osmosis
MBRs	membrane bioreactors
MCL	maximum contaminant level
MF/RO	microfiltration and reverse osmosis
MFP	(Clearwater Program) Master Facilities Plan
MG	million gallons
mg/L	milligrams per liter
MGD	million gallons per day
MGY	million gallons per year
mL	milliliters
MLE	Modified Ludzack-Ettinger
MLSS	mixed liquor suspended solids
MPAs	Marine Protected Areas
MPN	most probable number

MW	megawatts
MWD	Metropolitan Water District of Southern California
MWh	megawatt hour
NAAQS	National Ambient Air Quality Standards
NACWA	National Association of Clean Water Agencies
NAHC	Native American Heritage Commission
NDMA	N-nitrosodimethylamine
NDN	nitrification-denitrification
NDN Plan	Nitrification/Denitrification Facilities Plan
NEPA	National Environmental Policy Act
NHPA	National Historic Preservation Act
NMFS	National Marine Fisheries Service
NO _x	nitrogen oxide
NPDES	National Pollutant Discharge Elimination System
NTR	National Toxics Rule
NTUs	nephelometric turbidity units
O&M	operations and maintenance
OES	Office of Emergency Services
OLAC	Orange and Los Angeles County
OPR	Office of Planning and Research
PCA	Porter-Cologne Water Quality Control Act of 1969
PERP	Statewide Portable Equipment Registration Program
PM	particulate matter
PM ₁₀	respirable particulate matter
PM _{2.5}	fine particulate matter
POTWs	publicly owned treatment works
POWRP	Pomona Water Reclamation Plant
ppcd	pounds per capita per day
ppd	pounds per day
PV Shelf	Palos Verdes Shelf
RCP	reinforced concrete pipe
RCRA	Resource Conservation and Recovery Act
RDI/I	rainfall dependent infiltration and inflow
RO	reverse osmosis

RPS	raw primary sludge
RTP	Regional Transportation Plan
RWC	recycled water contribution
RWQCBs	Regional Water Quality Control Boards
SAA	Streambed Alteration Agreement
Sanitation Districts	Sanitation Districts of Los Angeles County
SB	Senate Bill
SCAB	South Coast Air Basin
SCAG	Southern California Association of Governments
SCAQMD	South Coast Air Quality Air District
SDWA	Safe Drinking Water Act
SDWSRF	Safe Drinking Water State Revolving Fund
SEA	significant ecological area
SEATAC	Significant Ecological Areas Technical Advisory Committee
sf	square feet
SFA	Step-Feed Anoxic
SFR	single-family residence
SHPO	State Historic Preservation Officer
SIP	State Implementation Plan
SJCWRP	San Jose Creek Water Reclamation Plant
SOI	sphere of influence
SP	Solids Processing
SP Shelf	San Pedro Shelf
SR-	State Route
SRF	State Revolving Fund
SS	suspended solids
SSECAP	Sewer System Evaluation and Capacity Assurance Plan
SSES	Sewer System Evaluation Survey
SSMP	sewer system management plan
SSO	Sanitary Sewer Overflow
SWP	State Water Project
SWPPP	storm water pollution prevention plan
SWRCB	State Water Resources Control Board
TBM	tunnel boring machine

TDS	total dissolved solids
THM	trihalomethane
TICH	Total Identifiable Chlorinated Hydrocarbons
TMDL	Total Maximum Daily Load
TOC	total organic carbon
TraPac	Trans Pacific Container Service Corporation
TSDF	treatment, storage, and disposal facility
TU _c	chronic toxicity unit
TWAS	thickened waste activated sludge
U.S.	United States
UF/RO	ultrafiltration/reverse osmosis
USBR	United States Bureau of Reclamation
USFWS	U.S. Fish and Wildlife Service
USGVMWD	Upper San Gabriel Valley Municipal Water District
UV	ultraviolet
UWMP	Urban Water Management Plan
VOCs	volatile organic compounds
WAS	waste activated sludge
waters of the U.S.	waters of the United States
WDR	waste discharge requirement
WE	WRP Effluent Management
WNWRP	Whittier Narrows Water Reclamation Plant
WQOs	water quality objectives
WRD	Water Replenishment District of Southern California
WRP	water reclamation plant
WRR	water reclamation requirements
WSDM Plan	Water Surplus and Drought Management Plan
wtpd	wet tons per day
wtpy	wet tons per year
WVWD	Walnut Valley Water District
WWUR	Wet weather urban runoff

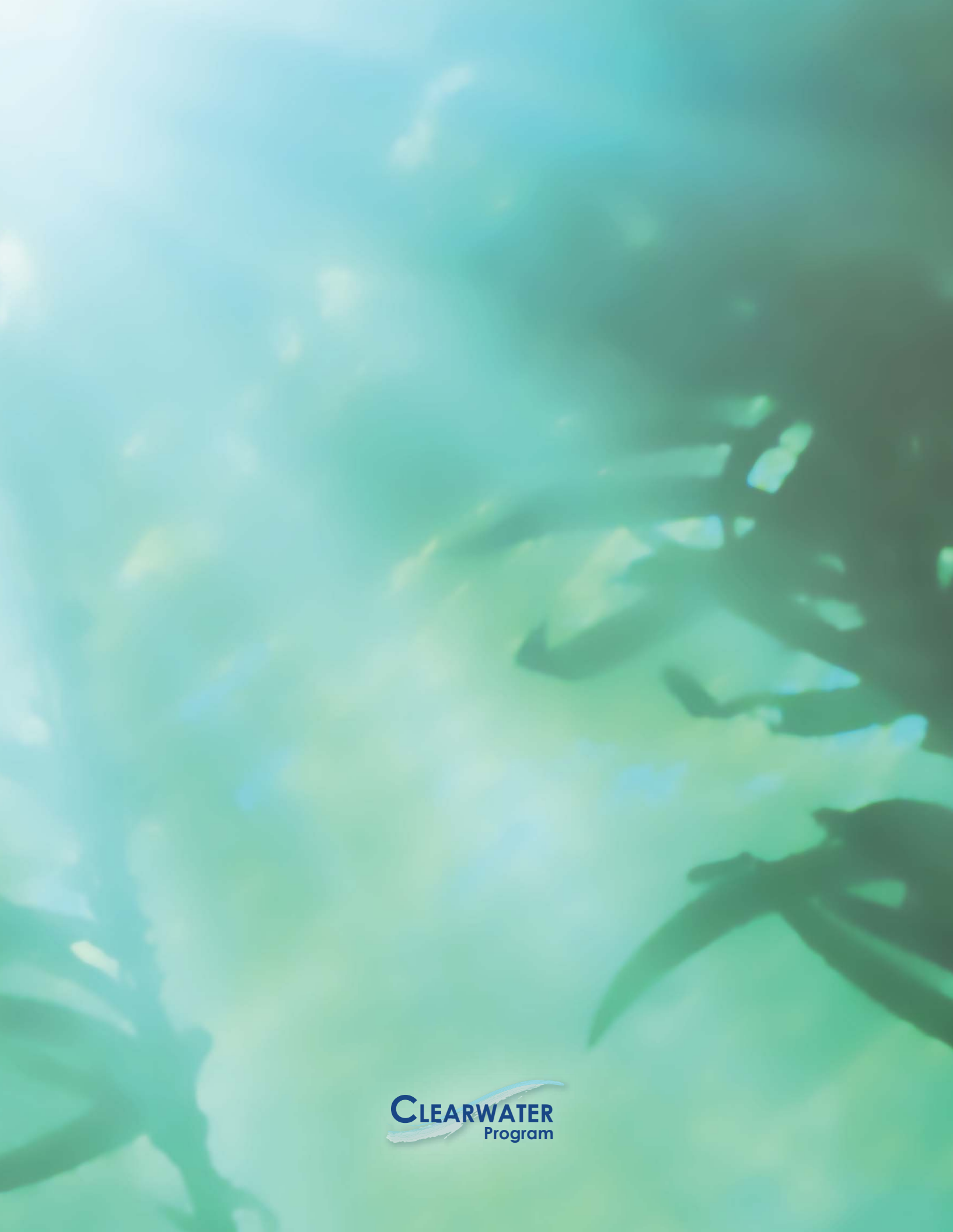

CLEARWATER
Program